



DEFENSE LOGISTICS AGENCY
HEADQUARTERS
8725 JOHN J. KINGMAN ROAD
FORT BELVOIR, VIRGINIA 22060-6221

IN REPLY
REFER TO

DLA J-627

September 9, 2010

MEMORANDUM FOR SUPPLY PROCESS REVIEW COMMITTEE (PRC) MEMBERS

SUBJECT: Approved Defense Logistics Management System (DLMS) Change (ADC) 376, Revise DLMS 846A Asset Reclassification and 947I Inventory Adjustment to Support Navy BRAC SS&D/IMSP (Supply) (Staffed as PDC 376A)

This change is approved for implementation. This change is required for an upcoming Defense Logistics Agency (DLA) and Navy system release to support Base Realignment and Closure (BRAC) Retail Supply, Storage and Distribution (SS&D) Inventory Management and Stock Positioning (IMSP).

DLA J-33 will provide procedures for the Navy BRAC SS&D/IMSP processes for inclusion in DOD 4000.25-M, DLMS, Volume 2. Depending on DLA's approach, the overall procedures will either be published under a separate ADC as a chapter to the DLMS manual, or specific procedures for each process may be published as addendums to the various Navy BRAC SS&D/IMSP ADCs.

Addressees may direct questions to the DLA Logistics Management Standards Office (formerly DLMSO) point of contact Ms. Mary Jane Johnson, email: Mary.Jane.Johnson@dla.mil. Others must contact their Component designated Supply PRC representative.

S. David Walker, Maj, USAF

for DONALD C. PIPP
Director
DLA Logistics Management
Standards Office

Attachment

cc:
DASD(SCI)
Joint Physical Inventory Working Group

ATTACHMENT TO ADC 376

Revise DLMS 846A Asset Reclassification Asset Reclassification and 947I Inventory Adjustment to Support Navy BRAC SS&D/IMSP (Supply) (Staffed as PDC 376A)

1. ORIGINATOR:

- a. **Service/Agency:** Defense Logistics Agency
- b. **Originator:** DLA J-331, 703-325-1924 (DSN 427)

2. FUNCTIONAL AREA: Primary: Supply/Logistics.

3. REFERENCES:

- a. DLMSO memorandum, July 2, 2010, subject: ADC 387, Defense Logistics Management System (DLMS) Enhancement: DLMS Supplement (DS) 846A Asset Reclassification Transaction and Associated Procedures, and Administrative Update to DS 947I Inventory Adjustment (staffed by PDC 408)
- b. DLMSO memorandum, April 8, 2010, subject: PDC 360A, Establishment of DLMS Supplement (DS) 832N, Catalog Data Support for Navy BRAC SS&D/IMSP, available at: <http://www.dla.mil/j-6/dlms/eLibrary/Changes/proposed.asp>
- c. DLMSO memorandum, July 1, 2010, subject: ADC 381, Procedures and Additional Data Content supporting Requisitions, Requisition Alerts, and Unit of Use Requirements under Navy BRAC SS&D/IMSP (Supply/Finance) (staffed by PDC 366A)
- d. DLMSO memorandum, April 20, 2010, subject: PDC 384, New DLMS Supplement (DS) 940S, Warehouse Service Request (for Materiel Protection/Re-Warehousing, Staging, and Picklist/Callout), New DS 943A, Warehouse Service Advice, and Associated Procedures under Navy BRAC SS&D/IMSP
- e. DLMSO memorandum, April 15, 2010, subject: PDC 405, Revise DLMS 947I Inventory Adjustment to Identify Loss due to Destructive Test in Support of Navy-DLA BRAC SS&D/IMSP
- f. AT&L Memorandum transmitted April 21, 2010, subject: Proposed Changes in support of Navy BRAC IMSP Spiral II. This memo documents ADUSD(L&RM)SCI direction provided to DLA and Navy authorizing immediate implementation of this DLMS change

3.REQUESTED CHANGE: Significant revisions subsequent to PDC 376A staffing are highlighted in yellow. Process Flows 10.2 and 11.1 are at Enclosure 2.

NOTE: Subsequent to release of PDC 376A, the BRAC IMSP Team added the **Customer Order Acceptance Record (COAR)** as a separate data element to most DLMS transactions which included Job Order (JO) number. The COAR is also embedded in the JO number. Addition of the COAR as a separate data element levies an 846A requirement to modify the COAR when modifying the JO, in order to keep the COAR embedded in the JO in sync with the separate COAR data element. .

PDC STAFFING NOTES are in gray highlight. Many required DLA-Navy response.

NOTE: The storage activity uses 846A Asset Reclassification Response transaction to confirm that 846A asset reclassification request to modify, remove, or assign protection, was accomplished, rather than a 947I Inventory Adjustment transaction. The table at Enclosure 1 summarizes when 846A is used as a request/response, and related action codes.

[947I Inventory Adjustment transaction for stock number change is used in response to an 846A asset reclassification request to convert an NSN to a unit of use Local Stock Number (LSN).]

a. Description of Change: In support of Base Realignment and Closure (BRAC) Retail Supply, Storage And Distribution (SS&D)/Inventory Management and Stock Positioning (IMSP), the Asset Reclassification transaction (DLMS Supplement (DS) 846A) will be used in support of three (3) independent processes to support Fleet Readiness Center (FRC) and Navy Shipyard (NSY) mission (refer to Enclosure 1 for process flows DLA provided which are associated with 846A):

- 1) The first process will allow EBS to request re-identification of assets to support less than unit of issue functionality¹.
- 2) The second process supports the requirement for NSY to assign protection to unprotected material in storage after receipt or to modify the protection document number, JO, Key Operation (KO) number, or COAR associated with material currently protected in storage after receipt.
- 3) The third process will allow EBS to protect asset(s) against a requisition alert sent from FRC or NSY site when it is determined unprotected stock is available for protection.

b. DS 846A is a DLMS enhancement in its entirety, with no MILSTRIP/MILSTRAP equivalent transaction. ADC 376 revises DS 846A, as revised by ADC 387 (reference 3a).

c. Background: As a result of the 2005 BRAC decision, retail supply, storage and distribution functions and associated infrastructure supporting the Navy industrial/maintenance sites will transfer to DLA. The Navy sites consist of 2 NSYs and 3 FRCs. The intent of the directive is to significantly improve combat effectiveness while reducing costs by developing a world-class, cost-effective supply chain focused on readiness; taking every opportunity to eliminate waste, reduce touches, reduce cost, and improve readiness. DLA will be the material provider for all standard and non-standard, DLA managed and non-DLA managed, consumable material required for fulfillment of Industrial Site Activity **unfunded requisition alerts** and **funded** requisitions. In accordance with the signed CON-OPS DLA has agreed to provide FRC and NSY sites with the ability to request material at less than the associated FLIS unit of issue. In addition, DLA has agreed to protect material at these sites. Material purchased by DLA in support of a NSY will be stored and protected by document number and Job Order (JO) Number combination. Materials purchased by DLA in support of a specific maintenance mission at an NSY or FRC site will be protected within EBS by using Purpose Code 'E' (DLA meaning for Purpose Code 'E' is 'Reserved for Maintenance').

d. Detailed Procedure:

1) Less than unit of issue request²:

a) The FRC or NSY site will submit a Requisition Alert or funded requisition (511R) to DLA for all consumable items required in support of specific maintenance jobs. These requests may be for DLA managed NSNs, other service managed NSNs, or Local Stock Numbers (LSN). When the request reflects the unit of use indicator, the request will also reflect a unit of use and quantity which is less than the FLIS unit of issue for a specific NSN. DLA will be responsible for purchasing, receipting, storing, protecting, inventory control, issuing and delivering of all consumable materials to support the request.

b) DLA will maintain inventory at the less than unit of issue under an EBS unique material type and material number. The material number will be treated as an LSN (Unit of Use) within

¹ PDC 360A and ADC 381 (references 3b and 3c respectively) address unit of use functionality.

² ADC 381 (reference 3c) documents procedures associated with requisitioning at the unit of use.

EBS and DSS. All subsequent transactions against this material will be recorded under this LSN within DLA systems. The LSN for Unit of Use will be derived from the NSN by modifying the first position of the NATO code to reflect a 'U', e.g., NSN = 5975011234567, LSN = 5975U11234567.

c) All transactions exiting NSY or FRC systems will reflect the Unit of Use indicator, NSN, and the unit of use as applicable. All subsequent associated transactions exiting DLA systems to NSY or FRC systems will reflect the LSN and NSN, Unit of Use indicator, Unit of Use as applicable.

d) In instances when the NSY or FRC unit of use requisition quantity equates to an equal FLIS unit of issue quantity, the unit of use indicator will be ignored by EBS and will not be perpetuated on subsequent transactions. EBS will provide Supply Status reflecting BG status code which indicates the NSN will be provided in the FLIS standard unit of issue. The adjusted quantity and price will be reflected on the supply status transaction.

e) When a requisition alert is for a unit of use, EBS will determine if an LSN has been previously established and if quantity is available.

f) There are different scenarios for DLA owned assets when a quantity needs to be re-identified or protected in support of the request from NSY or FRC site. The following are scenarios where EBS and DSS communicate to re-identify assets to a unit of use:

(1) When an LSN has been established and partial or full quantity is available at the Industrial Activity site (Unit of Use LSN material will not be stored at the DSS co-located depot, consequently any available unprotected quantity of the LSN will always be located at the IA site):³

(a) EBS will generate an 846A Asset Reclassification Request for assignment of protection (846A BIA02 Report Type Code TE with BIA06 Action Code "76-Assign") to DSS for the available quantity.

(b) DSS will process the 846A and assign requested protection. Reference to Document number and JO Number will be updated for NSY sites. **An 846A Asset Reclassification Response (BIA02 Report Type Code TD with BIA06 Action Code "24-On-Hold")** will be returned to EBS **confirming assignment of protection** when action is completed within DSS.

(c) Based on 846A Asset Reclassification Response confirming action complete, EBS will update protection; for NSY sites an internal table will be updated to reflect protected quantity against the Requisition Alert document number and JO number combination. At both NSY and FRC sites the quantity protected will be moved to Purpose Code 'E'.

(2) When an LSN has been established and no quantity is available but the NSN has available quantity at the co-located site:

(a) EBS will generate a 940S⁴ for re-warehousing and protection (Service Performed Code '7') to DSS for the available NSN quantity. Note 1: When the total quantity of the NSN being converted to an LSN is also to be protected, then normally the 940S will re-warehouse the NSN and protect the quantity being re-warehoused concurrently. That is, the protection document

³ This paragraph was revised from PDC 376A based on DLA-Navy IMSP Team discussion at the 5/25/2010 DSS CDR.

⁴ PDC 384 (reference 3d) creates new DS 940S Warehouse Service Request (for Materiel Protection/Re-Warehousing, Staging, and Picklist/Callout), and new DS 943A, Warehouse Service Advice, and associated procedures under Navy BRAC SS&D/IMSP

number and JO, etc., will be in the 940S. **Note 2:** When the total quantity of the NSN being converted to an LSN is not to be protected, then the 940S to re-warehouse the NSN will not contain the protection document number and JO.

(b) DSS will reply with a 943A, EBS will update an internal protection table.

(c) EBS will generate 846A Asset Reclassification Request to DSS requesting a specific quantity from the NSN be re-identified to the LSN (846A BIA02 Report Type Code TE with BIA06 Action Code 'CV-Convert'). **Note 1:** When the total quantity of the NSN being converted to an LSN was previously protected by the 940S, no protection assignment will be requested in the 846A. **Note 2:** When the quantity of the NSN being converted to an LSN was not previously protected by the 940S, the 846A converting the NSN to the LSN may concurrently protect some or all of the converted LSN quantity. When conversion and protection are concurrent, code '1' or '2' in the 846A LIN01 will be used in conjunction with 846A BIA02 Report Type Code TE with BIA06 Action Code 'CV-Convert'.

(d) DSS will confirm re-identification has been completed with a 947I Inventory Adjustment transaction with W1901 Quantity or Status Adjustment Reason (QSAR) Code 'AF-Stock Number Change' (Use to identify inventory adjustment increases and decreases due to stock number changes (MILSTRAP DI Code D8K /D9K functionality.) **Note:** When the 846A is used to concurrently convert and assign protection to material (whether the entire quantity or partial quantity), then an 846A Asset Reclassification Response transaction will ALSO be provided to confirm the protection assignment (846A BIA02 Report Type Code TD with BIA06 Action Code 24-On Hold.

STAFFING NOTE:

DSS will provide an 846A Asset Reclassification Response transaction to confirm assignment, modification, and removal of protection.

DSS will provide a 947I Inventory Adjustment Transaction (Stock Number Change) in response to 846A requests for NSN conversion to 'unit of use LSN'. An 846A will also be provided when all or part of the converted quantity is being protected.

(3) When an LSN has been established and neither the LSN or NSN have available quantities at the co-located site:

(a) EBS will take intervening actions to deliver the NSN associated with the LSN to the co-located site.

(b) EBS will generate a 940S WSR for re-warehousing and protection (Service Performed Code '7') to DSS for the available NSN quantity. **Note 1:** When the total quantity of the NSN being converted to an LSN is also to be protected, then normally the 940S will re-warehouse the NSN and protect the quantity being re-warehoused concurrently. That is, the protection document number and JO, etc., will be in the 940S. **Note 2:** When the total quantity of the NSN being converted to an LSN is not to be protected, then the 940S to re-warehouse the NSN will not contain the protection document number and JO.

(c) DSS will reply with a 943A WSA and EBS will update an internal protection table.

(d) EBS will generate 846A Asset Reclassification Request to DSS requesting specific quantity from the NSN to be re-identified (converted) to LSN (846A BIA02 Report Type Code TE with BIA06 Action Code 'CV-Convert'). **Note 1:** When the total quantity of the NSN

being converted to an LSN was previously protected by the 940S, no protection assignment will be requested in the 846A. **Note 2:** When the quantity of the NSN being converted to an LSN was not previously protected by the 940S, the 846A converting the NSN to the LSN may concurrently protect some or all of the converted LSN quantity. When conversion and protection are concurrent, code '1' or '2' in the 846A LIN01 will be used in conjunction with 846A BIA02 Report Type Code TE with BIA06 Action Code 'CV-Convert'.

(e) DSS will confirm re-identification has been completed with a 947I Inventory Adjustment with W1901 QSAR Code 'AF-Stock Number Change' (Use to identify inventory adjustment increases and decreases due to stock number changes (DI Code D8K /D9K functionality.)

Note: When the 846A is used to concurrently convert and assign protection to material, then an 846A Asset Reclassification Response will ALSO be provided to confirm the protection assignment (846A BIA02 Report Type Code TD with BIA06 Action Code 24-On Hold).

(4) When an LSN is not established:

(a) If there was not a previously established LSN for the less than unit of issue, EBS will establish a new LSN for the less than unit of use material. Catalog data is sent to DSS and Navy using 832N, Catalog Data Support.⁵

(b) Next actions will be determined based on assets availability for the NSN associated with the newly established LSN. Refer to steps (2) and (3) above.

2) When NSY is assigning protection to unprotected material or modifying Document number, JO, ~~or~~ Key Operation (KO) Number or COAR on protected stock: STAFFING NOTE: Capability to use 846A for assignment of initial protection (see paragraph 'g' on page 6) was added because it was not clear if Navy intent was to always assign initial protection to Navy owned inventory using 940S WSR transaction. If all Navy initial protection scenarios are covered by 940S, this capability can be removed from 846A. **IMSP Team Response to Staffing Note: Navy owned assets for which the 846A will be used to protect will be Mission Support Materiel (MSM) stock until balances have been depleted and only DLA inventory remains. All other Navy inventory should be protected upon receipt based upon the prepositioned materiel receipt (PMR) data, from there Navy will only use the 846A to modify or remove associated Document number, JO and KO from DSS records. (ASpry/DLA verified with JKill/Navy 5/17/2010)**

[Based on this response, capability will remain in the transaction since it seems to be needed in transition and could be a tool in Navy's tool box if they find post-transition reasons to use the 846A to assign initial protection. DLA IMSP Team representative concurred with leaving capability in transaction 5/25/2010].

a) Material will be on-hand recorded in DLA or Navy ownership at a co-located DSS IA worksite in support of a scheduled job to be performed at a shipyard. This material will be stored and protected against a specific document number and JO combination in both EBS and DSS (DLA Owned) or MAT and DSS (Navy Owned). The KO number is informational in DSS and EBS but is used in MAT as part of the protection methodology. **The COAR is also informational and facilitates DSS/IA site processes.** However, all 4 data elements can be assigned or modified by the 846A, when the material is in storage. For Rip Out material - modifications to the KO will be an overlay therefore all applicable KOs must be provided on the 846A. Additionally, the COAR may also be modified.

b) When material is Navy owned the exchange of all transactions below will be between MAT and DSS. When material is DLA owned the exchange of all transactions below will be among MAT, EBS and DSS.

⁵ PDC 360A (reference 3b) provides for DLMS 832N and associated procedures.

c) There are times when the engineers at the shipyards will need to re-identify the document number or JO or KO associated with a specific quantity to another in support of an urgent maintenance job. The quantity on the request maybe less than the original quantity on the Requisition Alert, but will never be greater than the original quantity. Additionally, when modifying the protection JO, the separate COAR may also need to be modified to match the new JO (the separately cited COAR and the COAR embedded in the JO must be kept in sync). Data will be entered into MAT requesting EBS to update the JO, KO and COAR associated with specific document number(s). MAT will submit to DLA EBS an 846A Asset Reclassification Request requesting that the protection be changed from one Document number and JO combination to another (846A BIA02 Report Type Code TE with BIA06 Action Code 'A6-Modified'). Upon receipt of the 846A request, EBS ensures there is sufficient quantity on-hand related to document number(s) and sends an 846A request to the associated DSS site. The 846A will reflect the current document number, JO and COAR combination as well as the new document number, JO and COAR as applicable. The document number, JO and COAR when being revised will have a 'from' and 'to' value. The KO is informational and will be an overlay; there will not be a 'from' and 'to' value for the KO.

d) DSS will receive and process the 846A Asst Reclassification Request to modify the relationship of the current Document number and JO/KO/COAR to another. When the action has been completed DSS will send an 846A Asset Reclassification Response to EBS. EBS will not modify the JO or KO or COAR associated with a specific document number until the 846A, is received back from DSS indicating that the action has been completed (846A Asset Reclassification Response transaction will be provided to confirm the protection modification (846A BIA02 Report Type Code TD with BIA06 Action Code 'S Re-record'). EBS will then change the JO/KO/COAR on the internal protection table and send the 846A, to the associated NSY site as confirmation that the requested protection modification has been completed.

e) When material is no longer required by the NSY site for its original intended purpose an 846A Asset Reclassification Request will be submitted by the NSY to EBS. When reference to all protection is to be removed, Action Code 'RA' will be reflected on the 846A request to remove all JO, KO, COAR and protection document number references currently protecting the material in EBS and DSS (846A BIA02 Report Type Code TE with BIA06 Action Code 'RA-Remove'). EBS will send the 846A transaction to DSS requesting the reference to JO/KO/COAR and document number be removed. When DSS completes the action, DSS will send an 846A Asset Reclassification Response to EBS confirming that the protection was removed (1/BIA02 Report Type Code TD with 1/BIA06 Action Code '13-Cleared'). EBS will remove document number and JO/KO/COAR reference from protection table, allowing assets to be available for global use. EBS will also send an 846A asset reclassification response to the associated NSY site as confirmation that the reclassification request has been completed. The 846A will cite 1/BIA02 code TD with 1/BIA06 Action Code '13-Cleared').

f) Navy may provide a 'default' JO/KO and COAR number for EBS to retain material under generic protection in anticipation of a new maintenance requirement. This information is provided to DSS for update and follows the procedure in paragraph d above.

g) For any unprotected Navy owned material in storage that is to be assigned protection for a new maintenance requirement, Navy may submit an 846A Asset Reclassification Request to DSS identifying the Document number and JO combination to be assigned for protection (846A BIA02 Report Type Code TE with BIA06 Action Code '76-Assign'). The KO number may also be provided, but will be informational only. Additionally, the separate COAR may need to be identified and match the assigned JO (the separately cited COAR and the COAR embedded in the JO must be in sync). The document number, JO, KO and COAR being assigned will have a 'to' value only. There will be no 'from' value. DSS will receive and process the 846A request to assign protection. When the action has been completed DSS will send an

846A Asset Reclassification Response to MAT confirming protection was assigned (846A BIA02 Report Type Code TD with Action Code 24-On Hold). **[See Staffing Note on page 5 at paragraph 2), which referenced this paragraph; as indicated at paragraph 2 capability will be retained in transaction.]**

h) In instances when the requisition alert document number and JO in the in the 846A request submitted to EBS by Navy do not match an entry in the EBS protection table, EBS will generate an 846A Asset Reclassification Denial Transaction (846A BIA02 Report Type Code TD with BIA06 Action Code DE-Deny) back to requesting site with an asset reclassification denial code, indicating no record of Document number and JO combination found in EBS, modification not accomplished. When EBS requests DSS modify the requisition alert document number and JO combination and the entries do not match DSS records, DSS will notify EBS that the modification was not accomplished using the 846A asset reclassification denial transaction with the same asset reclassification denial code. EBS will, in turn, generate the same 846A reflecting the Asset Reclassification Denial Code to the NSY site when request for change was not accomplished. When assets are Navy owned MAT will communicate the same request directly to DSS. This PDC proposes new Asset Reclassification Denial Code 'A' for this purpose. Code A: Asset Reclassification Request denied. No record of same Document number and Job Order (JO) combination found in the EBS protection table or DSS records. **STAFFING NOTE:** Paragraph modified to allow DSS to deny the modification request when the protection document number and JO do not match DSS records. Complements EBS rejection to Navy when data does not match EBS records.

i) If the Navy request submitted to EBS to modify the requisition alert document number and JO in EBS reflects a quantity greater than the protected quantity associated with the entry for the same document number and JO combination on the protection table, then EBS will generate an 846A Asset Reclassification Denial Transaction back to the requesting site with a new Asset Reclassification Denial Code, indicating the quantity on the request does not match DLA records. When the EBS request to DSS to modify the requisition alert document number and JO combination reflects a quantity greater than the protected quantity associated with the entry for the same document number and JO combination on DSS records, DSS will notify EBS using the 846A with the same asset reclassification denial code that the quantity on the request does not match DLA records. EBS will in-turn generate the same 846A reflecting the Asset Reclassification Denial Code to the NSY site when request for change was not accomplished. When assets are Navy owned MAT will communicate the same request directly to DSS. New Asset Reclassification Denial Code 'B' is assigned for this purpose: **Code B:** Asset Reclassification Request denied. Request quantity was greater than the protected quantity associated with the same document number and JO combination. **STAFFING NOTE:** Paragraph was modified in PDC to allow DSS to deny the modification request when the quantity is greater than quantity on record for doc number and JO. Complements EBS rejection to Navy when quantity does not match EBS records.

~~**j)** When EBS request DSS modify the requisition alert document number and JO combination against a specific material and quantity and DSS record indicates insufficient quantity is available against the same document number and JO combination, DSS will generate an 846A Asset Reclassification Denial Transaction back to the EBS with an Asset Reclassification Denial Code, indicating the quantity on the request does not match DSS records. EBS will generate the same 846A reflecting the Asset Reclassification Denial Code to the NSY site when request for change was not accomplished. Asset Reclassification Denial Code B in paragraph above would apply. **← A.Spry/DLA IMSP Team representative recommended deletion of paragraph j) per staffing note and responses below.**~~

PDC STAFFING NOTE: This denial condition seems to be the same as the one in the above paragraph i) where we added the sentence relative to DSS. The paragraph above addresses when the request quantity is greater than the protected quantity...that is essentially the same as this paragraph where the protected quantity is insufficient to cover the request quantity. At one time the IMSP team discussed that the modification from one document number and JO to another had to be for the total quantity protected by that document number/JO combination (No Partial). Perhaps this paragraph is intended to cover the condition when the modification

request quantity is less than the quantity protected by that document number/JO. If so, Navy or DLA must rewrite this paragraph to cover that condition. If partials are allowed, that is, the modification request quantity can be less than the protected quantity, then this paragraph and code would be unnecessary as the condition of insufficient quantity is covered in the previous paragraph.

A.Spry/DLA Response: The design team was thinking paragraph (i) describes a scenario when the quantity on the modification request is greater than currently assigned to the document number and JO, paragraph (j) was a scenario when modification was requested and DSS has insufficient quantity to modify. **We were trying to identify the difference when there significant differences in the protection between DSS and EBS for protection. Since these modifications would be systemic and not necessarily involve the physical pulling or counting of inventory we felt there was a need to know when quantity's associated with specific document number and JO were different between each system. This could defer any denials when material is called out on a funded requisition (A.Spry 5/17/2010).**

DLMSO RESPONSE: As long as we are describing systemic record to record quantity comparison, then paragraph (i) as written covers the condition when the 846A sent to DSS requests protection modification for a quantity greater than DSS has on record for the same document number and JO combination. That is, DSS has an insufficient quantity on their record to modify for that document number and JO combination. DLMSO recommends paragraph j) be deleted from the ADC.

3) When DLA is requesting protection of stock available at the Local site in support of a requisition alert:

a) EBS receives requisition alert from NSY or FRC site and determines unprotected stock is available at the co-located site.

b) EBS will flag the inventory to prevent other actions against quantity on requisition alert until confirmation of protection is received from DSS.

c) To protect material at an FRC site EBS will generate a 940S WSR for re-warehousing and protection (Service Performed Code '7') to DSS for the available quantity. DSS will reply with a 943A and EBS will internally move quantity to Purpose Code 'E'.

d) To protect material at an NSY site EBS will generate a 940S WSR for re-warehousing and protection (Service Performed Code '7') to DSS for the available quantity. **In addition to the protection document number the 940S will include the JO, KO and COAR. DSS will reply with a 943A and EBS will update the protection table and internally move quantity to Purpose Code 'E'. The 943A response from DSS will reflect the same document number, JO, KO and COAR on the initial request, thus allowing EBS to confirm protection correctly.**

PDC STAFFING NOTE FOR DLA: Earlier paragraphs in the PDC address protecting NSY materiel by JO number and document number, in addition to Purpose Code E. Does EBS expect DSS to return the document number and JO number for NSY materiel in the 943A WSA, for EBS to use to establish a cross reference to JO and document number to protect the NSY materiel? DLA must advise and update this paragraph as required in response to PDC. **A.Spry/DLA 5/17/2010 response/update provided for ADC at yellow highlighted sentence at the end of paragraph d) above.**

e) As an alternative to the 940S/943A exchange outlined above, DLA may employ the 846A to assign initial protection to unprotected DLA owned material when it is known re-warehousing is not required as the DLA owned unprotected stock is in storage at the IA worksite and EBS knows the location of the material, e.g., unprotected material associated with unit of use LSNs. Under this alternative, for any unprotected EBS owned material in storage that is to be assigned protection based on a requisition alert, EBS will submit an 846A Asset Reclassification Request to DSS identifying the Document number and JO number combination to be assigned for protection (846A BIA02 Report Type Code TE with BIA06 Action Code '76-Assign'). The KO number may also be provided, but will be informational only. **Additionally, the separate COAR may need to be identified**

and match the assigned JO (the separately cited COAR and the COAR embedded in the JO must be in sync). The document number, JO, KO and COAR being assigned will have a 'to' value only. There will be no 'from' value for the document number, JO, KO or COAR. DSS will receive and process the 846A request to assign protection and when the action has been completed DSS will send EBS an 846A Asset Reclassification Response to confirm the protection assignment (846A BIA02 Report Type Code TD with BIA06 Action Code 24-On Hold).

e. DLMS Procedures. DLA will submit DOD 4000.25-M, DLMS, procedures to address the Asset Reclassification process for BRAC SS&D IMSP, for inclusion in the DLMS manual, Vol 2.

f. Asset Reclassification Denial Code. Add a new LQ01 qualifier 'ARD-Asset Reclassification Denial' code to 846A as a local code. Upon approval of the ADC, DLMSO will submit a data maintenance request to ASC X12 for a new 1270 qualifier 'ARD'. Upon ASC X12 approval of the code for use in a higher version, 'ARD' would become a migration code for 846A:

Asset Reclassification Denial Code

New code for use with 846A Asset Reclassification Denial Transactions (DS 846A, 1/BIA02 Report Type Code TD)

CODE	EXPLANATION
<i>A</i>	<i>Asset Reclassification Request denied. No record of same Document number and Job Order (JO) combination found in the DLA Enterprise Business System (EBS) protection table or Distribution Standard System (DSS) records.</i>
<i>B</i>	<i>Asset Reclassification Request denied. Request quantity was greater than the protected quantity associated with the same document number and Job Order (JO) combination.</i>

g. Asset Reclassification Transaction use of Action Codes. Enclosure 1 provides a table identifying/summarizing 846A use of beginning segment Report Type Codes and Action Codes in support of BRAC IMSP SS&D.

h. DLMS Supplement (DS) 846A, Asset Reclassification, Change Table (includes administrative changes throughout to change the term 'BRAC SS&D/IMSP' to 'DLA industrial activity support agreement'):

Item #	Location	DS 846A Asset Reclassification Revision	Reason
1.	DLMS Intro Notes	<p><u>Add the following sentence at the end of DLMS Introductory note 1:</u></p> <p>Includes data to support Base Realignment and Closure (BRAC) Retail Supply, Storage and Distribution (SS&D)/Inventory Management and Stock Positioning (IMSP).</p>	<p>Administrative update. Acronyms used throughout DS are spelled out one time in this introductory note.</p> <p>This change is no longer required because the term "BRAC SS&D/IMSP" is being changed to 'DLA industrial activity support agreement' throughout DS.</p>

Item #	Location	DS 846A Asset Reclassification Revision	Reason
2.	DLMS Intro Notes	<u>Add ADC 376 to DLMS Introductory note 5:</u> - ADC 376, Revise DLMS 846A Asset Reclassification and 947I Inventory Adjustment to Support Navy BRAC SS&D/IMSP (Supply)	Identifies DLMS Changes included in the DLMS Supplement
3.	1/BIA01/020	<u>Add Qualifier ZZ with DLMS note:</u> ZZ Mutually Defined. DLMS Note: 1. Used by Navy industrial activities (IAs) to identify the Unit of Use Indicator. When included, the quantity and unit of measure values associated with this transaction are applicable to the unit of use, except when using the transaction to convert from an NSN to a unit of use LSN, (BIA02 code TE with BIA06 Action Code CV), then the MEA segment provides NSN-LSN conversion information. 2. Authorized for DLA industrial activity support agreement only. Refer to ADC 376 and ADC 381.	Supports Navy BRAC Spiral II requirements.
4.	1/BIA02/020	<u>Revise DLMS note for TD and TE:</u> TD Asset Reclassification Response DLMS Note: 1. Distribution depots/storage activities use for Asset Reclassification Denial Response Transactions. Must use with one of BIA06 Action Codes 13, 24, S, or DE. 2. For Asset Reclassification Response Denial transactions (Action Code DE), must also cite the Asset Reclassification Denial Code at 2/LQ01/376/ARD. TE Asset Reclassification Request DLMS Note: Owners use for Asset Reclassification Request Transactions. Must use in conjunction with appropriate BIA06 action code identifying the reason for the request (one of Action Codes: 23, 62, 76, 86, A6, CV, or RA); or, for Asset Reclassification Request Follow-up Transactions, must use in conjunction with BIA06 Action Code T 82.	Clarification supports use of 846A. Supports Navy BRAC Spiral II requirements.
5.	1/BIA02/020	<u>Revise DLMS notes for existing qualifiers AR and AX:</u> AR Asset Reclassification Extension Request DLMS Note: Distribution depots/storage activities use for Asset Reclassification Extension Request Transactions. Only used with assert reclassification request for supply condition code (SCC) change. AX Asset Reclassification Extension Response DLMS Note: Owners use for Asset Reclassification Extension Response Transactions. When disapproving an extension request, must use in conjunction with BIA06 Action Code 21. Only used with assert reclassification request for supply condition code (SCC) change.	Administrative update to note that codes only apply to asset reclassification request for SCC change. NOTE: No requirement for storage activity to request a time frame extension was identified for BRAC IMSP. As written, this capability only applies to SCC change with no impact on IMSP. Per A.Spry/DLA: Will not include in IMSP design. 5/25/2010

Item #	Location	DS 846A Asset Reclassification Revision	Reason
6.	1/BIA06/20	<p><u>Revise DLMS note</u></p> <p>82 Follow Up</p> <p>DLMS Note: Asset Reclassification Request Follow-up. Use to follow up on previously submitted Asset Reclassification Request. for supply condition code change. Use when no response (either an inventory adjustment transaction or an asset reclassification response denial) was received. Used with BIA02 code TE only.</p>	<p>PDC STAFFING NOTE: If DLA and Navy desire this follow-up capability for BRAC SS&D/IMSP, please comment to that effect. Follow-up capability is for use with SCC change, but could be expanded for all asset reclassification requests.</p> <p>ISMP design had not considered this, but would like to have this expanded to be used by IMSP as applicable.(A.Spry/DLA 5/17/2010)</p> <p>DLMSO Response: Revision expands use.</p>
7.	1/BIA06/20	<p><u>Add new action codes with DLMS notes as follows:</u></p> <p>13 Cleared</p> <p>DLMS Note: Asset Reclassification Response to confirm removal of protection. Use only in response to asset reclassification request to remove protection (request action code RA). Use with BIA02 code TD only. Authorized for DLA industrial activity support agreement only. Refer to ADC 376.</p> <p>24 On Hold</p> <p>DLMS Note: Asset Reclassification Response to confirm assignment of protection. Use only in response to asset reclassification request to assign protection (request action code 76); and in response to request to concurrently convert assets from NSN to a unit-of-use LSN and assign protection (request action code CV with LIN01 code 1 or 2). Use with BIA02 code TD only. Authorized for <i>DLA industrial activity support agreement</i> only. Refer to ADC 376.</p> <p>76 Assign</p> <p>DLMS NOTE: Asset Reclassification Request to allow DLA or Navy Shipyard (NSY) to protect asset(s). Use to assign protection JO-and document number as well as the informational KO and COAR, as required to protect materiel. <i>Authorized for DLA industrial activity support agreement only.</i> Used with BIA02 code TE only. Refer to ADC 376.</p> <p>S Re-record</p> <p>DLMS Note: Asset Reclassification Response to confirm modification of protection. Use only in response to asset reclassification request to modify protection (request action code A6). Use with BIA02 code TD only. Authorized for <i>DLA industrial activity support agreement</i> only. Refer to ADC 376.</p> <p style="text-align: center;">New action codes Continued on next page...</p>	<p>Supports Navy BRAC Spiral II requirements.</p> <p>The unit of use LSN concept is addressed in PDC 360A and ADC 381 (references 3c and 3d respectively).</p> <p>NOTE: Requirement to convert assets from an NSN to an LSN and ALSO protect a total or partial quantify was not addressed in the original PDC, but was discussed during IMSP meetings which DLMSO participated in. DLMSO confirmed requirement with DLA and made provisions for the requirement in PDC 376A.</p>

Item #	Location	DS 846A Asset Reclassification Revision	Reason
8.	1/BIA06/20	<p><u>BIA06 Action Codes continued from previous page:</u></p> <p>A6 MODIFIED DLMS NOTE: Asset reclassification request to modify the protection document number, and/or job order (JO) number, and/or informational key operation (KO) number for assets in storage. Also used to modify the informational COAR when the protection JO is being modified. The document number, JO and COAR, when being revised, will have from and to value. The KO will be an overlay. Used with BIA02 code TE only. Authorized for <i>DLA industrial activity support agreement only</i>. Refer to ADC 376.</p> <p>CV Convert DLMS NOTE: 1. Owner/manager Asset Reclassification Request to convert assets from an NSN to a unit of use local stock number (LSN). Used with BIA02 code TE only. See note 2 below if all or part of the quantity converted also needs protection. 2. When the total or partial quantity being converted to a unit of use LSN is also being protected by this same transaction, then use 2/LIN01/010 codes 1 (total converted quantity protected) or 2 (partial converted quantity to be protected), in conjunction with Action code CV. Partial quantity protection requires two iterations of LOOP ID QTY to convey two distinct quantities in the transaction for total quantity converted and partial quantity protected. 3. Authorized for <i>DLA industrial activity support agreement</i>. Refer to ADC 376.</p> <p>DE Deny DLMS Note: Asset Reclassification Response to deny an asset reclassification request transaction. Use with BIA02 code TD only. When using Action Code DE, must cite an asset reclassification denial code (2/LQ01/376/ARD.)</p> <p>RA Remove DLMS NOTE: Asset Reclassification Request to remove all protection. Remove all references to protection Job order number, Document Number and informational key operation number currently associated with the material in DLA EBS, DSS and Navy IA systems. Also used to remove the COAR when the protection JO is removed. Used with BIA02 code TE only. Authorized for <i>DLA industrial activity support agreement</i>. Refer to ADC 376.</p>	<p>Supports Navy BRAC Spiral II requirements.</p> <p>NOTE: IMSP Team added COAR to transactions which have JO Number.</p>

Item #	Location	DS 846A Asset Reclassification Revision	Reason
9.	1/N101/080	<p><u>Revise N101 data element DLMS Note 1 and add qualifier XM with DLMS note:</u></p> <p>DLMS Note 1: Use only one of codes SB, <i>XM</i>, or Z4.</p> <p>XM Maintenance Organization Used for Estimate DLMS Note: Use when applicable to identify the maintenance organization originating the requested action, e.g., Navy Shipyard or Fleet Readiness Center. Authorized for <i>DLA industrial activity support agreement</i>. Refer to ADC 376.</p>	<p>Supports Navy BRAC Spiral II requirements.</p> <p><u>PDC STAFFING NOTE:</u> Qualifier XM was not identified as a requirement in the PDC submitted, but DLMSO recommended adding. <u>RESPONSE:</u> IMSP design team concurs with suggestion.(A.Spry 5/17/2010)</p>
10.	2/LIN01/10	<p><u>Open LIN01 and add DLMS notes:</u></p> <p>DLMS Note: Use only with Asset Reclassification Request Transactions requesting that assets be converted from an NSN to a unit of use LSN (1/BIA02/020 code TE with BIA06 code CV), and only when the total or partial quantity converted to an LSN by this transaction is also to be protected by JO, or document number. Associated informational KO and COAR may also be provided as applicable. Then use LIN01 codes 1 (total converted quantity to be protected) or 2 (partial converted quantity to be protected). Partial quantity protection requires two quantities in the transaction. Authorized for DLA industrial activity support agreement only. Refer to ADC 376.</p> <p>1-The total quantity converted from an NSN to a unit of use LSN is also to be protected.</p> <p>2 – A partial quantity converted from an NSN to a unit of use LSN is also to be protected. A second iteration of LOOP ID QTY is required so that the partial quantity to be protected can be identified in addition to the total quantity being converted.</p>	<p>Supports Navy BRAC Spiral II requirements.</p>

Item #	Location	DS 846A Asset Reclassification Revision	Reason
11.	2/LIN02/10	<p><u>Revise data element level DLMS note 1, add new note 2, and renumber 2 as 3; and add new qualifier 'SW' with DLMS notes:</u></p> <p><u>Data element level DLMS notes:</u></p> <p>1. Use only one of codes A1, A2, A4, FB, FS, FT, MG, SW, YP or ZZ to identify the material. Must use National Stock Number (NSN) (code FS) when known, except when appropriate brand name subsistence items are identified by the Subsistence Identification Number, <i>or when industrial activity materiel is identified by a local stock number (LSN).</i></p> <p>2. For DLA industrial activity support agreement Asset Reclassification Requests used to reclassify materiel from an NSN to a unit of use LSN, cite the 'FROM' NSN in LIN02-03 and the 'TO' unit of use LSN in 2/LIN06-07.</p> <p>SW Stock Number DLMS Notes:</p> <p>1. Use to identify a local stock number (LSN), including the unit of use LSN assigned for NSN materiel issued at less than the unit of issue. For unit of use LSN, cite the cross reference NSN at LIN08-09.</p> <p>2. When reclassifying materiel from an NSN to a unit of use LSN (BIA06 code CV), must use LIN06-07 to cite the 'TO' unit of use LSN, and cite the 'FROM' NSN (code FS) in LIN02. Authorized for DLA industrial activity support agreement only. Refer to ADC 376.</p>	<p>Supports Navy BRAC Spiral II requirements.</p> <p>PDC STAFFING NOTE to NAVY and DLA: Is there a need for LSN in 846A Reclassification Requests not associated with reclassifying from an NSN to an LSN, e.g., to change JO for an LSN? If yes, qualifier for LSN is also needed at LIN02 as shown at left; however the 846A Data element requirements table in the original PDC submitted to DLMSO did not show this requirement.</p> <p>RESPONSE to STAFFING note: Yes there will be instances when an item identified with an LSN will have protection applied or modified by either EBS or MAT. (A.Spry/DLA)</p>
12.	2/LIN06-07/010	<p><u>Open LIN06-07 and add qualifier with DLMS notes to LIN06:</u></p> <p>SW Stock Number DLMS Note: Use to identify the unit of use LSN assigned for NSN materiel issued at less than the unit of issue when reclassifying materiel from an NSN to a unit of use LSN. The NSN is cited at LIN02-03. Authorized for DLA industrial activity support agreement only. Refer to ADC 376.</p>	<p>Supports Navy BRAC Spiral II requirements.</p>
13.	2/LIN08-09/010	<p><u>Open LIN08-09 and add qualifier with DLMS notes to LIN08:</u></p> <p>FS National Stock Number DLMS Note: Use to identify the cross reference NSN, when a unit of use LSN is identified in LIN02 (do not use with BIA06 action code CV-Convert). Authorized for DLA industrial activity support agreement only. Refer to ADC 376.</p>	<p>Supports Navy BRAC Spiral II requirements.</p>
14.	2/MEA/040	<p><u>Open 2/MEA/040 with DLMS note:</u></p> <p>DLMS Note: Use this segment when requesting that the storage activity reclassify materiel from an NSN to a unit of use LSN. Authorized for DLA industrial activity support agreement only. Refer to ADC 376.</p>	<p>Supports Navy BRAC Spiral II requirements.</p>
15.	2/MEA01/040	<p><u>Open MEA01 and add new qualifier CF with DLMS note.</u></p> <p>CF Conversion Factor DLMS Note:</p> <p>1. Use to identify the conversion factor to be used to convert FLIS NSN unit of issue quantity to LSN unit of use quantity</p> <p>2. Value is expressed as R5.4. The decimal point is passed within the transaction; leading and trailing zeros are not transmitted.</p>	<p>Supports Navy BRAC Spiral II requirements.</p> <p>DLA advised that value is expressed as R5.4. R5.4 meets Navy and DLA DSS requirements.</p>

Item #	Location	DS 846A Asset Reclassification Revision	Reason
16.	2/MEA03/040	<u>Open MEA03 with DLMS note:</u> DLMS Note: <i>Use to identify the factor by which the FLIS NSN unit of issue quantity must be multiplied to convert to the LSN unit of use quantity.</i>	Supports Navy BRAC Spiral II requirements.
17.	2/MEA04/040	<u>Open MEA04 and add DLMS notes at MEA04-01 and MEA04-04:</u> MEA04-01: <i>1. Use to identify the FLIS NSN unit of issue.</i> <i>2. DLMS users see the Unit of Issue and Purchase Unit Conversion Table for available codes.</i> MEA04-04: DLMS Notes: <i>1. Use to identify the LSN unit of use.</i> <i>2. DLMS users see the Unit of Issue and Purchase Unit Conversion Table for available codes.</i>	Supports Navy BRAC Spiral II requirements.
18.	2/DTM01/100	<u>Delete DLMS note 1:</u> 1. Use two occurrences of code 036, as needed, for the reclassification request transaction only. The first occurrence identifies the current categorization associated with the suspended or suspected material. The second occurrence identifies the categorization to which the suspended or suspected material should be reclassified	Administrative correction to DS. The DLMS note does not apply to this transaction.
19.	2/REF/140	<u>Add segment level DLMS notes:</u> DLMS notes: <i>1. Use multiple iterations of the REF segment to provide information as needed.</i> <i>2. Use multiple iterations of the REF segment to provide 'from' and 'to' data as required for Asset Reclassification Request transactions requesting modification of protection data (i.e. job order number, and associated informational COAR, and protection document number) in support of DLA industrial activity support agreement. Refer to ADC 376</i>	Supports Navy BRAC Spiral II requirements. NOTE: COAR added per IMSP Team decision during DSS Critical Design Review (CDR).
20.	2/REF01/140	<u>Modify DLMS note for existing qualifier TN:</u> TN Transaction Reference Number DLMS Note: <i>1. For asset reclassification associated with SCC changes, for suspected items in a non-suspended condition, cite the Inventory Control Point (ICP) assigned document number controlling the reclassification action.</i> <i>4. For asset reclassification associated with DLA industrial activity support agreement, this is the controlling document number for the Asset Reclassification Request/Response/Denial transactions. Refer to ADC 376.</i>	Supports Navy BRAC Spiral II requirements.

Item #	Location	DS 846A Asset Reclassification Revision	Reason
21	2/REF01/140	<p><u>Add the following qualifiers and DLMS notes:</u></p> <p>86 Operation Number DLMS Notes: Use to identify the informational key operation number. There is no 'FROM' or 'TO' key operation number. The key operation number is always an overlay. Authorized for <i>DLA industrial activity support agreement only</i>. Refer to ADC 376.</p> <p>9R Job Order Number DLMS Notes: 1. Use to identify the protection Job Order (JO) Number. 2. When modifying a JO Number, this is the 'TO' number, and the 'FROM' JO number uses qualifier 'JB'. 3. When assigning or removing protection, use to cite the JO. 4. When converting and materiel was previously protected, use to cite the protection JO. 5. Authorized for <i>DLA industrial activity support agreement only</i>. Refer to ADC 376.</p> <p>JB Job (Project) Number DLMS Notes: 1. Only use when modifying a JO number, this is the 'FROM' Number. The 'TO' JO number uses qualifier '9R'. 2. Authorized for <i>DLA industrial activity support agreement only</i>. Refer to ADC 376.</p> <p>CO Customer Order Number DLMS Notes: 1. Use to identify the informational Customer Order Acceptance Record (COAR) applicable to the Job Order Number. The separately cited COAR and the COAR embedded in the JO need to be kept in sync. Accordingly, when modifying the protection JO, the separate COAR must also be modified to match the associated JO. 2. When modifying a COAR to match the associated JO, this is the 'TO' number, and the 'FROM' COAR uses qualifier 'OW'. 3. When assigning or removing protection by JO, use to separately cite the COAR associated with the JO. 4. When converting and materiel was previously protected by JO, use to separately cite the COAR associated with the JO. 5. Authorized for <i>DLA industrial activity support agreement only</i>. Refer to ADC 376</p> <p>OW Service Order Number DLMS Notes: 1. Only use when modifying a COAR, this is the 'FROM' COAR. The 'TO' COAR uses qualifier 'CO'. 2. Authorized for <i>DLA industrial activity support agreement only</i>. Refer to ADC 376.</p>	<p>Supports Navy BRAC Spiral II requirements.</p> <p>PDC STAFFING NOTE on KO: DLMSO understanding is that the Key operation number is always an overlay and there is no 'from' and 'to' required. Required Navy-DLA response.</p> <p>FINAL KO RESPONSE: A.Spry/DLA, Correct the KO will be overlay not a 'from' and 'to' data element. 5/25/2010.</p> <p>PRELIMINARY KO RESPONSE: There will be instances for NSY owned material when the KO is modified when it is applied to MCT process. ASpry verified with JKill 5/17/2010</p> <p>DLMSO COMMENT: While this may be true, do not understand the need for a 'from' and 'to' KO. That is the KO is informational to DSS. While they will have it on their record associated with the document number, they will not protect by it. Therefore, they will not need to match the 'from' KO on the 846A to their DSS records before they change/overlay it. DSS only needs to match on the 'from' Document number and JO before they can modify the protection. So 'from' and 'to' is not needed for the KO.]</p> <p>A.Spry/DLA comment 8/19/2010: Since the data element will be on additional paper work generated by DSS for NSY personnel when material is issued it is important to the NSY sites that this be updated</p> <p>DLMSO RESPONSE 8/26/10: DLMSO understanding is this is accomplished by overlay rather than 'from and to' values.</p> <p>COAR added per IMSP Team decision during DSS CDR. COAR is informational, however A.Spry confirmed that 'FROM' and 'TO' COAR values are needed for 846A so that COAR on record does not become out-of-synch with JO when JO is modified.</p>

Item #	Location	DS 846A Asset Reclassification Revision	Reason
22.	2/REF01/140 <i>continued</i>	<p>18 Plan Number DLMS Notes: 1. Use to identify the protection document number (document number under which the materiel is protected.) This includes requisition alert document number and Navy funded document number. Use qualifier 'TN' for the controlling document number for the Asset Reclassification Request/Response transactions. 2. When modifying the protection document number, this is the 'TO' number, and the 'FROM' number uses qualifier 'T9'. 3. When assigning or removing protection, use to cite the protection document number. 4. When converting and materiel was previously protected, use to cite the protection document number. 5. Authorized for <i>DLA industrial activity support agreement only</i>. Refer to ADC 376.</p> <p>T9 Documentation Affected Number DLMS Notes: 1. Only use when modifying the protection document number (document number under which materiel is protected, includes requisition alert document number and Navy funded document number). This is the 'FROM' number. The 'TO' number uses qualifier '18'. 2. Authorized for <i>DLA industrial activity support agreement only</i>. Refer to ADC 376.</p>	<p>STAFFING NOTE: DLMSO understanding is that 846A will be used to modify the document number (doc#) under which the materiel is protected, and that this could be a 'requisition alert doc#' or a 'Navy funded doc#'. If that understanding is accurate, DLMSO recommends a generic qualifier for the protection doc# under which the materiel is protected. RESPONSE: Yes is can be either funded or requisition alert document number depending upon material owner. (A.Spry/DLA)</p>
23.	2/REF04-01/ 140	<p><u>Revise DLMS note for existing qualifier W8-Suffix Code:</u> DLMS Note: Use in to identify the suffix code associated with REF01 code 18, F8, or T9, or <i>TN</i>.</p>	Supports Navy BRAC Spiral II requirements.
24.	2/PER/150	<p><u>Open optional PER segment with the standard DLMS notes.</u></p>	Administrative update to provide for optional use of PER segment to identify points of contact, consistent with other DLMS Supplements.

Item #	Location	DS 846A Asset Reclassification Revision	Reason
25	2/QTY/ 320	<p><u>Revise current DLMS segment level note and add new note 2:</u></p> <p>DLMS Note: 1. Use multiple iterations of the 2/QTY/320 loop to stratify quantity on hand by material classification. Use only in material Asset Reclassification Request transactions (1/BIA02/20 code TE). 2. When an asset reclassification request transaction is requesting conversion of an NSN to a unit of use LSN, and concurrently requesting assignment of protection to a partial quantity of the quantity converted (BIA02 code TE with BIA06 Action Code CV in conjunction with LIN01 code 2), then two iterations of 2/QTY/320 loop must be used to convey two distinct quantities in the transaction for total quantity to be converted and partial quantity to be protected. Supports <i>DLA industrial activity support agreement</i>. Refer to ADC 376.</p>	<p>Administrative update at DLMS Note 1.</p> <p>DLMS Note 2 supports Navy BRAC Spiral II requirements.</p>
26	2/QTY01/ 320	<p><u>Revise DLMS note for existing qualifier QH</u></p> <p>QH Quantity on Hold DLMS Note: Use only for <i>supply condition code (SCC)</i> reclassification request transactions (<i>BIA02 code TE with BIA06 Action Code 23, 62, or 86</i>). Use to identify the quantity for which <i>SCC</i> reclassification is requested; <i>otherwise do not use</i>.</p>	<p>Administrative update to document that ‘quantity on hold’ related to SCC asset reclassification request. This PDC expands 846A use beyond the original DLMS enhancement use. ‘Quantity on hold’ was associated with suspended SCCs.</p>

Item #	Location	DS 846A Asset Reclassification Revision	Reason
27.	2/QTY01/320	<p><u>Add qualifiers V3 and XT and with DLMS note:</u></p> <p>V3 Transfer Quantity DLMS Note: 1. Use only with asset reclassification requests transactions which request an NSN be converted to a unit of use LSN (BIA02 code TE with BIA06 Action Code CV-Convert); otherwise do not use. 2. When LIN01 is not used, or LIN01 cites code1, only this quantity field is used in the transaction. It represents the quantity to be converted without a request for protection assignment (no LIN01 code); or the quantity to be converted with a request for protection assignment when the entire conversion quantity is to be protected (LIN01 code 1). When protecting the entire quantity or the converted quantity was previously protected, the protection information will be cited in 2/REF/140. When there is no protection assignment request associated with the conversion (LIN01 not used and quantity was not previously protected), then no protection information (JO, protection document number, informational KO or COAR) will be cited in 2/REF/140., 3. When LIN01 code 2 is used (indicating that only a PARTIAL quantity converted from an NSN to unit of use LSN is to be protected, then a second iteration of the QTY segment must be used to cite a second quantity (code XT) to identify the partial quantity to be protected. 4. Authorized for use under DLA industrial activity support agreement only. Refer to ADC 376.</p> <p>XT Protected Quantity DLMS Note: 1. Use with asset reclassification requests to assign protection (BIA02 code TE with BIA06 Action Code76-Assign); and with requests to assign protection to a partial quantity when concurrently requesting conversion from an NSN to a unit of use LSN ((BIA02 code TE with BIA06 Action Code CV-Convert in conjunction with LIN01 code 2); otherwise do not use. When concurrently requesting protection for a partial quantity being converted to a unit of use LSN, then 2 iterations of the QTY segment must be used. One iteration will cite code V3 for the total quantity converted, and one iteration will cite code XT for the partial quantity to be protected. When requesting protection assignment to a partial quantity, the applicable protection data (JO, protection document number, informational KO/COAR) cited in 2/REF/140 applies only to this partial protection quantity. 2. Authorized for DLA industrial activity support agreement only. Refer to ADC 376.</p>	<p>Supports Navy BRAC Spiral II requirements to use 846A Asset Reclassification Request transaction to convert a quantity from an NSN to a unit of use LSN, and to also protect only a portion of the quantity converted, in this same reclassification request transaction.</p>

Item #	Location	DS 846A Asset Reclassification Revision	Reason
28.	2/LQ01/ 376	<p><u>Revise DLMS note for existing qualifier ARD:</u></p> <p>ARD Asset Reclassification Denial Code DLMS Note: Storage activities must use with Asset Reclassification Response Denial Transactions (BIA02 code TD <i>in conjunction with BIA06 Action Coode DE</i>) to identify the reason for the denial. <i>At this time a local code 'ARD' is established for use in 846A, version 4010. A data maintenance action will be submitted for establishment of 'ARD-Asset Reclassification Denial Code' in a future version.</i></p>	
29.	2/N101/ 450	<p><u>Revise N101 data element DLMS Note 1 and add qualifier XM with DLMS note:</u></p> <p>DLMS Note 1: Use only one of codes SB, XM, or Z4.</p> <p>XM Maintenance Organization Used for Estimate DLMS Note: <i>Use when applicable to identify the maintenance organization e.g., Navy Shipyard or Fleet Readiness Center. Authorized for DLA industrial activity support agreement. Refer to ADC 376.</i></p>	<p>Supports Navy BRAC Spiral II requirements.</p> <p>PDC STAFFING NOTE: This was not identified as a requirement in original PDC submitted, but DLMSO recommends adding for 846A sent to NSY or FRC.</p> <p>RESPONSE: IMSP concurs with this suggestion.</p>

i. DS 947I Inventory Adjustment Change Table:

Item #	Location Version 4030	DS 947I Inventory Adjustment (Table Locations address 947I version 4030, corresponding changes made to version 4010)	Reason
1.	DLMS Intro Notes	<p><u>Add the following sentence at the end of DLMS Introductory note 1:</u></p> <p>Includes data to support Base Realignment and Closure (BRAC) Retail Supply, Storage and Distribution (SS&D)/Inventory Management and Stock Positioning (IMSP).</p>	<p>Administrative update. Acronyms used throughout DS are spelled out one time in this introductory note. This change is no longer required because the term "BRAC SS&D/IMSP" is being changed to 'DLA industrial activity support agreement' throughout DS.</p>
2.	DLMS Intro Notes	<p><u>Add ADC 376 to DLMS Introductory note 6:</u></p> <p>- ADC 376, Revise DLMS 846A Asset Reclassification and 947I Inventory Adjustment to Support Navy BRAC SS&D/IMSP (Supply)</p>	<p>Identifies DLMS Changes included in the DLMS Supplement</p>
3.	2/W1504/ 0200	<p><u>Add Qualifier ZZ with DLMS note:</u></p> <p>ZZ Mutually Defined.</p> <p>DLMS Note: 1. <i>Used to identify the Unit of Use Indicator. When included, the quantity and unit of measure values associated with this transaction are applicable to the unit of use.</i> 2. <i>Authorized DLMS enhancement for DLA industrial activity support agreement only. Refer to ADC 376 and ADC 381.</i></p>	<p>Supports Navy BRAC Spiral II requirements. Code to distinguish unit of use requirements.</p>

Item #	Location Version 4030	DS 947I Inventory Adjustment (Table Locations address 947I version 4030, corresponding changes made to version 4010)	Reason
4.	2/W1902/ 0200	<u>Add DLMS Note 3 to credit/debit quantity:</u> DLMS Note: 3. For inventory adjustments resulting from converting an NSN to a unit-of-use local stock number (LSN), under DLA industrial activity support agreement, the loss transaction will cite the NSN loss quantity in W1902 and FLIS unit of issue in W1903. The gain transaction will cite LSN gain quantity in W1902 and the LSN unit of use in W1903. Refer to ADC 376.	Supports Navy BRAC Spiral II requirements.
5.	2/W1903/ 0200	<u>Add DLMS Note 2 to unit or basis for measurement code:</u> DLMS Note: 2. For inventory adjustments resulting from converting an NSN to a unit-of-use local stock number (LSN) under DLA industrial activity support agreement, the loss transaction will cite the FLIS unit of issue in W1903. The gain transaction will cite the LSN unit of use in W1903. Refer to ADC 376.	Supports Navy BRAC Spiral II requirements.
6.	2/W1905/ 0200	<u>Revise data element level DLMS note1 and add new qualifiers ‘SW’ and ‘ZR’ with DLMS notes:</u> <u>Data element level DLMS notes:</u> 1. Use only one of codes A1, A2, A3, A4, FB, FS, MG, NN, SW , YP, ZR or ZZ to identify the materiel. shipped . Must use National Stock Number (NSN) when known, except, when appropriate, brand name subsistence items are identified by the subsistence identification number or when industrial activity materiel is identified by Local Stock number (LSN) or Materiel Control Tracking (MCT) tag number. An exception is also authorized for CAV where materiel may be identified by the National Item Identification Number (NIIN) when the Federal Supply Code (FSC) is not available. SW Stock Number DLMS Notes: 1. Use to identify a local stock number (LSN), including the unit of use LSN assigned for NSN materiel issued at less than the unit of issue except as noted below for conversion from NSN to unit of use LSN. 2. For inventory adjustments resulting from converting an NSN to a unit of use LSN, the NSN is cited at W1905 for the inventory adjustment loss transaction, and the unit of use LSN is cited at 2/N901/0400 W1905-06 for the inventory adjustment gain transaction. Authorized for DLA industrial activity support agreement only. Refer to ADC 376. ZR Service Control Identification DLMS Note: Use to identify Materiel Control Tracking (MCT) tag number. The MCT tag number is an authorized DLMS enhancement under DLA industrial activity support agreement. Refer to ADC 376.	Supports Navy BRAC Spiral II requirements. ADC 376 change for qualifier ‘SW’ corrects mapping provided by PDC 376A. Change is based on DLA comment that for testing, DLA DSS is using the W1906 for the gain LSN in the 947I for D8K functionality; in addition, review of current DAAS map for 947I supports use of W1905-06 for the inventory adjustment gain materiel identification (whether NSN, LSN, etc). [PDC 376A incorrectly reflected mapping to N901 (see rows 8 and 10 of this change table).] MCT tag number was previously added to 947I by PDC 366A. It is being incorporated in ADC 376 for consistency with changes made to 846A by ADC 376.

Item #	Location Version 4030	DS 947I Inventory Adjustment (Table Locations address 947I version 4030, corresponding changes made to version 4010)	Reason
7.	2/W1907/ 0200	<p><u>Add the following qualifier and DLMS notes:</u></p> <p>FS National Stock Number DLMS Note: 1. Use to identify the NSN. 2. The NSN is provided as a cross-reference when unit of use indicator is included and the unit of use Local Stock Number (LSN) is identified as the primary materiel identification in W1905. Authorized DLMS enhancement under DLA industrial activity support agreement.</p> <p>RV Repair Tag Number DLMS Note: Use with Code ZR to identify the MCT tag number suffix.</p>	<p>Supports Navy BRAC Spiral II requirements.</p> <p>When a unit of use LSN is identified in W1905, the cross-reference NSN will be included here (previously identified in PDC 366A).</p> <p>NOTE: Per IMSP Team decision, MCT Tag Suffix is no longer a separate data element.</p>
8.	2/N9/ 0400	<p><u>Revise segment level DLMS note 2 and add new note 4:</u></p> <p>Segment level DLMS Notes: 2. May use a second repetition to identify the new material identification when the inventory adjustment results from a stock change Number (W1901 Quantity or Status Adjustment Reason Code AF). DLMS enhancement. See DLMS introductory note 4a. For Inventory Adjustment Gain transactions associated with stock number change (W1901 Quantity or Status Adjustment Reason Code AF (MILSTRAP D8K functionality)), the gain NSN (or other materiel identification) is mapped to W1905-06. Accordingly, the intent of DLMS note 2 for single inventory adjustment (stock number change is unclear and under review.</p> <p>4. May use additional repetitions to identify protection information as needed to support DLA industrial activity support agreement (e.g., protection document number, Job Order (JO) number, key operation (KO) number). Refer to ADC 376.</p>	<p>Removing PDC 376A admin update to DLMS Note 2 and providing revised administrative update. For Inventory Adjustment Gain transactions associated with stock number change (W1901 QSAR Code AF), the gain NSN or LSN, etc, is mapped to W1905-06. The intent of existing DLMS note 2 is unclear at this time, and business rules for use would need to be developed in a PDC. Hence use is being identified as a DLMS enhancement.</p> <p>Supports Navy BRAC Spiral II requirements.</p>
9.	2/N901/ 0400	<p><u>Revise data ID level DLMS note 2:</u></p> <p><u>DLMS Note:</u> 2. To identify new material identification when the inventory adjustment results from a stock number change, use only one of codes 1I, ABV, EQ, FQ, MF, NS, S6, or XD. DLMS enhancement. See DLMS introductory DLMS note 4a. For Inventory Adjustment Gain transactions associated with stock number change (W1901 Quantity or Status Adjustment Reason Code AF (MILSTRAP D8K functionality)), the gain NSN (or other materiel identification) is mapped to W1905-06. Accordingly, the intent for use of N901 with single inventory adjustment (stock number change) is unclear and under review.</p>	<p>Administrative DLMS update.</p>

Item #	Location Version 4030	DS 947I Inventory Adjustment (Table Locations address 947I version 4030, corresponding changes made to version 4010)	Reason
10.	2/N901/ 0400	<p><u>Add or revise qualifiers with DLMS notes:</u></p> <p><u>Revise use for existing qualifier S6:</u> S6 Stock Number DLMS Note: <i>Local stock number (LSN). DLMS enhancement. See introductory DLMS note 4a.</i></p> <p><u>Add qualifiers with DLMS notes:</u></p> <p>86 Operation Number DLMS Notes: <i>Use to identify the key operation number. Authorized for DLA industrial activity support agreement only.</i></p> <p>9R Job Order Number DLMS Notes: <i>Use to identify the Job Order (JO) Number. Authorized for DLA industrial activity support agreement only.</i></p> <p>CO Customer Order Number DLMS Note: <i>Use to identify the Customer Order Acceptance Record (COAR) applicable to the Job Order Number. Authorized for DLA industrial activity support agreement only.</i></p> <p>ABV Book Number DLMS Note: <i>Use to identify the publication stock number. DLMS enhancement; see introductory DLMS note 4a.</i></p> <p>18 Plan Number DLMS Notes: 1. Use to identify the protection document number (document under which the materiel is protected). This includes requisition alert document number and Navy funded document number. Use qualifier 'TN' for the controlling document number for the Inventory Adjustment transactions. 2. Authorized for DLA industrial activity support agreement only.</p> <p><u>Revise DLMS note for existing qualifier TN</u> TN Transaction Reference Number DLMS Note: Must use to identify the <i>document</i> number for each transaction, except (for DLA only) when the contract number is provided in 2/CS/0500.</p>	<p>Supports Navy BRAC Spiral II requirements.</p> <p><u>DLMS DATA NOTE:</u> 'S6-Stock Number, previously used in this segment for 'Publication Number', is being reassigned for use in this segment as Local Stock Number (LSN) for consistency with other DS. 'Publication number' is a DLMS enhancement not yet implemented, and will be reassigned for 947I 2/N901/0400 to 'ABV-Book Number'. For BRAC SS&D/IMSP, the gain LSN maps to the W1905-06, not N901 [see row 6 of this change table.]</p> <p>COAR added per IMSP Team decision during DSS Critical Design Review (CDR).</p> <p><u>STAFFING NOTE:</u> 846A will be used to modify/assign the document number under which the materiel is protected, and that this could be a 'requisition alert doc#' or a 'Navy funded doc#'. Accordingly a generic qualifier is being used for the 'protection document number'.</p> <p>Administrative DLMS update to identify that the 'transaction reference number' is an inventory adjustment 'document number' (consistent with changes made to other DS).</p>

Item #	Location Version 4030	DS 947I Inventory Adjustment (Table Locations address 947I version 4030, corresponding changes made to version 4010)	Reason
11.	2/N901/ 0400	<u>Add standard DLMS enhancement note to the following qualifiers:</u> II DOD Identification Code (DODIC) DLMS note: Use to identify ammunition items. <i>DLMS enhancement. See introductory DLMS note 4a.</i> EQ Equipment Number DLMS note: Use to identify plant equipment. <i>DLMS enhancement. See introductory DLMS note 4a.</i> FQ Form Number DLMS note: Use to identify the form stock number. <i>DLMS enhancement. See introductory DLMS note 4a.</i>	Administrative DLMS update to identify data as DLMS enhancements consistent with other DS. Changes are not related to BRAC Spiral II but are administrative updates being made while 947I is open for revision under this ADC.
12.	2/N907- 01/0400	<u>Revise DLMS note for existing qualifier W8-Suffix Code:</u> W8 Suffix DLMS Note: Use to identify the suffix code associated with N901 code 18 or TN.	Supports Navy BRAC Spiral II requirements.
13.	2/N101/ 1100	<u>Add qualifier XM with DLMS note:</u> XM Maintenance Organization Used for Estimate DLMS Note: Use when applicable to identify the maintenance organization, e.g., Navy Shipyard or Fleet Readiness Center. Authorized for DLA industrial activity support agreement only. Refer to ADC 376.	Supports Navy BRAC Spiral II requirements.

j. Data Tables for 846A and 947I submitted by DLA for PDC are at Enclosure 3.

4. REASON FOR CHANGE: As a result of BRAC 2005 SS&D EBS will be purchasing, storing and issuing all consumable items in support of the Navy Industrial sites changes will ensure the same or better functionality exist after the implementation of BRAC 2005 as before.

5. ADVANTAGES AND DISADVANTAGES:

a. **Advantages:** Enterprise Business System (EBS), Material Access Technology (MAT), Material Resource Planning (MRP) II and Distribution Storage System (DSS), will be able to comply with DLMS standards for the BRAC IMSP Spiral 2 process

b. **Disadvantages:** None identified.

6. ESTIMATED TIME LINE/IMPLEMENTATION TARGET: DLA and Navy planned implementation date is **December 2010**

7. IMPACT:

a. **Publications:**

1) Requires update to DS 846I and 947I.

2) Requires update to DOD 4000.25-M, DLMS, to add procedures for the BRAC SS&D/IMSP process described by this ADC. DLA J-33 to provide procedures for the DLMS manual, Vol 2.

b. Automated Information Systems (AIS): DLA Enterprise Business System (EBS), DLA Distribution Standard System (DSS), Navy Material Access Technology (MAT), and Navy Material Resource Planning (MRP) II systems.

c. DAAS Mapping. Update DAAS maps to allow new data to pass any applicable edits. There is no mapping requirement between MILS and DS 846A since there are no corresponding MILSTRAP or MILSTRIP transactions.

d. DLMS Data:

1) New Data Element: Identifies requirement for a new ASC X12 data element ID 1270 qualifier for Asset Reclassification Denial Code. [Code requirement was also identified in ADC 387].

2) Adds existing ASC X12 BIA06 data element ID 306 Action code values to 846A. Action codes added to 846A by ADC 376 with short explanation (these codes may be used in other DLMS transactions for other purposes)

846A Action Code	Short Explanation
A6 Modified	Asset reclassification request to modify the document number, and/or job order (JO) number, and/or key operation (KO) number for assets in storage.
CV Convert	Owner/manager Asset Reclassification Request to change assets from an NSN to a unit of use local stock number (LSN).
DE Deny	Storage activity uses to provide an asset reclassification denial response.
RA Remove	Asset Reclassification Request to remove all protection. Remove all references to Job order number, key operation number, and Document Number currently protecting the material
S Re-Record	Storage activity uses with an asset reclassification response to confirm protection was modified
13 Cleared	Storage activity uses with an asset reclassification response to confirm protection was removed
24 On-Hold	Storage activity uses with an asset reclassification response to confirm protection was assigned
76 Assign	Asset Reclassification Request to request protection of assets (to assign JO, KO, protection document number, as required to protect materiel).

3) Open 846A LIN01 to identify “code” values.

4) Adds the following to 846A, all of which are also added to other DS by other BRAC SS&D IMSP PDCs: Maintenance organization, e.g., Navy Shipyard or Fleet Readiness Center; job order number; key operation number; local stock number; COAR.

5) Adds the following to 947I, all of which are also added to other DS by other BRAC SS&D IMSP PDCs: Maintenance organization, e.g., Navy Shipyard or Fleet Readiness Center; job order number; key operation number; local stock number; COAR.

6) Adds 'protection document number' and suffix to 846A and 947I. This is the document under which the materiel is protected in storage (e.g., materiel could be protected under requisition alert document number; Navy funded document number).

8. COMMENTS TO PDC 376A:

	ORGANIZATION	PDC 376A RESPONSE/COMMENT	DLMSO Disposition
1	NAVY (NAVSUP)	Navy concurs with PDC 376A as written and submits no additional changes or amendments.	Noted.
2	MARINE CORPS	Concurs as written.	Noted.
3	ARMY	Concurs.	Noted.
4	USTRANSCOM	Abstains.	Noted.
5	DLA	Concurs.	Noted.
6	DLA DDC J6N (Jim Weiner)	Paragraph C1D on page 2 it should read "In instances when the NSY or FRC unit of <i>USE</i> requisition" PDC has 'Unit of <i>ISSUE</i> '	Correction made.
7	DLA J6U (Russ Taylor/ Dave Griffin)	For testing we are using the W1906 for the gain LSN in the 947I D8K.	Revised DS 947I Change Table to map the gain LSN to W1906 rather than N901. See 947I Change Table, rows 6, 8, and 10.
8	DSS Critical Design Review (CDR) Action Item:	A. Item Data: 1. Further guidance needed on conversion factor, e.g., length, how to apply to unit price of UOU LSN, divide? 832N/846A wording impact (PDCs)? Also, EBS/Navy need a process for creating UOU LSNs for Navy-owned materiel.	<u>A.Spry/DLA IMSP Team Lead response: 6/23/2010:</u> Both the NSY and FRC use multiplication and fractions. The decimal on the conversion factor needs to be at least 4 positions to satisfy FRC, NSY and DSS. DLMSO added Note to 846A to specify newly identified conversion factor requirement for 4 position decimal.
9	IMSP Team	Deleted MCT Tag Suffix as a separate data elements.	Update made to 947I.
10	IMSP Team	Added COAR to transactions which had JO Number	COAR added to 846A and 947I by this change.

	ORGANIZATION	PDC 376A RESPONSE/COMMENT	DLMSO Disposition
11	DLMSO	Requested DLA IMSP Team Lead confirm whether COAR 'FROM' and 'TO' values were needed for 846A. The COAR is imbedded in the JO number. Without from/to values, the COAR on record could become out-of-synch with the JO Number on record, as the JO number is modified using 846A.	<u>A.Spry/DLA IMSP Team Lead</u> confirmed COAR 'FROM' and 'TO' values are needed in 846A. DLMSO Updated DS 846A to provide 'From' and 'To' COAR values.
12	DLMSO DLA IMSP Team Lead (A. Spry)	DLMSO: 846A has capability to follow up on a previously submitted Asset Reclassification Request transaction, when no response was received. If DLA and Navy desire this follow-up capability for BRAC SS&D/IMSP, comment to that effect in response to the PDC. Follow-up capability is currently for use with SCC change, but could be expanded for all asset reclassification requests.	ISMP design had not considered this, but would like to have this expanded to be used by IMSP as applicable. (A.Spry/DLA 5/17/2010) <u>DLMSO Response:</u> Revised DLMS note to expand use. See 846A Change Table, row 6.
13	DLA IMSP Team Lead (A. Spry)	Page 5, subparagraph 2c) added new second sentence: <i>“The quantity on the request maybe less than the original quantity on the Requisition Alert, but will never be greater than the original quantity.”</i>	Change incorporated in ADC.
14	DLA IMSP Team Lead (A. Spry)	8/27/2010 DLMSO provided DLA lead with final draft of ADC 376 with latest revisions highlighted, for IMSP Team review/comment. 8/31/2010 DLA Response (A.Spry): DLA IMSP team concurs with the changes.	Noted and ADC finalized.

Enclosures

ENCLOSURE 1 to ADC 376
Table identifying 846A Action Code Usage in Support of BRAC IMSP

846A associated with NSN to unit of use LSN conversion, and sometimes protection assignment:				
Asset Reclassification <u>REQUEST</u> Transaction (BIA02 Code TE)			Asset Reclassification <u>RESPONSE</u> Transaction (BIA02 Code TD)	
BRAC SS&D/IMSP Related BIA06 Action Code	Brief explanation		BRAC SS&D/IMSP Related BIA06 Action Code	Brief explanation
CV Convert	Request to change assets from an NSN to unit if use LSN when LIN01 is NOT USED	response is 947I for stock number change	Not applicable. No 846A Response when LIN01 not used	
	When used with LIN01 code 1 : concurrently assign protection for ENTIRE converted quantity.	response is 947I for stock number change PLUS	24 On-Hold	confirms assignment of protection (prepared for entire converted quantity)
	When used with LIN01 code 2 : concurrently assign protection for PARTIAL converted quantity.	Response is 947I for stock number change PLUS	24 On-Hold	confirms assignment of protection (prepared for partial converted quantity)
846A associated with protection assignment, modification, removal, but <u>not</u> associated with NSN to LSN conversion:				
Asset Reclassification <u>REQUEST</u> Transaction (BIA02 Code TE)			Asset Reclassification <u>RESPONSE</u> Transaction (BIA02 Code TD)	
BRAC SS&D/IMSP Related BIA06 Action Code	Brief explanation		BRAC SS&D/IMSP Related BIA06 Action Code	Brief explanation
76 Assign	Assign Protection		24 On-Hold	confirms assignment of protection
A6 Modify	Modify protection		S Re-record	confirms modification of protection
RA Remove	Remove Protection		13 Cleared	confirms removal of protection
			Asset Reclassification Response Denial	
			DE Deny	Denial of Asset Reclassification Request. (Must be used with LQ01 Asset Reclassification Denial Codes. Codes A, B have been defined.)

846A also has capability which was NOT identified as required for BRAC SS&D IMSP:
 --Storage activity request for an extension on the asset reclassification request timeframe (BIA02 code AR)
 --ICP to response to the request for extension (BIA02code AX).

ENCLOSURE 2 TO ADC 376 PROCESS FLOWS



10.2: Change/cancellation of JON/KO after receipt – Final

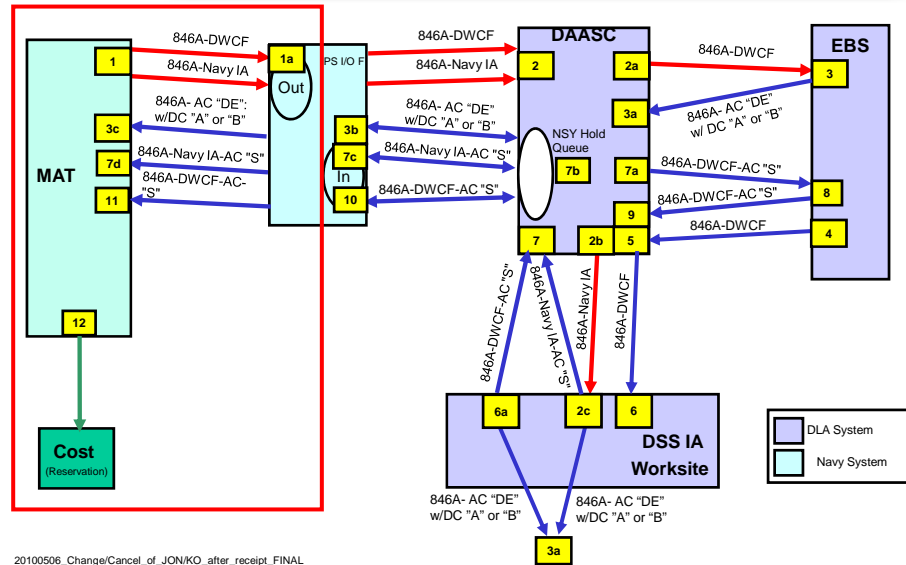

Note: 846A Transactions (request for asset re-identification) as represented in this flow and worksheet apply to modifications of JO/KO (may include document number or suffix code) and applies to DWCF and Navy Owned material after receipt.

NSY user requests a change or cancellation to JO/KO associated with a requisition alert after receipt of DLA owned material or for Navy owned material. MAT creates appropriate cost transactions and an appropriate 846A is sent to the out queue of PSI/OF. -> 1a

1a. The NSY's PSI/OF pushes 846A(s) to DAASC. -> 2

2. DAASC receives and validates 846A(s) -> 2a (DWCF), 2b (Navy IA)

2a. DAASC routes 846A (DWCF) to EBS ->3

2b. DAASC validates and routes 846A to DSS IA worksite (Navy owned) ->2c

2c. DSS IA Worksite receives and validates the 846A for Navy IA owned material.

- If unsuccessful, DSS creates/sends a 846A (Navy IA owned) with Action Code "DE" and a Denial Code of "A" (can't find match for document #) or "B" (quantity discrepancy) to DAASC -> 3a

- If successful, DSS updates the relationship between material and document number (Navy IA Owned) and creates/sends a 846A with an Action Code "S" to DAASC. ->7

3. EBS will receive the Navy IA's 846A for DWCF material and validates that the document number and quantity exist in EBS.

- If unsuccessful, EBS creates a 846A with Action Code "DE" and a Denial Code of "A" or "B" and sends it to DAASC. -> 3a

- If successful, EBS initiates 846A processing. -> 4

3a. DAASC receives, validates and places the unsuccessful 846A with Action Code "DE" and Denial Code "A" or "B" in the NSY Hold Queue ->3b

3b. The NSY's PSI/OF pulls the 846A(s) with Action Code "DE" and Denial Code "A" or "B" from the DAASC NSY Hold Queue and pushes these transactions to MAT for processing. ->3c

3c. MAT processes the 846A (s) with Action Code "DE" and Denial Code "A" or "B". -> END

4. EBS flags the material protection table for document number in 846A for DWCF material and sends 846A(s) to DAASC. -> 5
5. DAASC will receive, validate and route the 846A for DWCF material to the DSS IA Worksite.->6
6. DSS IA Worksite receives the 846A (DWCF Owned material) for validation and processing. -> 6a
- 6a. DSS IA Worksite validates the 846A for DWCF Owned material.
 - If unsuccessful, DSS creates/sends the 846A (DWCF owned) with Action Code "DE" and a Denial Code of "A" or "B" to DAASC -> 3a
 - If successful, DSS updates the relationship between material and document number (Navy IA Owned) and creates/sends the 846A with an Action Code "S" confirmation to DAASC. ->7
7. DAASC receives and validates the 846A with an Action Code "S" for Navy IA owned and DWCF material. -> 7a,7b
- 7a. DAASC routes 846A with an Action Code "S" (DLA owned) confirmation to EBS -> 8
- 7b. DAASC places the 846A with an Action Code "S" (Navy owned) confirmation in the NSY Hold queue -> 7c
- 7c. The NSY's PSI/OF pulls the 846A(s) with an Action Code "S" (Navy owned) confirmation and pushes these transactions to MAT for processing. -> 7d
- 7d. MAT updates the JO/KO JML with the 846A with an Action Code "S" confirmation. -> 12
8. EBS will receive and process 846A with an Action Code "S" (DLA owned) confirmation and passes image of the 846A with an Action Code "S" confirmation to DAASC. ->9
9. DAASC receives and validates the 846A with an Action Code "S" (DLA owned) confirmation and places the transaction in the NSY Hold Queue. -> 10
10. The NSY's PSI/OF pulls the 846A(s) with Action Code "S" (DLA and Navy owned) confirmations and pushes these transactions to MAT for update. -> 11
11. MAT updates the JO/KO JML with the 846A with an Action Code "S" confirmation. -> 12
12. MAT's existing interface to Cost will update the reservation table in Cost for the future A0_ issue document. -> END



11.1: Less Than Unit of Issue – FINAL

DLA's BRAC SS&D IT solution must be capable of moving material to the Navy Industrial Sites at its wholesale unit of issue but subsequently, issue and bill on a non-standard unit of issue (unit of use) to reflect actual Job/Work Order requirements

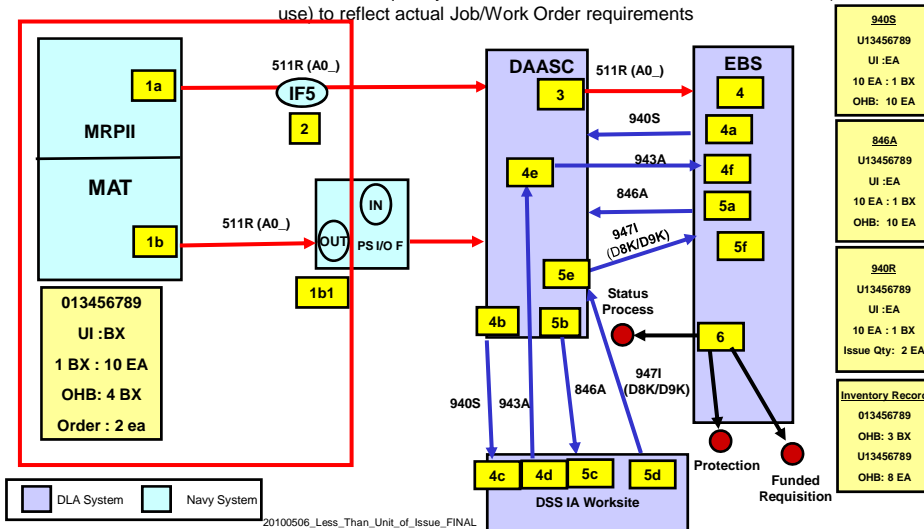

- 1a. FRC User requests Unit of Use material which triggers IF5. ->2
- 1b. NSY user requests Unit of Use material which triggers MAT to create a 511R (A0_) -> 1b1
- 1b1. PS I/O F receives in the out folder and sends the 511R (A0_) to DAASC -> 3
2. IF5 creates 511R (A0_) and sends to DAASC. ->3
3. DAASC receives, validates and routes the 511R to EBS.
4. EBS receives the unit of use 511R (Requisition Alert /Issue Order) with appropriate DLMS qualifier.
 - Issue Order - If sufficient quantity is on hand at the UOU (e.g., Mission Support Material (MSM) stock)), the request becomes back ordered, ->6.
 - Requisition Alert- If sufficient quantity is on hand at the UOU (e.g., Mission Support Material (MSM) stock)), the quantity becomes protected, ->6.
 - When EBS recognizes the UOU on the 511R (does not match the FLIS UOI) a request for Re-identification of Assets (846A) will be utilized to re-identify quantity to UOU. ->4a
- 4a. EBS sends requests for rewarehousing and re-classification to protect assets (940S AC#7) to DAASC. ->4b, 5a
- 4b. DAASC receives and passes the 940S to DSS IA worksite. ->4c
- 4c. DSS IA Worksite receives and processes the 940S ->4d
- 4d. DSS IA Worksite rewarehouses stock from DD and generates 943a to DAASC -> 4e
- 4e. DAASC receives and passes the 943a to EBS. -> 4f
- 4f. EBS receives and processes the 943a. -> 5a
- 5a. EBS sends requests for re-identification of assets (846A) to DAASC. ->5b
- 5b. DAASC receives and passes the 846A to DSS IA worksite. ->5c
- 5c. DSS IA Worksite receives and processes the 846A ->5d
- 5d. DSS IA Worksite re-identifies stock and generates 947I, D8K/D9K to DAASC -> 5e
- 5e. DAASC receives and passes the 947I, D8K/D9K to EBS. -> 5f
- 5f. EBS receives and processes the 947I, D8K/D9K. -> 6 and 7
6. EBS creates an outbound AE_ 870S and passes it to DAASC. -> END (Status process, Funded Requisition or Requisition Alert Process)

ENCLOSURE 3 TO ADC 376

846A and 947I Data Tables submitted by DLA for PDC (DLMSO changes/notes are highlighted or red text)

Table A. 846A Data

#	DS Location	DS 846A Data Content	Description	Field Length
1.	REF01 2/REF01/ 140/JB	Original Job Order Number <i>FROM Job Order Number</i>	Code used at Naval Ship yards identifying a particular package of work. <i>From Job Order number when changing.</i>	10
2.		Original Key Operation Number	Key Operation number reflected on the original Requisition Alert transaction. STAFFING NOTE: WHY are 'original' and 'modified' KO needed? IMSP discussions indicated KO was always an overlay and 'from' to' values were not needed. <i>KO provided at 2/REF01/140/86.</i> Since the data element will be printed on additional paper work generated by DSS for NSY personnel when material is issued it is important to the NSY sites that this be updated and visible to them. A.Spry 8/19/2010. <i>DLMSO Agrees it will be updated. Our understanding, as documented in PDC 376A, is this is accomplished by overlay rather than 'from' and 'to' values. 8/26/2010.</i>	3
3.	2/REF01/140/T9	Original Requisition Alert Document Number <i>FROM protection Document Number (doc# under which materiel is protected)</i>	Document number reflected on the original pre-requisitioning requirements signal. Original Demand Signal Document number, suffix code and JO/KO will be key data elements to releasing issues at Naval Shipyards. <i>DLMSO provided for a generic document number data element in 846A which represents the doc no under which the materiel is protected (includes both requisition alert document number and Navy funded document number)</i> Request Navy-DLA refer to the staffing note in the DS 846A Change Table at 2/REF01/140 codes '18' and 'T9'. IMSP is okay with Mapping the changes of Document Number using these qualifiers A. Spry 8/19/2010	14
4.	2/REF04/ 140/W8	Original Requisition Alert Suffix Code <i>(see notes above)</i>	Suffix code reflected on the original pre-requisitioning requirements signal. Original Demand Signal Document number, suffix code and JO/KO will be key data elements to releasing issues at Naval Shipyards. <i>Suffix code is available for use in 846A with applicable document numbers as appropriate.</i>	1
5.	2/REF01/ 140/9R	Modified Job Operation Number <i>Job Order Number. 'TO' JO number when revising.</i>	New value for Job Order when Navy closes one availability and roles material to another.	10
6.	REF01	Modified Key Operation Number	New value for the key operation number which will overlay the original key operation number. DLMSO comment: 'original' and 'modified' KO not needed. IMSP discussions indicated KO was always an overlay and 'from' to' values were not needed. <i>KO provided at 2/REF01/140/86.</i>	3

#	DS Location	DS 846A Data Content	Description	Field Length
7.	2/REF01/140/18	Modified Requisition Alert Document Number <i>Protection Document Number. When modifying, this is the TO number.</i>	New value for the Requisition Alert Document Number when Navy closes one availability and roles material to another. Document number reflected on the original requisition alert transaction. STAFFING NOTE: Request Navy-DLA refer to the staffing note in the Enclosure 2 DS 846A Change Table at 2/REF01/140 codes '18' and 'T9'. <i>Document number provided in 846A which represents the 'protection' document number (includes both requisition alert document number and Navy funded document no.)</i>	14
8.	LIN02/FS	National Stock Number	NSN from which the quantity is to be re-identified or which is related to the JO, document number combination for a modification	13
9.	LIN06/SW	Unit of Use Local Stock Number	Unit of Use LSN to which quantity is to be re-identified to	13
10.	2/MEA04-01/040	FLIS unit of issue	Current unit of issue recorded against the original stock number prior to re-identification	2
11.	2/MEA04-04/040	LSN unit <i>use</i>	Unit of use to which the quantity is to be re-identified	2
12.	2/QTY/320/V3	QTY re-identified from	Specific quantity which is to be re-identified from the NSN to the unit of use LSN	7
13.	2/MEA01/040	Unit of Use conversion factor	Conversion factor to be used to convert FLIS unit of issue quantity to LSN unit of use quantity e.g. for a BX of 10 each with a conversion factor of 0.1, the result would be a qty of 10 each at the LSN	5
14.	1/BIA01/ZZ	Unit of Issue Indicator	Code/Flag indicating transaction is to reidentify assets to less than unit of issue. E.g., for 10	1
15.	2/LQ01/376/ARD	Management Code <i>Asset Reclassification Denial Code (See Asset Reclassification Denial Codes A, B in PDC for definitions)</i>	* Indicates quantity on Asset re-identification is greater than quantity associated in either DSS or EBS against document reflected on transaction. * Indicates DSS or EBS has no record of Document and JO combination reflected in the asset re-identification request.	
16.	1/BIA06/020	Action Code <i>Added 8 new BIA06 Action Codes to support BRAC SS&D/IMSP.</i>	* modification document number or job order for specific quantity currently protected under another document number and job order combination *removed all protection for quantity against specific document number and JO combination.	

Table B. 947I Data.

#	DS Location	DS 947I Data Content	Description	Field Length
1.	2/N901/0400/9R	Original Job Order Number <i>Job Order Number Same as row 5</i>	Job Order reflected on the original Requisition Alert transaction. Applies to NSY sites only. <i>947I is used as response to request to convert NSN to unit of use LSN. It is not used as response to modify protection (846A response will be provided.) Accordingly there are no from/to (original/modified) protection JO values.</i>	10

#	DS Location	DS 947I Data Content	Description	Field Length
2.	KO provided at 2/REF01/140/86.	Original Key Operation Number DLMSO STAFFING NOTE: 'original' and 'modified' KO not needed. IMSP discussions indicated KO was always an overlay; no 'from' to' needed.	Key Operation Number. The logical division of a Job Order which may be scheduled to be performed without significant interruption, and which can be closed out to further charges upon completion. Applies to NSY sites only Alpha/Numeric Field	3
3.	2/N901/0400/18	Original Requisition Alert Document Number <i>Protection document number Same as row 7</i>	Document number reflected on the original requisition alert request. Applies to NSY sites only. <i>947I is used as response to request to convert NSN to unit of use LSN. It is not used as response to modify protection (846A response will be provided.) Accordingly there are no from/to (original/modified) protection doc number values.</i>	14
4.	2/N907-01/0400	Original Requisition Alert Suffix Code <i>Suffix code is available for use in 947I with applicable doct numbers as appropriate.</i>	Suffix code reflected on the original pre-requisitioning requirements signal. Applies to NSY sites only.	1
5.	2/N901/0400/9R	Modified Job Operation Number <i>Job Order Number Same as row 1</i>	New value for the Job Order number which will change the Job Order currently recorded in EBS/DSS. <i>947I is used as response to request to convert NSN to unit of use LSN. It is not used as response to modify protection (846A response will be provided.) Accordingly there are no from/to (original/modified) protection JO values.</i>	10
6.		Modified Key Operation Number	New value for the key operation number which will overlay the original key operation number. DLMSO NOTE: 'original' and 'modified' KO not needed. IMSP discussions indicated KO was always an overlay and 'from' to' values were not needed. KO provided at 2/REF01/140/86.	3
7.	2/N901/0400/18	Modified Requisition Alert Document Number <i>Protection Document number Same as row 3</i>	New Value for Requisition Alert Document Number when Navy closes one availability and roles material to another. Document number reflected on the original requisition alert transaction. <i>947I is used as response to request to convert NSN to unit of use LSN. It is not used as response to modify protection (846A response will be provided.) Accordingly there are no from/to (original/modified) protection doc number values.</i>	14
8.	2/W1905/0200/FS	NSN	NSN from which the quantity is to be re-identified or which is related to the JO, doc number combination for a modification	13
9.	2/N901/0400/S6	Unit of Use Local Stock Number	Unit of Use LSN to which quantity is to be re-identified to	13
10.	2/W1903/0200	FLIS unit of issue	Current unit of issue recorded against the original stock number prior to re-identification	2
11.	2/W1903/0200	LSN unit of <i>use</i>	Unit of issue to which the quantity is to be re-identified	2
12.	2/W1902/0200	QTY re-identified from	Specific quantity which is to be re-identified from the NSN to the unit of use LSN	7
13.	2/W1504/0200	Unit of Issue Indicator	Code/Flag indicating transaction is to reidentify assets to less than unit of issue. E.g., for 10	1