



DEFENSE LOGISTICS AGENCY
HEADQUARTERS
8725 JOHN J. KINGMAN ROAD
FORT BELVOIR, VIRGINIA 22060-6221

June 15, 2015

MEMORANDUM FOR SUPPLY PROCESS REVIEW COMMITTEE (PRC) MEMBERS

SUBJECT: Approved Defense Logistics Management Standards (DLMS) Change (ADC) 1132, Implementation of Mass/Universal Cancellation Procedures under the DLMS and Administrative Realignment of Procedures in DLM 4000.25, Volume 2 and DLM 4000.25-1

The attached change to DLM 4000.25, Defense Logistics Management Standards, and DLM 4000.25-1, Military Standard Requisition and Issue Procedures (MILSTRIP), is approved. Delayed implementation is authorized. Components are required to provide target implementation dates to DLMSO.

Addressees may direct questions to Ms. Ellen Hilert, DOD MILSTRIP Administrator, 703-767-0676 or DSN 427-0676, e-mail: ellen.hilert@dla.mil, or Ms. Heidi Daverede, DOD MILSTRIP Alternate, 703-767-5111; DSN 427-5111, e-mail: heidi.daverede@dla.mil. Others may contact their Component designated Supply PRC representative available at: <https://www2.dla.mil/j-6/dlms0/CertAccess/SvcPointsPOC/allpoc.asp>.

A handwritten signature in black ink, appearing to read "Donald C. Pipp", is positioned above the typed name.

DONALD C. PIPP
Director
Defense Logistics Management
Standards Office

Attachment
As stated

cc:
ODASD (SCI)
OSD DPAP (PDI)

Attachment to ADC 1132

Implementation of Mass/Universal Cancellation Procedures under the DLMS and Administrative Realignment of Procedures in DLM 4000.25, Volume 2 and DLM 4000.25-1

1. ORIGINATING SERVICE/AGENCY AND POC INFORMATION: Defense Logistics Management Standards Office (DLMSO), Heidi Daverede, 703-767-5111

2. FUNCTIONAL AREA:

a. **Primary/Secondary Functional Area:** Supply

b. **Primary/Secondary Functional Process:** Mass and Universal Cancellation Procedures

3. REFERENCES:

a. [DLM 4000.25](#), Defense Logistics Management Standards, Volume 2

b. [DLM 4000.25-1](#), Military Standard Requisitioning and Issue Procedures (MILSTRIP)

4. APPROVED CHANGE(S): Changes made subsequent to the staffing of the PDC are highlighted in GREEN.

a. **Brief Overview of Change:**

(1) This change proposes the implementation of a fully systemic solution for processing mass and universal cancellations and the associated DLMS enhancements.

(2) This change establishes a new Chapter 27 in DLM 4000.25, Volume 2 that consolidates procedures, both DLMS enhanced and legacy, associated with mass and universal cancellation procedures into one location. This change administratively aligns the new Volume 2, Chapter 27 with its companion chapter in DLM 4000.25-1 MILSTRIP Chapter 8.

b. **Background:**

(1) This is one of several DLMS changes to update DLM 4000.25, Volume 2 requisitioning and issue procedures to align with the procedures in DLM 4000.25-1. Once all the DLM 4000.25-1 chapters are fully aligned into Volume 2, then DLM 4000.25-1 will be canceled. At that time, DLM 4000.25, Volume 2 will serve as the single guidance for requisitioning and issue procedures business rules, data standards, and transaction formats.

(2) DLM 4000.25-1, Chapter 8 outlines procedures associated with Mass and Universal Cancellations using a combination of offline message formats and legacy MILSTRIP 80 record position formats. DLM 4000.25, Volume 2, Chapter 4 outlines DLMS enhanced procedures for Requisitioning and Status Reporting, to include Mass and Universal Cancellations, using DLMS formats (X12 Electronic Data Interchange (EDI) and eXtensible Markup Language (XML)).

(3) The mass and universal cancellation procedures in Volume 2 have not been formally coordinated with the Supply Process Review Committee, nor have the associated DLMS enhancements, resulting in little to no automation of an offline process managed through message traffic/emails/faxes.

c. Approved Change in Detail:

(1) *Initiation of Mass or Universal Requisition Cancellation*

(a) Requests for mass or universal cancellation of requisitions must be initiated by the DOD Component headquarters, or by an authorized command element. In lieu of DLMSO maintaining a list of Component representatives authorized to send and receive mass/universal requisition cancellation requests, the Component's requisitioning system will ensure that only authorized users initiate the mass/universal cancellation requests, thereby allowing the resulting transactions to process systemically. Pending update of Component supply systems to implement this DLMS change, if there are any questions regarding the authenticity of a mass/universal cancellation, contact either the Component Supply PRC Representative or the customer support representative for the source of supply (SoS). Component Supply PRC Representatives are identified on the DLMSO Website at <https://www2.dla.mil/j-6/dlms0/CertAccess/SvcPointsPOC/allpoc.asp>.

(b) Due to the requirement to ensure that the request is only initiated by authorized personnel, mass or universal cancellation of requisitions must not be initiated through use of DOD EMALL, or its replacement system FEDMALL.

(c) The DLMS 869C is authorized for implementation, in lieu of the message format identified in DLM 4000.25, Volume 2, Appendix 6.23.

Staffing Note #1: Components are requested to identify if automated support for mass or universal cancellation (sending or receiving) has been developed, based upon DLMS implementation design or implementation.

Navy Response: Navy does not currently have automated support for mass or universal cancellation. Navy also does not have any sort of controls or points of contact that are formally appointed to support this process.

Air Force Response: ILS-S (AF Retail Supply) has a capability to create and send requisition cancellations for base closure and mission change processing.

DLA Response: DLA only automated the Mass/Universal Cancellation logic when a DODAAC has been deleted. We still operate manually based on requests via approved messages.

Marine Corps Response: Currently, no Marine Corps systems have developed automated processing of universal mass cancellations.

Army Response: Mass or universal cancellation (sending or receiving) has not been fully developed in GCSS-Army.

DLMSO Disposition: When automating the mass/universal cancellation process, Components must comply with the procedures and transaction standards outlined in this DLMS change.

(d) Delete federal supply group as a means of identifying a group of NSNs to be cancelled in a single request. Requisitioners will still be able to use the federal supply classification (FSC), the national stock number (NSN), local stock number (LSN) (for BRAC IMSP sites), or contractor and government entity (CAGE)/Part Number as a means of identifying which items to cancel by materiel identification values.

Staffing Note #2: Components are requested to advise if FSG is currently used as criteria when initiating mass/universal cancellations. If it is used, then DLMSO will take action to add qualifier CG (Commodity Grouping) to the LIN02 of the DLMS 869C.

Navy Response: Navy does not use FSC or FSG as a selection criteria to initiate a mass cancellation.

Air Force Response: ILS-S does not have this capability. An approved ILS-S Requirement for a software code change would be required to implement this part.

DLA Response: DLA does not initiate these cancellations so no, we do not use FSC as a criteria.

Marine Corps Response: FSG is not used as criteria when initiating universal/mass cancellations.

Army Response: This hinges on Staffing Note #1; federal supply group is not being used.

DLMSO Disposition: FSG will be deleted as a means for identifying a group of NSNs to be cancelled in a single request.

(e) Enhance the functionality of the DLMS 869C to support current MILSTRIP procedures under mass/universal cancellations by allowing a single transaction to identify multiple ship-to activities and associated supply information (e.g., FSC, NSN, LSN, CAGE/Part Number) for each ship-to activity for mass/universal cancellation action. See Enclosure 4 for details.

Staffing Note #3: Components are requested to identify whether or not the DLMS 869C should be enhanced to provide unique supply information for each ship-to activity (when multiple ones apply to a single mass/universal cancellation). The hierarchical looping structure of the DLMS 869C can support this (see Enclosure 4 for design of this requirement). If the supply information is not unique between multiple ship-to activities covered by a single mass/universal cancellation request, then the IC can be simplified to just allow for multiple ship-to activities, with the assumption that any supply information applies to all of them.

Navy Response: As this functionality is not resident in Navy ERP currently, Navy has no preference to whether a single looped transaction will be used or multiple transactions; it's new development regardless.

Air Force Response: Concur with suggested enhancement for 869C.

DLA Response: DLA defers to the initiating activities.

Marine Corps Response: The DLMS 869C should be enhanced to provide unique supply information to each ship-to activity.

Army Response: GCSS-Army will accommodate provision of DLMS 869C in the requirement for Mass or universal cancellation when a decision to build the requirement is given or request changes to DLMS 869C if necessary.

DLMSO Disposition: The DLMS 869C and associated procedures will authorize the identification of multiple ship-to activities using the hierarchical level looping feature in the DLMS.

(2) ***Continuing High Priority Security Assistance Demands*** – Expand currently documented MILSTRIP procedure that restricts use of Special Requirements Code 555 to approved cooperative logistics supply support arrangement (CLSSA) requisitions with Type of Assistance Code U or V (the buying government has made cash payment to buy equity in DOD stocks) to apply to DLMS formatted transactions.

Staffing Note #4: DSCA is requested to validate that this is a valid MILSTRIP requirement using DLMS formatted transactions.

DSCA Response: DSCA concurs that CLSSA should be included in the procedures for mass cancellation exception utilizing RDD 555 as written.

DLMSO Response: This ADC expands this requirement to both DLMS and legacy MILS transaction processing.

(3) ***Source of Supply Processing of Mass/Universal Requisition Cancellation Requests to Procurement Activities*** – The DLMS 869C (MILSTRIP legacy DIC ACP/ACM) provides an electronic means for the SoS to send to procurement activities requests for mass/universal requisition cancellations. Components must be able to process this requirement using either MILSTRIP transactional exchange or internal equivalent. This requirement is clarified in the updated guidance.

(4) ***Source of Supply Processing of Mass/Universal Requisition Cancellations for Direct Vendor Delivery Sourced Requirements*** – If the procurement activity is unable to transmit either the confirmation of shipment diversion or the denial of shipment diversion, it will be presented to the SoS via internal system communication or offline means (e.g., email, phone), at which time the SoS will update its records accordingly.

(5) ***Follow-Ups to Mass/Universal Requisition Cancellations*** – The SoS will follow-up with the procurement or storage activity, as applicable, when no response to the original universal or mass requisition cancellation request has been received within three days. The SoS will follow-up to procurement activities via internal system communications or offline means (e.g., email, phone). For follow-ups to a storage activity, the SoS will use the DLMS 940R Follow-Up to Mass/Universal Requisition Cancellation (there is no MILSTRIP legacy equivalent); the DLMS 940R beginning segment will cite Code 82 (Follow-Up) in the 1/W0507/0200.

(6) ***Disposal Release Order Modification*** – Establish this process as an authorized DLMS enhancement in the DLMS 940R/MILSTRIP Legacy DIC AMJ.

Staffing Note #5: For DLA, does DLA either receive or generate DRO modifications? If so, can DSS accept and process a DRO modification? DLMSO is formalizing the associated procedures for use of a DRO Modification as an authorized DLMS enhancement.

DLA Response: DROs are generated by Distribution DSS, and received and processed by Disposition DSS. DSS has the ability to process an AMJ on the Distribution side of DSS. *Note: This type of modification in DSS (AMJ) used to be identified as a suffixed DTID in DAISY.

DLMSO Disposition: This DLMS change will establish DRO Modification as a DLMS enhancement using the DLMS 940R/MILSTRIP legacy DIC AMJ.

(7) Reply to Cancellation Request – Shipment Status – add Action Code W10 Diverted Item to the DLMS 856S beginning segment (BSN07) to differentiate shipment status indicating diversion action taken in lieu of allowing shipment to continue in transit. DLA Transaction Services will perpetuate this action code to downstream recipients of the shipment status.

(8) Disposition of Frustrated GSA Shipments/Materiel – With the closure of GSA Distribution Centers and removal of GSA from the Materiel Return Program, any frustrated shipments at ports of embarkation that are the result of mass or universal cancellation action will be held awaiting disposition instructions from GSA. The ports will contact GSA for the disposition instructions.

(9) Processing of Shipment Diversion Transactions by DLA Transaction Services – The maintenance of the transportation to supply documentation correlation (TSDC) file by DLA Transaction Services is discontinued. Confirmation of diversion requests will be handled directly between the transportation activity executing/reporting the diversion and the storage activity requesting the diversion. The storage activity will provide to the SoS the applicable DLMS 945A (MILSTRIP Legacy DIC AG6) or DLMS 945A (MILSTRIP Legacy DIC AE6) indicating the cancellation status. The DIC AU7 transaction format is deleted. The procurement activity will provide cancellation status to the SoS via internal system communication or offline means (e.g., email, phone).

(10) Staggered Implementation of Automated Mass/Universal Cancellation Process - Due to the magnitude of this DLMS change on various automated information systems, the SoS will need to be agile so as to coordinate execution of the cancellation request between the requesting activity and procurement/storage activities, regardless of the level of transaction automation available in the impacted systems.

(a) If an activity (e.g., requesting activity, SoS, storage activity) sends electronic transactions to DLA Transaction Services for routing and the recipient is not setup to receive those transactions, DAAS will reject those transactions back to the submitter citing status code CA; the accompanying narrative message will state that the intended recipient is not capable of receiving electronic transactions. Upon receipt of such a narrative message from DLA Transaction Services, the submitter will revert to offline means of communications (e.g., email, phone) with the intended recipient.

(b) Requesting activities unable to generate the DLMS 869C Request for Mass/Universal Requisition Cancellation may use one of the two following methods to document their requirement for entry into the DOD supply system.

1. Use the message format in DLMS 4000.25-1, MILSTRIP, Appendix 1.23 and send via offline methods to the applicable SoS for action,

2. Enter the information into the MILSTRIP Order Entry System (MOES) module in FEDMALL, which in turn will produce the DLMS 869C and transmit to DLA Transaction Services for routing.

(c) Procurement activities will continue to communicate with the SoS using internal system communications or off-line methods (e.g., email, phone); in response to procurement activity actions, the SoS will prepare the applicable outbound transactions to provide status to the requesting activity.

(d) If the storage activity is unable to send/receive the designated DLMS transactions, then the SoS will communicate with it offline and prepare the applicable outbound transactions to provide status to the requesting activity.

(e) Components using integrated ERPs should consider work-flowing the mass/universal cancellation status between personnel and system modules to streamline the business processing.

d. Revisions to DLM 4000.25 Manuals:

(1) Add new Chapter 27 to DLM 4000.25, Volume 2 to consolidate Mass and Universal Cancellation Procedures into a single chapter. See Enclosure 1.

(2) Update Chapter 4 of DLM 4000.25, Volume 2 to move Mass and Universal Cancellation Procedures to new Chapter 27. See Enclosure 2.

(3) Update Chapter 8 of DLM 4000.25-1 MILSTRIP to align with new Chapter 27 of DLM 4000.25, Volume 2. See Enclosure 3.

(4) Update DLM 4000.25, Volume 2, Appendix 7.1 and DLM 4000.25, MILSTRIP, Appendix 2.1 as follows:

Document Identifier Codes

CODE	DOCUMENT TITLE	EXPLANATION
AE6	Supply Status	To ICP/IMM from storage or reporting activity in response to a DIC AF6, AC6, AC7 , DIC series A4_ with Distribution Code 2, or A5_ series when a DIC AR_ series or DIC AS6 does not apply. Also for use in support of the Retail Transportation and Supply Receipt and Acknowledgment Interchange (transactions identified by a Distribution Code = 111) from transportation to retail supply activity to provide status, unsolicited, for cargo incheck, hold/delay status, supply status, and cancellation responses (DLM 4000.25, Volume 3, Chapter 2).
AG6	Reply to Cancellation Request	To ICP from storage activity
AMJ	Disposal Release Order Modification	To storage activity from ICP (Not applicable for MILSTRIP legacy formatted transactions; used for DLMS transaction exchange only).
AU7	Reply to Cancellation Request- Shipment Status	(To DAAS- Notification that Shipment shall be Subject to Diversion by DTS in Response to Request for Mass or Universal Cancellation)

(5) Update DLM 4000.25, Volume 2, Appendix 8.19 and DLM 4000.25, MILSTRIP, Appendix 3.19, Shipment Status, to remove reference to “AU7” since use of this transaction is formally withdrawn.

FIELD LEGEND	RECORD POSITION(S)	ENTRY AND INSTRUCTIONS
Document Identifier Code	1-3	Enter the DIC applicable to the shipment status (DIC AS1-6, AS8, or ASY) or reply to cancellation request-shipment status (AU1-5 7 , AU7 , or AU8).

(6) Update Table of Contents of DLM 4000.25, Volume 2 to add Chapter 27 entitled “Mass or Universal Cancellation of Requisitions”, include major paragraph headings, and removed related entries for Chapter 4.

(7) Update DLMS 869C, 940R, 856S Implementation Conventions. See Enclosure 4.

(8) Update the Logistics Data Resource Management System (LOGDRMS) Defense Logistics Standards Systems (DLSS) (also known as MILS)/Defense Logistics Management Standards (DLMS) Cross-Reference) as indicated below:

Logistics Qualifier **0:

FED DLMS IC	DIC / DESCRIPTION	REMARKS
940R	<i>AM_Materiel Release Order Modification</i>	
940R	<i>AM1 Materiel Release Order Modification - For Overseas Shipment with NSN/NATO Stock Number</i>	
940R	<i>AM2 Materiel Release Order Modification - For Overseas Shipment with Part Number</i>	
940R	<i>AM4 Materiel Release Order Modification - For Overseas Shipment with Other</i>	
940R	<i>AM5 Materiel Release Order Modification - For Overseas Shipment with Exception Data</i>	
940R	<i>AMA Materiel Release Order Modification - For Domestic Shipment with NSN/NATO Stock Number</i>	
940R	<i>AMB Materiel Release Order Modification - For Domestic Shipment with Part Number</i>	
940R	<i>AMD Materiel Release Order Modification - For Domestic Shipment with Other</i>	
940R	<i>AME Materiel Release Order Modification - For Domestic Shipment with Exception Data</i>	
940R	<i>AMJ Disposal Release Order Modification</i>	
945A	AE6 Supply Status - To ICP/IMM from Storage or Reporting Activity in Response to a DIC AF6, AC6, AC7, DIC Series A4_ with Distribution Code 2, or A5_ Series when a DIC AR_ Series or DIC AS6 does not Apply	
945A	AG6 Reply to Cancellation Request (to ICP from Storage Activity)	
945A	945A Reply to Cancellation Request - Shipment Status (to DAAS - Notification that Shipment will be Subject to Diversion by DTS in Response to Request for Mass or Universal Cancellation)	

Logistics Qualifier *0:

DIC	FED DLMS IC / DESCRIPTION	REMARKS
AE6	945A Supply Status - To ICP/IMM from Storage or Reporting Activity in Response to a DIC AF6, AC6, AC7 , DIC Series A4_ with Distribution Code 2, or A5_ Series when a DIC AR_ Series or DIC AS6 does not Apply	
AG6	945A Reply to Cancellation Request (to ICP from Storage)	
AM1	940R Materiel Release Order Modification - For Overseas Shipment with NSN/NATO Stock Number	
AM2	940R Materiel Release Order Modification - For Overseas Shipment with Part Number	
AM4	940R Materiel Release Order Modification - For Overseas Shipment with Other	
AM5	940R Materiel Release Order Modification - For Overseas Shipment with Exception Data	
AMA	940R Materiel Release Order Modification - For Domestic Shipment with NSN/NATO Stock Number	
AMB	940R Materiel Release Order Modification - For Domestic Shipment with Part Number	
AMD	940R Materiel Release Order Modification - For Domestic Shipment with Other	
AME	940R Materiel Release Order Modification - For Domestic Shipment with Exception Data	
AMJ	940R Disposal Release Order Modification	For DLMS information exchange only
AU7	945A Reply to Cancellation Request - Shipment Status (to DAAS - Notification that Shipment will be Subject to Diversion by DTS in Response to Request for Mass or Universal Cancellation)	

e. **Approved Transaction Flow:** See Enclosure 5 for mass/universal requisition cancellation transaction flow scenarios between the requesting activity, the SoS, and the storage activity/procurement activity.

f. **Alternatives:**

(1) Continue a mixed offline/systemic processing of mass and universal cancellations of requisitions. This is not practical as it creates systemic air gaps in processing and requires manual data entry in and out of automated systems, which can be prone to error.

(2) Continue maintaining two separate manuals requiring the reader to review both the DLM 4000.25-1, MILSTRIP manual for the core procedures, as well as DLM 4000.25, Volume 2, Chapter 4 for the DLMS enhanced procedures. This is not a viable alternative, as it is prone to errors in interpretation, cumbersome to extract mass and universal cancellation procedures from the current Volume 2, and labor intensive to maintain two sets of manuals.

5. REASON FOR CHANGE: Establish DLMS procedures for transaction exchange supporting mass/universal cancellation as an authorized DLMS enhancement. Consolidate mass and universal cancellation procedures into a single location and align both the Volume 2 and MILSTRIP manuals so that eventually the MILSTRIP manual can be canceled, with the Volume 2 manual serving as the single source for mass and universal cancellation procedures.

6. ADVANTAGES AND DISADVANTAGES:

a. Advantages:

(1) Fully systemic, end-to-end process for mass and universal cancellation of requisitions.

(2) Single source to document mass and universal cancellation procedures.

b. Disadvantages: This will require system changes to implement the DLMS 869C for requesting mass and universal cancellation of requisitions.

7. ESTIMATED TIME LINE/IMPLEMENTATION TARGET: Delayed implementation is authorized. Components are required to provide target implementation dates to DLMSO. Due to the degree of manual, offline processing in place today, reporting activities should coordinate with intended transaction recipients to ensure both parties are capable of processing the required DLMS transactions for this procedure.

8. ESTIMATED SAVINGS/COST AVOIDANCE ASSOCIATED WITH IMPLEMENTATION OF THIS CHANGE: Unknown.

9. IMPACT:

a. New DLMS Data Elements: There are no new DLMS data elements introduced by this DLMS change.

b. Changes to DLMS Data Elements:

(1) Modify Logistics Qualifier *0 and **0 as indicated in paragraph 4.d.(8).

(2) Add Action Code W10 (Diverted Item) to the DLMS 856S beginning segment (BSN07) to differentiate shipment status indicating diversion action taken in lieu of allowing shipment to continue in transit.

c. Component Automated Information Systems (AIS):

(1) Implement 869C for Mass/Universal Requisition Cancellations.

(2) Implement 856S enhancement to indicate if the shipment status in response to a mass/universal cancellation request indicates a diversion action versus allowing the shipment to continue in transit.

(3) Implement 940R enhancement to initiate follow-ups on mass/universal cancellation actions sent by the SoS to storage activities.

(4) Implement 940R enhancement to allow for Disposal Release Order modifications.

(5) Ensure internal procedures are established to support communications with the procurement activity via internal communications or offline methods (e.g., email, phone) for mass/universal cancellation actions.

d. DLA Transaction Services:

(1) Update DAAS maps for the 869C to align with the administrative corrections and enhancements documented in the DLMS IC table in Enclosure 4.

(2) Update DAAS maps for the 940R to align with the enhancements to allow Disposal Release Order Modifications and Follow-Ups to Mass/Universal Requisition Cancellation actions as documented in the DLMS IC table in Enclosure 4.

(3) Update DAAS maps for the 856S to align with the enhancement to identify an action code to differentiate shipment status indicating diversion action taken in lieu of allowing shipment to continue in transit. DLA Transaction Services will perpetuate this action code to downstream DLMS recipients of the shipment status.

(4) Be advised that the DAAS functionality for maintenance of the transportation to supply documentation correlation (TSDC) file is formally withdrawn and will be removed from MILSTRIP procedures by this DLMS change.

e. FEDMALL: Do not allow users to initiate a mass or universal cancellation via FEDMALL/MOES.

f. DLMSO Web Site: Update DLMSO web page for DLMS Implementation Conventions www.dla.mil/j-6/dlms/elibrary/TransFormats/140_997.asp as follows:

DLMS IC	DIC (Current)	DIC (Updated)
856S	AS1-6/AS8/ASY/AU or AU1-5/AU7-8	AS1-6/AS8/ASY/AU or AU1-5/AU7-8

g. Non-DLA Logistics Management Standards Publications: Components should update their local procedures to ensure consistency with mass and universal cancellation procedures documented in DLM 4000.25 and DLM 4000.25-1.

10. Comment Resolution for PDC 1132: See enclosure 6.

Enclosure 1

A. Add new Chapter 27 to DLM 4000.25 Volume 2.

C27. CHAPTER 27
MASS OR UNIVERSAL CANCELLATION OF
REQUISITIONS

C27.1. **GENERAL**

C27.1.1. **Purpose**. This chapter provides procedures for the request, generation, submission, and processing of mass and universal cancellations of requisitions. It also provides procedures for the disposition of frustrated shipments and materiel resulting from mass and universal cancellation actions.

C27.1.2. **Transactions**

C27.1.2.1. Request for Mass Cancellation of Requisitions Transaction is identified by the DLMS 869C by beginning segment (1/BSI08/20 Code AC and 1/BSI09/20 Code AW).¹ This transaction provides the functionality of the MILSTRIP Mass Cancellation Message (See Appendix 6.23). There is no MILSTRIP legacy document identifier code (DIC) equivalent.

C27.1.2.2. Request for Universal Cancellation of Requisitions Transaction is identified by the DLMS 869C by beginning segment (1/BSI08/20 Code AC and 1/BSI09/20 Code C).² This transaction provides the functionality of the MILSTRIP Universal Cancellation Message (See Appendix 6.23). There is no MILSTRIP legacy DIC equivalent.

C27.1.2.3. Requisition Modification Transaction is identified by the DLMS 511M by beginning segment (1/BR02/020 Code AM). This transaction provides the functionality of MILSTRIP legacy DIC AM1, AM2, AM4, AM5, AMA, AMB, AMD, and AME.

C27.1.2.4. Materiel Release Order Modification Transaction is identified by the DLMS 940R by beginning segment (1/W0506/0200 Code NA and 1/W0507/0200 Code 2). This transaction provides the functionality of passing the MILSTRIP legacy DIC AM1, AM2, AM4, AM5, AMA, AMB, AMD, and AME from the source of supply (SoS) to the storage activity.

C27.1.2.5. Disposal Release Order Modification Transaction is identified by the DLMS 940R by beginning segment (1/W0506/0200 Code NE and 1/W0507/0200 Code 2). This transaction provides the functionality of passing the MILSTRIP legacy DIC AMJ.

¹ Mass cancellation and follow-on transactions are DLMS enhancements. Refer to ADC 1132. Delayed implementation authorized.

² Universal cancellation and follow-on transactions are DLMS enhancements. Refer to ADC 1132. Delayed implementation authorized.

C27.1.2.6. Inventory Control Point Requisition Modification Transaction is identified by the DLMS 511M by beginning segment (1/BR02/020 Code AM and 1/BR06/020 Code 2). This transaction provides the functionality of MILSTRIP legacy DIC AMP.

C27.1.2.7. Universal Requisition Cancellation to Storage Activity Transaction is identified by the DLMS 940R by beginning segment (1/W0506/0200 Code ND) and DIC AC7 (2/LQ01/1300 Code 0). This transaction provides the functionality of MILSTRIP legacy DIC AC7.

C27.1.2.8. Universal Requisition Cancellation to Procurement Activity Transaction is identified by the DLMS 869C by beginning segment (1/BSI08/20 Code AC and 1/BSI09/20 Code C) and DIC ACM (2/LQ01/180 Code 0). This transaction provides the functionality of MILSTRIP legacy DIC ACM.

C27.1.2.9. Mass Requisition Cancellation to Storage Activity Transaction is identified by the DLMS 940R by beginning segment (1/W0506/0200 Code ND) and DIC AC6 (2/LQ01/1300 Code 0). This transaction provides the functionality of MILSTRIP legacy DIC AC6.

C27.1.2.10. Mass Requisition Cancellation to Procurement Activity Transaction is identified by the DLMS 869C by beginning segment (1/BSI08/20 Code AC and 1/BSI09/20 Code AW) and DIC ACP (2/LQ01/180 Code 0). This transaction provides the functionality of MILSTRIP legacy DIC ACP.

C27.1.2.11. Follow-Up to Storage Activity for Mass/Universal Requisition Cancellation Transaction is identified by the DLMS 940R by beginning segment (1/W0506/0200 Code ND and 1/W0507/0200 Code 82). There is no MILSTRIP legacy equivalent DIC.

C27.1.2.12. The Supply Status Transaction is identified by the DLMS 870S by two different beginning segment (1/BSR01/020) Transaction Type Codes.

C27.1.2.12.1. Transaction Type Code 4 – Response to Requisition. This transaction provides the functionality of MILSTRIP legacy DIC AE1, AE2, AE3, AE8, AE9, AEA, AEB, AED, and AEE.

C27.1.2.12.2. Transaction Type Code 5 – Notice of Response to Direct Vendor Delivery. This transaction provides the functionality of MILSTRIP legacy DIC AB1, AB2, AB3, and AB8.

C27.1.2.13. The Reply to Cancellation Request – Shipment Status is identified by the DLMS 856S by beginning segment (1/BSN06/0200 Code AS) and DICs AU1, AU2, AU3, AU4, AU5, AU8 (2/LQ01/3500 Code 0). This transaction provides the functionality of MILSTRIP Legacy DIC AU1, AU2, AU3, AU4, AU5, AU8.

C27.1.2.14. The Reply to Cancellation Request – Materiel Release Confirmation is identified by the DLMS 945A by beginning segment (1/W0611/0200 Code NJ). This transaction provides the functionality of MILSTRIP Legacy DIC AU0, AUA, and AUB.

C27.1.2.15. The Reply to Cancellation Request is identified by the DLMS 945A by beginning segment (1/W0611/20 Code NR). This transaction provides the functionality of MILSTRIP Legacy DIC AG6.

C27.1.2.16. The Storage Activity Supply Status is identified by the DLMS 945A by beginning segment (1/W0611/20 Code NL). This transaction provides the functionality of MILSTRIP Legacy DIC AE6.

C27.2. Applicability

C27.2.1. Events such as base closures, termination of special projects, ship and unit inactivations, termination of agreements, and termination of vessel outfitting or construction can necessitate the requirement for mass or universal cancellation.

C27.2.2. Although these events may ultimately require mass or universal cancellation action, they are normally known to the affected activities well in advance of the effective date of such closures or termination action. In these instances, every effort will be made by the requisitioning activity to minimize the continued processing of requisitions by the sources of supply (SoS), and the subsequent entry of unwanted shipments into the Defense Transportation System (DTS), through initiation and processing of single line-item cancellations (See Chapter 4).

C27.2.3. When a total project (or total requirement for a single base) is no longer required and should be canceled and it is known that insufficient time remains to permit continued cancellation on a single line basis, a mass cancellation or universal cancellation request may be initiated.

C27.2.3.1. A mass cancellation permits continued supply action and shipment processing for selected requisitions.

C27.2.3.2. A universal cancellation serves to terminate all such processing, even requisitions previously identified for continued supply action and shipment processing under mass cancellation situations.

C27.2.3.3. Under extreme conditions, a mass cancellation may be superseded by a universal cancellation.

C27.2.4. Requisitions that require continued supply action and shipment processing under mass cancellation situations must be identified by the requiring activity at the earliest date through submission of a Requisition Modification (DLMS 511M) citing Special Requirements Code 555³.

C27.2.4.1. The requisition may not be modified to cite Special Requirements Code 555 after the effective date of the requested mass cancellation; however, requisition

³ Code 555 identified in the required delivery date field for MILSTRIP legacy transactions.

modifications submitted to change other data elements when the Special Requirements Code 555 was previously entered must perpetuate the Special Requirements Code 555.⁴

C27.2.4.2. Requisitions containing, or modified to contain, Special Requirement Code 555 will receive processing precedence under Chapter C4.

C27.2.5. When a universal cancellation is initiated to supersede a mass cancellation and there are outstanding requisitions or requisition modifications citing Special Requirements Code 555, the SoS will provide a Universal Requisition Cancellation to Storage Activity (DLMS 940R/DIC AC7) or a Universal Requisition Cancellation to Procurement Activity (DLMS 869C/DIC ACM) for all outstanding requisitions, regardless of the presence of a Special Requirements Code 555.

C27.3. INITIATION OF MASS OR UNIVERSAL CANCELLATION OF REQUISITIONS

C27.3.1. Only designated personnel within an organization may initiate requests for mass or universal cancellation of requisitions. The Component's requisitioning system will ensure that only authorized users initiate these requests. If there are any questions regarding the authenticity of a mass/universal cancellation, contact either the Component Supply PRC Representative or the customer support representative for the source of supply. Component Supply PRC Representatives are identified on the DLMSO Website at <https://www2.dla.mil/j-6/dlms0/CertAccess/SvcPointsPOC/allpoc.asp>. The mass or universal cancellation request will be accomplished by preparation of the DLMS 869C or the message format reflected in Appendix AP6.23.

C27.3.1.1. Inter-Component dissemination of requests for mass or universal cancellation must be coordinated in advance to determine if the DLMS 869C or message format will be used. If using the message format, the requesting Component must identify the authorized recipient from the Component to process the mass or universal cancellation. If it is not known, contact either the Component's Supply PRC representative or the customer support representative for the source of supply to identify the point of contact.

C27.3.1.2. Intra-Component dissemination of requests for mass or universal cancellations must be performed by the authorized Component contact point. Intra-Component dissemination will include all Component supply sources, storage sites, and other activities within the DoD Component processing MILSTRIP documentation or shipments with capability to cancel requisitions or divert shipments. In addition, the designated Component contact points must ensure that the appropriate overseas theater, force, logistics, or type commanders are cognizant of mass or universal cancellation actions affecting their areas of responsibility.

C27.3.2. Due to the requirement to ensure that mass/universal cancellation requests are only initiated by authorized personnel, these cancellations must not be initiated through use of DOD EMALL, or its replacement system FEDMALL.

⁴ Revised requisition modifier procedures last reported as not implemented by U.S. Marine Corps (USMC). Refer to Approved MILSTRIP Change Letter (AMCL) 123C.

C27.3.3. Required Data Content. Requests for mass or universal cancellation action will be submitted to the applicable SoS for cancellation of all open requisitions applicable to specific projects or bases. The request for mass or universal cancellations will contain identification of the activity submitting the request, the effective date, and the required codes for identification of one of the following, for which cancellation of all applicable requisitions is requested:

C27.3.3.1. One Project code and one ship-to DoDAAC

C27.3.3.2. No project code and one ship-to DoDAAC

C27.3.3.3. One project code and multiple ship-to DoDAACs

C27.3.3.4. No project code and multiple ship-to DoDAACs

C27.3.3.5. Multiple project codes and one ship-to DoDAAC

C27.3.3.6. Federal supply classification (FSC), national stock number (NSN), local stock number (LSN), or CAGE/part number when associated with the address of the original requisition document number ship-to address and/or project code.

C27.3.4. Customers retain the authority to submit single line-item cancellation requests via DLMS 869C/DICs AC1/AC2/AC3 at any time before, during, or after the mass cancellation effective date.

C27.4. CONTINUING HIGH PRIORITY DEMANDS DURING A MASS CANCELLATION

C27.4.1. A need may exist to continue the processing of certain requisitions and shipments during mass cancellations such as high priority demands to satisfy not mission capable supply (NMCS) conditions (identified by Special Requirements Code 999 or N in the requisition). In addition, a need may exist to allow continued processing of requisitions for materiel required to effect base closure. In these instances, submit a requisition modification citing Special Requirements Code 555 to the SoS prior to the submission of the mass cancellation request. For Security Assistance, use of Special Requirements Code 555 is restricted to approved cooperative logistics supply support arrangement (CLSSA) requisitions with Type of Assistance Code U or V (the buying government has made cash payment to buy equity in DoD stocks). Sources of supply will not cancel requisitions that have been modified to contain Special Requirements Code 555 during a mass cancellation process. If submitting the mass cancellation request via offline message, then cite one of the following selective criteria in the special instructions segment of the message:

C27.4.1.1. Project code(s) when associated with the ship-to DoDAAC being canceled

C27.4.1.2. Special Requirements Code 999 or N when associated with the ship-to DoDAAC being canceled

C27.4.1.3. FSC, NSN, or CAGE/part number when associated with the ship-to DoDAAC being canceled

C27.4.1.4. Specific requisition document number(s) and routing identifier code (RIC)-From the status received or the RIC-To which the requisition has been transmitted if status has not been received

C27.4.1.5. Specific priority designator (PD) when associated with the ship-to address DoDAAC being canceled

C27.4.1.6. Required delivery period (RDP) when associated with the ship-to address DoDAAC being canceled - conventional ammunition only.⁵

C27.4.2. Upon receipt of Requisition Modifications citing continued processing action during a mass cancellation, SoS, storage activities, and procurement sources must annotate the affected requisition(s) and all associated transactions/records with Special Requirements Code 555.

C27.4.3. Upon receipt of either the Request for Mass Cancellation transaction or the offline Mass Cancellation message citing selective criteria for continued processing action in the special instructions segment, the SoS must review all prospective cancellations to identify those for which continued processing has been requested. For continued processing of requisitions at storage activities, the SoS will provide a Materiel Release Order Modification (for MILSTRIP legacy processing, pass the Requisition Modification) to the Storage Activity. In the case of items scheduled for direct vendor delivery, the SoS must forward ICP Requisition Modifications (DIC AMP) to procurement sources.

C27.4.4. The Defense Transportation System (DTS) will continue movement of materiel to which Special Requirements Code 555 has been applied except when a universal cancellation has been announced.

C27.5. SOURCE OF SUPPLY PROCESSING MASS OR UNIVERSAL CANCELLATION REQUESTS

C27.5.1. Sources of supply are responsible for ensuring that requisition processing, procurement, and storage activities exercise the fullest practical resourcefulness in preventing the issue and shipment of unwanted materiel. The practical considerations involved in the processing of cancellation requests include such factors as time, packing and handling, related costs, and location of materiel for which cancellation is requested.

C27.5.2. The SoS must cancel all requisitions dated on or prior to the effective date announced in mass or universal cancellation requests for which materiel release orders (MROs), and/or purchase requests have not been submitted to storage or procurement activities. Provide a Supply Status transaction citing Status Code BQ or B4, as appropriate,

⁵ Use of RDP for conventional ammunition last reported as not implemented by U.S. Air Force (USAF). Refer to AMCL 148.

as notice of accomplished cancellations to all eligible status recipients under Chapter 5 within the timeframe for furnishing status.

C27.5.3. The SoS will furnish Supply Status transactions citing Status Code B9 to all eligible recipients under Chapter 5 within the timeframes for furnishing status for:

C27.5.3.1. Unconfirmed cancellation of open MROs and open procurement actions.

C27.5.3.2. Materiel release confirmations (MRCs) that indicate shipment to OCONUS activities within 45 days of the effective date of the mass cancellation.

C27.5.4. Provide subsequent Supply Status transactions citing Status Codes BQ, B4, or B6 as notification for each line-item canceled or diverted. Cite Status Code B8 for each line-item that was not canceled or diverted.

C27.5.5. The SoS will provide storage activities with mass requisition cancellation transactions (DLMS 940R/DIC AC6) and universal requisition cancellation transactions (DLMS 940R/DIC AC7) for all unconfirmed MROs and MRCs that indicate shipment to OCONUS activities within 45 days of the effective date of the mass or universal cancellation.

C27.5.6. The SoS will provide procurement activities with mass requisition cancellation transactions (DLMS 869C/DIC ACP) and universal requisition cancellation transactions (DLMS 869C/DIC ACM) for all open procurement actions. These transactions are mandatory when purchase requests have been issued to another Component. If processed within an integrated Component system, equivalent internal transactions may be used.

C27.5.7. The SoS will not provide storage and procurement activities with cancellation requests when:

C27.5.7.1. In receipt of MRCs that show shipment has been accomplished by parcel post (USPS),

C27.5.7.2. In receipt of MRCs that show shipment to CONUS activities has been accomplished, and

C27.5.7.3. In receipt of MRCs that show shipment to OCONUS customers was accomplished more than 45 days prior to the receipt of the mass or universal cancellation request.

C27.5.8. The SoS will follow-up with the procurement or storage activity, as applicable, when no response to the original universal or mass requisition cancellation request has been received within three days. The SoS will follow-up to procurement activities via internal system communications or offline means (e.g., email, phone). For follow-ups to a storage activity, the SoS will use the DLMS 940R Follow-Up to Storage Activity for Mass/Universal Requisition Cancellation (there is no MILSTRIP legacy equivalent).

C27.6. STORAGE ACTIVITY PROCESSING OF MASS OR UNIVERSAL REQUISITION CANCELLATIONS

C27.6.1. Upon receipt of the mass or universal requisition cancellation transaction(s) from the SoS, the storage activity will identify all affected MROs where the items have not been released to a carrier for delivery to the consignee.

C27.6.1.1. For mass cancellation, the storage activity will not suspend processing of MROs identified for continued processing under paragraph C27.4.

C27.6.1.2. For universal cancellation, the storage activity will suspend further processing of all MROs, including any citing Special Requirements Code 555.

C27.6.2. For CONUS shipments, storage activities will accomplish cancellation for all items for which mass or universal requisition cancellation transactions are received from SoS and the items have not been released to a carrier for delivery to the consignee.

C27.6.3. Storage activities will advise the SoS of actions taken in response to cancellation requests. When a shipment has not been released to the carrier for delivery to consignee and cancellation is accomplished, the storage activity will send the SoS a Reply to Cancellation Request transaction (DIC AG6) citing Status Code BQ.

C27.6.4. For shipments already released to a carrier for delivery to the consignee not meeting the criteria stipulated in paragraph C27.5.7., the storage activity will generate a Reply to Cancellation Request – Shipment Status (DLMS 856S/DIC AU_) for routing by DLA Transaction Services under standard MILSTRIP procedures for shipment status. It will also generate the Storage Activity Supply Status (DLMS 945A/DIC AE6) to the SoS.

C27.6.4.1. For CONUS shipments and those OCONUS shipments that meet the mass or universal cancellation criteria and have entered the DTS within 45 calendar days of the date of the mass or universal requisition cancellation request, the storage activity will cite Action Code W10 in the Reply to Cancellation Request – Shipment Status to indicate actions are being taken to divert the shipment.

C27.6.4.2. The Storage Activity Supply Status transaction to the SoS will cite Status Code B9 indicating that action is being taken to cancel/divert the shipment.

C27.6.5. When storage activities do not accomplish cancellation, the source of supply will be furnished a Storage Activity Supply Status transaction (DLMS 945A/DIC AE6) citing Status Code B8.

C27.6.6. Storage activities in receipt of transportation confirmation of shipment diversion transactions will send to the appropriate SoS a Reply to Cancellation Request transaction (DIC AG6) citing Status Code B6 for each requisition contained within the shipment unit. The transaction will also cite the DoD activity address code (DoDAAC) of the new consignee.

C27.6.7. Storage activities in receipt of transportation denial of shipment diversion transactions will generate a Reply to Cancellation Request – Materiel Release Confirmation (DIC AU0/AUA/AUB) to the appropriate source of supply. This transaction will be prepared under Appendix AP8.14.

C27.6.8. Upon receipt of a DLMS 940R Follow-Up to Storage Activity for Mass/Universal Requisition Cancellation, the storage activity will respond with the appropriate transaction as outlined in the preceding procedures for storage activity processing of these cancellation requests.

C27.7. DIRECT VENDOR DELIVERY PROCESSING OF MASS OR UNIVERSAL REQUISITION CANCELLATIONS

C27.7.1. All rules governing the single-line cancellation of shipments from procurement also apply to requests for mass or universal requisition cancellation, except as modified herein. Where DLMS/DIC transactions are identified for exchange of reporting events between the SoS and the procurement activity, internal system or off-line communications (e.g., email, phone), are authorized when procurement systems are not capable of supporting the MILSTRIP transactions.

C27.7.2. The SoS will initiate universal requisition cancellation transactions (DIC ACM) and mass requisition cancellation transactions (DIC ACP) for all items scheduled for direct delivery, and for which purchase requests have been submitted, regardless of materiel costs, unless continued processing has been requested under Paragraph C27.4.

C27.7.2.1. Mass cancellation will not be requested for requisitions citing Special Requirements Code 555.

C27.7.2.2. Universal cancellation will be requested regardless of the entry in the Special Requirements field.

C27.7.3. Procurement activities will advise the SoS of actions taken in response to cancellation requests. When a shipment has not been released to the carrier for delivery to consignee and cancellation is accomplished, the procurement activity will send the SoS a Reply to Cancellation Request transaction (DIC AG6) citing Status Code BQ or B4. Procurement activities will not initiate actions with the DTS to cause diversion of shipments at terminals.

C27.7.4. For shipments already released to a carrier for delivery to the consignee not meeting the criteria stipulated in paragraph C27.5.7., the procurement activity will generate the Storage Activity Supply Status (DLMS 945A/DIC AE6) to the SoS. The SoS will generate, on behalf of the procurement activity, a Reply to Cancellation Request – Shipment Status (DLMS 856S/DIC AU_) for routing by DLA Transaction Services under standard MILSTRIP procedures for shipment status.

C27.7.4.1. For CONUS shipments and those OCONUS shipments that meet the mass or universal cancellation criteria and have entered the DTS within 45 calendar days of the date of the mass or universal requisition cancellation request, the SoS will cite Action

Code W10 in the Reply to Cancellation Request – Shipment Status to indicate actions are being taken to attempt to divert the shipment.

C27.7.4.2. The Storage Activity Supply Status transaction to the SoS will cite Status Code B9 indicating that action is being taken to cancel/divert the shipment. This status will be perpetuated by the SoS in a Supply Status transaction to the requesting activity.

C27.7.5. Procurement activities in receipt of confirmation of shipment diversion transactions will send to the appropriate SoS a Reply to Cancellation Request transaction (DIC AG6) SoS citing Status Code B6 for each requisition contained within the shipment unit. The transaction will also cite the DoDAAC of the new consignee.

C27.7.6. Procurement activities in receipt of denial of shipment diversion transactions will send to the appropriate SoS a Reply to Cancellation Request – Materiel Release Confirmation transaction (DIC AU0/AUA/AUB).

C27.7.7. If the procurement activity is unable to transmit either the confirmation of shipment diversion or the denial of shipment diversion, it will be presented to the SoS via internal system communication or offline means (e.g., email, phone), at which time the SoS will update its records accordingly.

C27.7.8. Upon receipt of a DLMS 869C Follow-Up to Procurement Activity for Mass/Universal Requisition Cancellation, the procurement activity will respond with the appropriate transaction as outlined in the preceding procedures for procurement activity processing of these cancellation requests.

C27.8. DTS PROCESSING OF MASS OR UNIVERSAL REQUISITION CANCELLATIONS

C27.8.1. Diverting Outside the Continental U.S. Shipments. When outside the continental U.S. (OCONUS) shipments have already departed from continental U.S. (CONUS) ports, the responsibility for diversion or disposition is that of the consignee or the appropriate theater, force, logistics, or type commander. Notice to the latter will be the transportation lift data provided by the DTS clearance authority. (See paragraph C27.9.4.)

C27.8.2. Diverting Continental U.S. Shipments. No attempt will be made to divert materiel destined to CONUS customer activities beyond the point of shipment.

C27.8.3. Designated Storage Points. All shipping DoD Components will designate storage points within their distribution system to receive shipments redirected as a result of mass or universal cancellation. Fund citations for bill of lading (BL) preparation must also be provided. These designated points and fund citations will be provided to Air Mobility Command (AMC), Military Surface Deployment and Distribution Command (SDDC), or theater commanders and will serve as predesignated consignees for any announced mass or universal cancellation. If more than one storage point is designated, instructions will be furnished to specify on a geographical basis the storage point designation in relation to each range of water and aerial ports (e.g., west, gulf, and east coasts). In addition, canceling DoD Components will designate a contact point(s) to provide disposition instructions on materiel that does not meet the automatic diversion conditions specified in paragraph C27.9.

Designated points of contact will provide requested disposition instructions to DTS within 24 hours on materiel located at air terminals and within 48 hours on materiel located at water terminals.

C27.9. DISPOSITION OF FRUSTRATED SHIPMENTS/MATERIEL

C27.9.1. The disposition of frustrated shipments at water ports of embarkation (WPOE)/aerial ports of embarkation (APOE) that are the result of mass or universal cancellation action will be as follows:

C27.9.1.1. Shipments from DoD storage points or from commercial vendors acting under the direction of a DoD procuring activity will be diverted to the predesignated storage sites of the shipping/procuring DoD Component.

C27.9.1.2. Shipments from General Services Administration (GSA) commercial vendors acting under the direction of a GSA procuring activity will be disposed under normal excess/surplus/donation procedures. The shipments will not be diverted to GSA facilities.⁶

C27.9.1.3. DTS attempts to divert/frustrate shipments will terminate 45 calendar days from the effective date of the mass or universal cancellation request.

C27.9.2. Certain strategic and tactical operations or political considerations may dictate that all shipments for a given consignee be stopped or diverted. In these most restrictive of shipment diversion situations and economic considerations (e.g., the comparison of accessorial cost of stopping, holding, and returning the materiel to storage activities), the value of the canceled materiel and the costs of the receiving activity to perform the necessary processing or reprocessing of the materiel are not controlling factors. In most situations, however, the strategic, tactical, or political environment is such that complete disregard of these economic considerations is not warranted.

C27.9.3. Transportation diversion procedures are established to permit diversion only if the materiel being shipped can be identified and located by TCN.

C27.9.3.1. Non-Consolidated Shipment Units. Shipment units eligible for cancellation that have not been consolidated into a container with other shipments will be stopped and diverted by the POE up to the point of lift. Diversion of cancellation eligible shipments at or beyond the port of debarkation (POD) will be the responsibility of the appropriate theater, force, logistics, or type commander.

C27.9.3.2. Consolidated Multiple Shipment Units. Individual line-items will not be removed from multiple-line shipment units (consolidated packs), nor will a shipment unit container be removed from a multi-container shipment (SEAVAN) type device. Shipment units cannot be diverted in the DTS if stuffed or loaded with other shipment units or on multiple shipment unit devices; such as, SEAVANS, container express (CONEX), MILVANS (Military Van), and Aircraft 463L pallets.

⁶ Refer to ADC 1142, Update to Remove General Services Administration (GSA) from MILSTRIP Materiel Returns Program (MRP)

C27.9.4. For mass or universal cancellation requests that specify FSC, NSNs/LSNs, or part number data, the DTS will stop and frustrate, for the DoD Component review, all shipments of the canceling DoD Component for the affected consignees. Disposition of cancellation eligible shipments at or beyond the POD will be the responsibility of the appropriate theater, force, logistics, or type commander.

C27.9.5. The DTS will generate specified documentation for the following shipment categories:

C27.9.5.1. For all shipments that are diverted as a result of mass or universal cancellation, the DTS will contact the shipper to confirm shipment diversion. The confirmation of shipment diversion will contain complete Transportation Control and Movement Document (TCMD) data for each shipment unit and, if available, the contract number. In addition:

C27.9.5.1.1. For shipments that are diverted under pre-positioned instructions, the DTS will generate appropriate DTR 4500.9R, "Defense Transportation Regulation" transactions to the new consignee.

C27.9.5.1.2. For shipment units that are frustrated and were not diverted to a specific site, the DTS will send a request for disposition instructions to the appropriate Component contact points. In situations where the designated DoD Component contact point is a collocated liaison office, the request for disposition instruction transactions will be listed and provided to the contact point directly. After receipt of disposition instructions for such frustrated shipments, the DTS will prepare appropriate [DTR](#) transactions for the new consignee.

C27.9.5.1.3. For shipments in transit to, at, or between the POD and the OCONUS consignee, OCONUS DTS activities will request disposition instructions from the appropriate theater, force, logistics, or type commander's designated contact point.

C27.9.5.2. For shipments in transit between WPOE/APOE and the OCONUS consignee less than 30 days, the DTS will generate a listing of the manifest shipment unit data, vessel/aircraft identification and departure date, water port of debarkation (WPOD)/aerial port of debarkation (APOD) and estimated time of arrival (ETA). This listing will be sent to the affected OCONUS command component, the appropriate WPOD/APOD, and to the designated contact point, if requested.

C27.9.6. Storage sites in receipt of diverted shipments will report the receipt to the appropriate SoS under Chapter 13. Reconsignment/disposition will be as directed.

C27.9.7. Specific instructions concerning materiel transportation charges and credit allowances are contained in the [DoD 7000.14-R](#), "Department of Defense Financial Management Regulations (FMRS)," (Vol 11B), Federal Property Management Regulation ([FPMR](#)) [101-26.311](#), and [FPMR 101-27.505](#). The Component initiating the cancellation requests applicable to U.S. Forces requisitions will be charged with the following:

C27.9.7.1. Transportation and terminal costs associated with holding, stopping, and returning materiel to storage,

C27.9.7.2. Procurement termination costs when it is determined that termination is in the best interest of the Government, and

C27.9.7.3. Excess transportation costs that may be incurred when moving cargo that is unaffected by the mass or universal cancellation action.

Enclosure 2

A. Update Chapter 4 to DLM 4000.25, Volume 2 by mass and universal cancellation related information and moving it to the new Chapter 27. Removed text is identified by ~~double strikethroughs~~. Removed paragraphs have been marked as **RESERVED** to avoid renumbering of the remaining paragraphs in the chapter.

C4. CHAPTER 4

REQUISITIONING

[Intervening text not shown]

C4.4.2. ~~Mass or Universal Cancellation of Requests~~ **Reserved.**

~~C4.4.2.1. General. Base closures, termination of special projects, ship and unit inactivation, termination of agreements, or termination of vessel outfitting or construction, are events that can necessitate the requirement for a mass or universal cancellation of multiple lines. Although these events may ultimately require mass or universal cancellation action, they are normally known to the affected activities well in advance of the effective date of such closures or termination action. In these instances, every effort will be made by the requisitioning activity to minimize the continued processing of requisitions by the sources of supply, and the subsequent entry of unwanted shipments into the Defense Transportation System (DTS), through initiation of single line item cancellations. When the DoD Component is aware that a total project (or total requirement for a single base) is no longer required and should be canceled and there is insufficient time remaining to permit continued cancellation on a single line basis, the DoD Component may initiate a mass or universal cancellation request of multiple lines by indicating a date range for the applicable requisition transaction number dates, appropriate project code(s) and/or various organizations.~~

~~C4.4.2.1.1. Mass Cancellation. A mass cancellation permits continued supply action and shipment processing for selected requisitions.~~

~~C4.4.2.1.2. Universal Cancellation. A universal cancellation serves to terminate all such processing, even requisitions previously identified for continued transaction and shipment processing under mass cancellation situations.~~

~~C4.4.2.2. Requirements for Continued Shipment. Requisitions that require continued supply action and shipment processing under mass cancellation situations must be identified by the requiring activity at the earliest date through submission of requisition modifiers, DLMS 511M, Requisition Modification, containing Special Requirements Code 555 in the LQ segment. For SA, use of this code is restricted to approved CLSSA requisitions with Type of Assistance Code U or V. Sources of supply will not cancel requisitions that have been modified to contain Special Requirements Code 555 during a mass cancellation process.~~

~~C4.4.2.2.1. Requisition Changes. The requisition may not be changed to contain Special Requirements Code 555 by means of a requisition modification submitted after the effective date of the requested mass cancellation.~~

~~C4.4.2.2.2. Applicability. Requisitions that fall within the scope of the announced mass cancellation criteria submitted after the effective date of the mass cancellation action, must contain Special Requirements Code 555.~~

~~C4.4.2.3. Initiation of Requests. Requests for mass or universal cancellation of requisitions will be initiated by the DoD Component or by an authorized command element. The DoD Component contact points established for issuance and receipt of requests for mass and universal cancellation are listed on the Defense Logistics Management Standards website at www.dla.mil/j-6/dlms/eLibrary/Restricted/SvcPointsPOC/default.asp. Inter DoD Component dissemination of requests for mass or universal cancellation must be made by the designated contact points. The mass or universal cancellation request will be accomplished by preparation of the DLMS 869C.~~

~~C4.4.2.4. Dissemination of Intra DoD Component S/A Requests. Intra DoD Component dissemination of requests for mass or universal cancellations will be accomplished by the DoD Component contact point designated. Intra DoD Component dissemination will include all Component sources of supply, storage activities, and other activities within the DoD Component processing supply transactions or shipments with capability to cancel requisitions or divert shipments. In addition, the designated DoD Component contact points will ensure that the appropriate overseas theater, force, logistics, or type commanders are aware of mass or universal cancellation actions affecting their areas of responsibility.~~

~~C4.4.2.5. Required Information. Requests for mass or universal cancellation action, DLMS 869C, Cancellation, will be submitted to the DoD Component designated contact point(s) for cancellation of all open requisitions applicable to specific projects, or bases (as identified by AACs). The request for mass or universal cancellations will contain identification of the activity having submitted the request, the effective date, and the required codes for identification of one of the following, for which cancellation of all applicable requisitions is requested:~~

~~C4.4.2.5.1. Project code and ship to address.~~

~~C4.4.2.5.2. One project code and various addresses.~~

~~C4.4.2.5.3. No project code and various addresses.~~

~~C4.4.2.5.4. Various project codes and one address.~~

~~C4.4.2.5.5. Federal supply classification (FSC), Federal supply group (FSG), NSN, or part number when associated with the address of the original requisition document number ship to address and/or project designator.~~

~~C4.4.2.6. Continuing High Priority Demands. A need may exist to continue the processing of certain requisitions and shipments during mass cancellations such as high priority demands to satisfy NMCS conditions (identified by Special Requirements Code 999 or N in the requisition). In addition, a need may exist to allow continued processing of requisitions for materiel required to effect base closure. In these instances, submit a requisition modification, containing Special Requirements Code 555 in the LQ segment and one of the following selective criteria, to applicable sources of supply prior to the submission of the mass cancellation request:~~

~~C4.4.2.6.1. Project code(s) when associated with the ship to address being canceled.~~

~~C4.4.2.6.2. Special Requirements Code 999 or NB when associated with the ship to address being canceled.~~

~~C4.4.2.6.3. FSC, FSG, NSN, or part number when associated with the ship to address being canceled.~~

~~C4.4.2.6.4. Specific requisition document number and RIC from the status received or the RIC to which the requisition has been transmitted if status has not been received.~~

~~C4.4.2.6.5. Specific PD when associated with the ship to address being canceled.~~

~~C4.4.2.6.6. Required Delivery Period (RDP) when associated with the ship to address being canceled—conventional ammunition only.~~

~~C4.4.2.7. Identifying Continued Processing Requests. Upon receipt of the requisition modification containing Special Requirements Code in the LQ segment reflecting a high priority demand and one of the above selective criteria, sources of supply will review all affected requisition(s) and all associated transactions to identify those for which continued processing has been requested. In the case of items scheduled for direct delivery, the source of supply will forward requisition modifications to procurement sources. Sources of supply, storage activities, and procurement sources will annotate the affected requisition(s) and all associated transactions with Special Requirements Code 555 in the LQ segment.~~

~~C4.4.2.8. DTS Processing. DTS will continue movement of materiel to which a Special Requirements Code 555 has been applied except when a universal cancellation has been announced.~~

~~C4.4.2.9. Diverting OCONUS Shipments. When OCONUS shipments have already departed from CONUS ports, the responsibility for diversion or disposition is that of the consignee or the appropriate theater, force, logistics, or type commander. Notice to the latter will be the transportation lift data provided by the DTS clearance authority. (See paragraph C4.7.25.10.)~~

~~C4.4.2.10. Diverting CONUS Shipments. No attempt will be made to divert material destined to CONUS customer activities beyond the point of shipment.~~

~~C4.4.2.11. Designated Storage Points. All shipping DoD Components will designate storage points within their distribution system to receive shipments redirected as a result of mass or universal cancellation. Fund citations for bill of lading (BL) preparation must also be provided. These designated points and fund citations will be provided to Air Mobility Command (AMC), Military Surface Development and Distribution Command (SDDC), or theater commanders, and will serve as pre-designated consignees for any announced mass or universal cancellation. If more than one storage point is designated, instructions will be furnished to specify on a geographical basis the storage point designation in relation to each range of water and aerial ports (such as, the west, gulf, and east coasts). In addition, canceling DoD Components will designate a contact point(s) to provide disposition instructions on material that does not meet the automatic diversion conditions specified in paragraph C4.7.25.10. Designated contact points will provide requested disposition instructions to DTS within 24 hours on material located at air terminals and within 48 hours on material located at water terminals.~~

~~C4.4.2.12. Single Line Item Cancellation. Customers retain the authority to submit single line item cancellation requests via DLMS 869C at any time before, during, or after the effective date of the mass cancellation.~~

[Intervening text not shown]

C4.7.25. ~~Processing Mass or Universal Cancellation Requests~~ **Reserved.**

~~C4.7.25.1. Sources of supply are responsible for ensuring that requisition processing, procurement, and storage activities exercise the fullest practical resourcefulness in preventing the issue and shipment of unwanted material. The practical considerations involved in the processing of cancellation requests include such factors as time, packing and handling, related costs, and the location of material for which cancellation is requested.~~

~~C4.7.25.2. Sources of supply in receipt of mass or universal cancellation requests will cancel quantities for which MROs, and/or purchase requests have not been submitted to storage or procurement activities. Provide a DLMS 870S, with Status Code BQ or B4, as appropriate, as notice of accomplished cancellations to all authorized status organizations within the timeframe for sending status.~~

~~C4.7.25.3. Sources of supply will send a DLMS 870S with Status Code B9 to all authorized status organizations under Chapter 5 within the timeframes for sending status for:~~

~~C4.7.25.3.1. Unconfirmed MROs and open procurement actions.~~

~~C4.7.25.3.2. MROs that indicate shipment to OCONUS activities within 45 calendar days of the effective date of the mass cancellation.~~

~~C4.7.25.4. Provide a DLMS 870S with Status Code BQ, B4, or B6 as notification for each line item actually canceled or diverted and Status Code B8 for each line item not canceled or diverted.~~

~~C4.7.25.5. Sources of supply will provide storage activities cancellation requests, DLMS 940R, for all unconfirmed MROs and MRCs that indicate shipment to OCONUS activities within 45 calendar days of the effective date of the mass or universal cancellation.~~

~~C4.7.25.6. Sources of supply will provide procurement activities cancellation requests, DLMS 869C, for all open procurement actions.~~

~~C4.7.25.7. Sources of supply will not provide storage and procurement activities with cancellation requests when:~~

~~C4.7.25.7.1. In receipt of MRCs that show shipment has been accomplished by parcel post.~~

~~C4.7.25.7.2. In receipt of MRCs that show shipment to CONUS activities has been accomplished.~~

~~C4.7.25.7.3. In receipt of MRCs that show shipment to OCONUS customers was accomplished more than 45 calendar days prior to the receipt of the mass or universal cancellation request.~~

~~C4.7.25.8. The following rules apply to mass or universal cancellation of shipments from storage:~~

~~C4.7.25.8.1. Upon receipt of the mass or universal cancellation DLMS 869C pending the receipt of single line item cancellation requests DLMS 940R from the source of supply, the storage activity will identify all affected MROs where the items have not been released to a carrier for delivery to the consignee.~~

~~C4.7.25.8.2. For universal cancellation, the storage activity will suspend further processing of all MROs, including any containing Special Requirements Code 555.~~

~~C4.7.25.8.3. For those OCONUS shipments that meet the mass or universal cancellation criteria and have entered the DTS within 45 calendar days of the date of the mass or universal cancellation request, the storage activity will generate a DLMS 945A with Transaction Type Code NR in the WO6 segment and Status Code DW in the LQ segment.~~

~~C4.7.25.8.4. Storage activities will accomplish cancellation for all items for which single line item cancellation requests, DLMS 940R with Transaction Type Code ND, are received from the source of supply and the items have not been released to a carrier for delivery to the consignee.~~

~~C4.7.25.8.5. Storage activities will advise the source of supply of their actions taken in response to cancellation requests. When a shipment has not been released to the~~

~~carrier for delivery to consignee and cancellation is accomplished, DLMS 945A will be prepared and sent to the source of supply with Status Code BQ.~~

~~C4.7.25.8.6. When storage activities do not accomplish cancellation, the source of supply will be furnished DLMS 945A with Status Code B8.~~

~~C4.7.25.8.7. Storage activities in receipt of transportation confirmation of shipment diversion transactions will send to the appropriate source of supply a materiel release advice with Status Code BQ, for requisitions contained within the shipment unit. The materiel release advice in this instance will contain, in addition to the normal data elements, the identification of the new consignee.~~

~~C4.7.25.8.8. Storage activities in receipt of transportation denial of shipment diversion transactions will send to the appropriate source of supply a materiel release advice with Status Code B8.~~

~~C4.7.25.9. All rules governing single line item cancellation of shipments from procurement also apply to requests for mass or universal cancellation, except as modified herein:~~

~~C4.7.25.9.1. The source of supply will initiate cancellation requests for all items scheduled for direct delivery, and for which purchase requests have been submitted, regardless of materiel costs.~~

~~C4.7.25.9.2. Procurement activities will not initiate actions with the DTS to cause diversion of shipments at terminals.~~

~~C4.7.25.9.3. For those OCONUS shipments that have entered the DTS within 45 calendar days of the date of the mass or universal cancellation request, or from the date of receipt of the DLMS 869C from the source of supply, the procurement activity will send a DLMS 945A with Action Code AW in the W06 segment to the DLA Transaction Services.~~

~~C4.7.25.9.4. Procurement activities in receipt of confirmation of shipment diversion transactions will send to the appropriate source of supply a DLMS 945A with Status Code BQ for requisitions contained within the shipment unit. The DLMS 945A in this instance will contain, in addition to the normal data elements, the DoDAAC of the new consignee.~~

~~C4.7.25.9.5. Procurement activities in receipt of denial of shipment diversion transactions will send, to the appropriate source of supply, a DLMS 945A with Status Code B8.~~

~~C4.7.25.10. Disposition of Frustrated Shipments and/or Materiel from Mass/Universal Cancellation Actions~~

~~C4.7.25.10.1. The disposition of frustrated shipments at WPOEs/APOEs that are the result of mass or universal cancellation action will be as follows:~~

~~C4.7.25.10.1.1. Shipments from DoD storage activities, or from commercial vendors acting under the direction of a DoD procuring activity, will be diverted to the predesignated storage sites of the shipping/procuring DoD Component.~~

~~C4.7.25.10.1.2. Shipments from GSA storage points, or from commercial vendors acting under the direction of a GSA procuring activity, will be diverted to predesignated GSA materiel returns facilities.~~

~~C4.7.25.10.1.3. DTS attempts to divert/frustrate shipments will terminate 45 calendar days from the effective date of the mass or universal cancellation message.~~

~~C4.7.25.10.2. Certain strategic and tactical operations or political considerations may dictate that all shipments for a given consignee be stopped or diverted. In those most restrictive of shipment diversion situations, economic considerations, such as, the comparison of accessorial cost of stopping, holding, and returning the materiel to storage activities, the value of the canceled materiel, and the costs of the receiving activity to perform the necessary processing or reprocessing of the materiel are not controlling factors. In most situations, however, the strategic, tactical, or political environment is such that complete disregard of these economic considerations is not warranted.~~

~~C4.7.25.10.3. Transportation diversion procedures are established to permit diversion only if the materiel being shipped can be identified and located by TCN.~~

~~C4.7.25.10.3.1. Non Consolidated Shipment Units. Shipment units eligible for cancellation that have not been consolidated into a container with other shipments will be stopped and diverted by the POE up to the point of lift. Diversion or cancellation eligible shipments at or beyond the POD will be the responsibility of the appropriate theater, force, logistics, or type commander.~~

~~C4.7.25.10.3.2. Consolidated Multiple Shipment Units. Individual line items will not be removed from multiple line shipment units (consolidated packs), nor will a shipment unit container be removed from a multi container shipment (SEAVAN) type device. Shipment units cannot be diverted in the DTS if stuffed or loaded with other shipment units or on multiple shipment unit devices; such as, SEAVANS, container express (CONEX), MILVANS (Military Van), and Aircraft 463LPallets.~~

~~C4.7.25.10.4. For those mass or universal cancellation requests that specify FSC, FSG, NSN, or part number data, the DTS will stop and frustrate, for the DoD Component review, all shipments of the canceling DoD Component for the affected consignees. Disposition of cancellation eligible shipments at or beyond the POD will be the responsibility of the appropriate theater, force, logistics, or type commander.~~

~~C4.7.25.10.5. DTS will generate specified documentation for the following categories of shipments:~~

~~C4.7.25.10.5.1. For all shipments that are diverted, as a result of mass or universal cancellation, DTS will generate a confirmation of shipment diversion transaction to DAAS. The confirmation of shipment diversion must contain complete transportation~~

movement and control document (TCMD) data for each shipment unit and, if available, the contract number. In addition:

~~C4.7.25.10.5.1.1. For shipments diverted under pre-positioned instructions, DTS will send a BL to the new consignee.~~

~~C4.7.25.10.5.1.2. For shipment units frustrated but not diverted to a specific site, DTS will send a request for disposition instructions to DAAS, that will route the transactions to the appropriate DoD Component contact points. In situations where the designated DoD Component contact point is a collocated liaison office, the request for disposition instruction transactions will be listed and provided to the contact point directly. After receipt of disposition instructions for such frustrated shipments, DTS will prepare a BL or other appropriate transaction for the new consignee.~~

~~C4.7.25.10.5.1.3. For shipments in transit to, at, or between POD and OCONUS consignee, OCONUS DTS activities will request disposition instructions from the appropriate theater, force, logistics, or type commander's designated contact point.~~

~~C4.7.25.10.5.2. For shipments in transit between WPOE/APOE and OCONUS consignees less than 30 calendar days, DTS will:~~

~~C4.7.25.10.5.2.1. Generate a listing of the manifest shipment unit data, vessel/aircraft identification, and departure date, water port of debarkation (WPOD)/aerial port of debarkation (APOD), and estimated time of arrival (ETA). This listing will be sent to the affected OCONUS command component, the appropriate WPOD/APOD, and to the designated contact point, if requested.~~

~~C4.7.25.10.5.2.2. Send denial or shipment diversion transactions for each individual shipment unit to DAAS.~~

~~C4.7.25.10.6. Storage sites in receipt of diverted shipments will report the receipt to the appropriate source of supply under Chapter 13. Reconsignment/ disposition will be as directed.~~

~~C4.7.25.10.7. The DoD Component initiating cancellation requests applicable to U.S. Forces requisitions will be charged with: (1) transportation and terminal costs associated with holding, stopping, and returning materiel to storage; (2) procurement termination costs when it is determined that termination is in the best interest of the Government; and (3) excess transportation costs that may be incurred when moving cargo unaffected by the mass or universal cancellation action. Specific instructions concerning materiel transportation charges and credit allowances are contained in the [DoD 7000.14-R](#), [DoD 4140.1-R](#), [FPMR 101-26.311](#), and [FPMR 101-27.505](#).~~

C4.7.26. Processing of Mass or Universal Cancellation Transactions by DAAS

Reserved.

~~C4.7.26.1. Upon receipt of the mass or universal cancellation request, DLA Transaction Services will begin the establishment of a transportation to supply documentation correlation (TSDC) file. DLA Transaction Services will add to the TSDC file a copy of each DLMS 945A that has Transaction Type Code NR in the WO6 segment and Status Code DW in the LQ segment.~~

~~C4.7.26.2. When a confirmation of shipment diversion transaction is received from the DTS, DAAS will match the TCN with the TCN in all applicable DLMS 945A transactions in the TSDC file. DAAS will send a DLMS 870S with Status Code B6 to the applicable source of supply for each materiel release advice transaction matched. In this instance, the supply status transaction will contain the DoDAAC of the new consignee.~~

~~C4.7.26.3. When a denial of shipment diversion transaction is received from DTS, DAAS will match the TCN with the TCN in all applicable materiel release advice transactions in the TSDC file. DAAS will send DLMS 870S with Status Code B8 to the applicable source of supply for each materiel release advice matched.~~

~~C4.7.26.4. When a request for disposition instructions is received from DTS, DAAS will match the TCN with the TCN in all applicable materiel release advice transactions in the TSDC file. DAAS will send a narrative message to the designated canceling DoD Component contact point that provides the contact point with the TCMD transaction data, plus all supporting materiel release advice transactions that comprise the shipment.~~

~~C4.7.26.5. For those materiel release advice transactions on which confirmation/denial shipment diversion, or request for disposition instruction transactions are not received within 21 calendar days of the date of the mass or universal cancellation request, DAAS will initiate a shipment tracer action under [DTR 4500.9-R](#), "Defense Transportation Regulation," to the APOE/WPOE indicated in the materiel release advice.~~

~~C4.7.26.6. When confirmation/denial of diversion or request for disposition instruction transactions are received from the transportation clearance authorities and DAAS does not find a corresponding materiel release advice record within the TSDC file, DAAS will forward DLMS 870S transactions to the shipping activity identified in the transportation mass/universal cancellation status transactions~~

[Intervening text not shown]

Enclosure 3

- A. Update Chapter 8 to DLM 4000.25-1 to align with the new Chapter 27 in DLM 4000.25, Volume 2. Removed text is identified by ~~double-strikethroughs~~. New text is annotated with *red, bold, italics*.

C8. CHAPTER 8
MASS OR UNIVERSAL CANCELLATION OF
REQUISITIONS

C8.1. **GENERAL**

C8.1.1. Purpose. This chapter provides procedures for the request, generation, submission, and processing of mass and universal cancellations of requisitions. It also provides procedures for the disposition of frustrated shipments and materiel resulting from mass and universal cancellation actions.

C8.1.2. Transactions

C8.1.2.1. Request for Mass Cancellation of Requisitions Transaction is identified by the MILSTRIP Mass Cancellation Message (See Appendix 1.23). There is no MILSTRIP legacy DIC equivalent.

C8.1.2.2. Request for Universal Cancellation of Requisitions Transaction is identified by the MILSTRIP Universal Cancellation Message (See Appendix 1.23). There is no MILSTRIP legacy DIC equivalent.

C8.1.2.3. Requisition Modification Transaction is identified by DIC AM1, AM2, AM4, AM5, AMA, AMB, AMD, and AME.

C8.1.2.4. Materiel Release Order Modification Transaction is identified by DIC AM1, AM2, AM4, AM5, AMA, AMB, AMD, and AME from the source of supply (SoS) to the storage activity.

C8.1.2.5. Disposal Release Order Modification Transaction is identified by the MILSTRIP legacy DIC AMJ.

C8.1.2.6. Inventory Control Point Requisition Modification Transaction is identified by DIC AMP.

C8.1.2.7. Universal Requisition Cancellation to Storage Activity Transaction is identified by DIC AC7.

C8.1.2.8. Universal Requisition Cancellation to Procurement Activity Transaction is identified by DIC ACM.

C8.1.2.9. Mass Requisition Cancellation to Storage Activity Transaction is identified by DIC AC6.

C8.1.2.10. Mass Requisition Cancellation to Procurement Activity Transaction is identified by DIC ACP.

C8.1.2.11. Reserved.

C8.1.2.12. The Supply Status Transactions are identified as follows:

C8.1.2.12.1. Response to Requisition - DIC AE1, AE2, AE3, AE8, AE9, AEA, AEB, AED, and AEE.

C8.1.2.12.2. Notice of Response to Direct Vendor Delivery - DIC AB1, AB2, AB3, and AB8.

C8.1.2.13. The Reply to Cancellation Request – Shipment Status is identified by DIC AU1, AU2, AU3, AU4, AU5, AU8.

C8.1.2.14. The Reply to Cancellation Request – Materiel Release Confirmation is identified by DIC AU0, AUA, and AUB.

C8.1.2.15. The Reply to Cancellation Request is identified by DIC AG6.

C8.1.2.16. The Storage Activity Supply Status is identified by DIC AE6.

C8.2. Applicability

C8.2.1. Events such as base closures, termination of special projects, ship and unit inactivations, termination of agreements, and termination of vessel outfitting or construction can necessitate the requirement for mass or universal cancellation.

C8.2.2. Although these events may ultimately require mass or universal cancellation action, they are normally known to the affected activities well in advance of the effective date of such closures or termination action. In these instances, every effort ***will*** be made by the requisitioning activity to minimize the continued processing of requisitions by the ***sources of supply (SoS)***, and the subsequent entry of unwanted shipments into the Defense Transportation System (DTS), through initiation and processing of single line-item cancellations (See Chapters 2 and 3).

C8.2.3. When a total project (or total requirement for a single base) is no longer required and should be canceled and it is known that insufficient time remains to permit continued cancellation on a single line basis, a mass cancellation or universal cancellation request ***may be initiated***.

C8.2.3.1. A mass cancellation permits continued supply action and shipment processing for selected requisitions.

C8.2.3.2. A universal cancellation serves to terminate all such processing, even requisitions previously identified for continued supply action and shipment processing under mass cancellation situations.

C8.2.3.3. ~~Normally the request will specify either mass or universal cancellation;~~ but, **Under** extreme conditions, a mass cancellation may be superseded by a universal cancellation.

C8.2.4. Requisitions **that require** continued supply action and shipment processing under mass cancellation situations **must** be **identified** by the requiring activity at the earliest date through submission of a Requisition Modification (**DIC AM_**) **citing Special Requirements Code 555**⁷.

C8.2.4.1. The requisition may not be **modified** to **cite Special Requirements Code 555** after the effective date of the requested mass cancellation; however, **requisition modifications** submitted to change other data elements when the **Special Requirements Code 555 was** previously entered must perpetuate the **Special Requirements Code 555**.⁸

C8.2.4.2. Requisitions containing, or modified to contain, **Special Requirement Code 555 will** receive processing precedence under Chapter C3.

C8.2.5. When a universal cancellation is initiated to supersede a mass cancellation and there are outstanding requisitions or **requisition modifications citing Special Requirements Code 555**, **the SoS will** provide **a Universal Requisition Cancellation to Storage Activity (DIC AC7) or a Universal Requisition Cancellation to Procurement Activity (DIC ACM)** for all outstanding requisitions, regardless of the **presence of a Special Requirements Code 555**.

C8.3. **INITIATION OF MASS OR UNIVERSAL CANCELLATION OF REQUISITIONS**

C8.3.1. **Only designated personnel within an organization may initiate** requests for mass or universal cancellation of requisitions ~~will be initiated by the DoD Component headquarters, or by an authorized command element. The DoD Component contact points established for issuance and receipt of requests for mass and universal cancellation are listed on the DLA Logistics Management Standards Website www.dla.mil/j-6/dlmso/OLibrary/servicopoints/default.asp.~~ **If there are any questions regarding the authenticity of a mass/universal cancellation, contact either the Component Supply PRC Representative or the customer support representative for the source of supply. Component Supply PRC Representatives are identified on the DLMSO Website at <https://www2.dla.mil/j-6/dlmso/CertAccess/SvcPointsPOC/allpoc.asp>.** The preparation of a mass or universal cancellation request **will** be accomplished **by preparation of the DLMS 869C or under the message** format reflected in Appendix AP1.23.

⁷ Code 555 identified in the required delivery date field for MILSTRIP legacy transactions.

⁸ Revised requisition modifier procedures last reported as not implemented by U.S. Marine Corps (USMC). Refer to Approved MILSTRIP Change Letter (AMCL) 123C.

C8.3.1.1. Inter-Component dissemination of requests for mass or universal cancellation **must** be **coordinated in advance to determine if the DLMS 869C or message format will be used. If using the message format, the requesting Component must identify the authorized recipient from the Component to process the mass or universal cancellation. If it is not known, contact the Component's Supply PRC representative or the customer support representative for the source of supply to identify the point of contact** made by the contact points designated in Column 1 to the designated contact points identified in Column 2 of the Mass or Universal Cancellation Webpage on the DLA Logistics Management Standards Website www.dla.mil/j-6/dlmsc/eLibrary/servicetypes/default.asp.

C8.3.1.2. Intra-Component dissemination of requests for mass or universal cancellations must be performed by the **authorized** Component contact point designated in Column 2 of the Mass or Universal Cancellation Webpage on the DLA Logistics Management Standards Website www.dla.mil/j-6/dlmsc/eLibrary/servicetypes/default.asp. Intra-Component dissemination **will** include all Component supply sources, storage sites, and other activities within the DoD Component processing **MILSTRIP** documentation or shipments with capability to cancel requisitions or divert shipments. In addition, the designated Component contact points **must** ensure that the appropriate overseas theater, force, logistics, or type commanders are cognizant of mass or universal cancellation actions affecting their areas of responsibility.

C8.3.2. Due to the requirement to ensure that mass/universal cancellation requests are only initiated by authorized personnel, these cancellations must not be initiated through use of DOD EMALL, or its replacement system FEDMALL.

C8.3.3. Required Data Content. Requests for mass or universal cancellation action **will** be submitted to the Component designated contact point(s) by message (Appendix AP1-23) **applicable SoS** for cancellation of all open requisitions applicable to specific projects, or bases (as identified by activity address codes (AAC)). The request for mass or universal cancellations **will** contain identification of the activity having **submitting** the request, the effective date, and the required codes for identification of one of the following, for which cancellation of all applicable requisitions is requested:

C8.3.3.1. **One** project code and **one** ship-to address (requisitioner, rp 30-35 or supplementary address (SUPADD), rp 45-50) **DoDAAC**.

C8.3.3.2. No project code and **one** ship-to address (requisitioner, rp 30-35 or SUPADD, rp 45-50) **DoDAAC**

C8.3.3.3. One project code and various addresses **multiple ship-to DoDAACs**

C8.3.3.4. No project code and various addresses **multiple ship-to DoDAACs**

C8.3.3.5. Various **Multiple** project codes and one various addresses **ship-to DoDAAC**

C8.3.3.6. Federal supply classification (FSC), ~~Federal supply group (FSG),~~ national stock number (NSN), **local stock number (LSN)**, or **CAGE/**part number when associated with the address of the original requisition document number ship-to address and/or project **code** designator.

C8.3.4. Customers retain the authority to submit single line-**item** cancellation requests (DICs AC1, AC2, and AC3) at any time before, during, or after the mass cancellation effective date.

C8.4. **CONTINUING HIGH PRIORITY DEMANDS DURING A MASS CANCELLATION**

C8.4.1. A need may exist to continue the processing of certain requisitions and shipments during mass cancellations such as high priority demands to satisfy not mission capable supply (NMCS) conditions (identified by **Special Requirements Code 999** or ~~N in rp 62 of the requisition~~). In addition, a need may exist to allow continued processing ~~on~~ **of** requisitions for materiel required to effect base closure. In these instances, **submit a requisition modification citing Special Requirements Code 555 to the SoS prior to the submission of the mass cancellation request. Sources of supply will not cancel requisitions that have been modified to contain Special Requirements Code 555 during a mass cancellation process.** ~~the mass cancellation request shall specify~~ **If submitting the mass cancellation request via offline message, then cite** one of the following selective criteria in the special instructions segment **of the message**:

C8.4.1.1. Project code(s) when associated with the ship-to address ~~(requisitioner, rp 30-35 or SUPADD, rp 45-50)~~ **DoDAAC** being canceled

C8.4.1.2. **Special Requirements Code 999 or N** ~~NMCS RDD entry (rp 62-64)~~ when associated with the ship-to address ~~(requisitioner, rp 30-35 or SUPADD, rp 45-50)~~ **DoDAAC** being canceled

C8.4.1.3. FSC, ~~FSG,~~ NSN, or **CAGE/**part number when associated with the ship-to address ~~(requisitioner, rp 30-35 or SUPADD, rp 45-50)~~ **DoDAAC** being canceled

C8.4.1.4. Specific requisition document number(s) and routing identifier code (RIC) ~~-From~~ the status received or the RIC ~~-To~~ which the requisition has been transmitted if status has not been received

C8.4.1.5. Specific priority designator (PD) when associated with the ship-to address ~~(requisitioner, rp 30-35 or SUPADD, rp 45-50)~~ **DoDAAC** being canceled

C8.4.1.6. Required delivery period (RDP) ~~entry (rp 62-64)~~ when associated with the ship-to address ~~(requisitioner, rp 30-35 or SUPADD, 45-50)~~ **DoDAAC** being canceled - conventional ammunition only⁹

⁹ Use of RDP for conventional ammunition last reported as not implemented by U.S. Air Force (USAF). Refer to AMCL 148.

~~C8.4.2. Upon implementation of the mass cancellation message, sources of supply and storage activities shall review all prospective cancellations to identify those for which continued processing has been requested under Paragraph C8.1.5. above. In the case of items scheduled for direct delivery, the supply source shall forward DIC AMP requisitions modifiers to procurement sources.~~

~~C8.4.3. Supply sources, storage activities, and procurement sources annotate the affected requisition(s) and all associated transactions/records, with an expedited handling signal 555 in the RDD/RDP data field.~~

C8.4.2. Upon receipt of Requisition Modifications citing continued processing action during a mass cancellation, SoS Supply sources, storage activities, and procurement sources **must** annotate the affected requisition(s) and all associated transactions/records, with an expedited handling signal **Special Requirements Code 555** in the RDD/RDP¹⁰ data field.

C8.4.3. Upon receipt of either the Requisition Modification citing Special Requirements Code 555 or the offline Mass Cancellation message citing selective criteria for continued processing action in the special instructions segment implementation of the mass cancellation message, sources of supply **the SoS** and storage activities shall **must** review all prospective cancellations to identify those for which continued processing has been requested under Paragraph C8.1.5. above. **For continued processing of requisitions at storage activities, the SoS will pass the Requisition Modification to the Storage Activity.** In the case of items scheduled for direct **vendor** delivery, the supply source shall **SoS must** forward **ICP Requisition Modifications (DIC AMP)** requisitions modifiers to procurement sources.

C8.4.4. The Defense Transportation System (DTS) shall will continue movement of materiel to which an RDD of **Special Requirements Code 555** has been applied except when a universal cancellation has been announced.

~~C8.1.8. When outside the continental U.S. (OCONUS) shipments have already departed from continental U.S. (CONUS) ports, the responsibility for diversion or disposition is that of the consignee or the appropriate theater, force, logistics, or type commander. Notice to the latter shall be the transportation lift data provided by the DTS clearance authority. (See Paragraph C8.5.4.)~~

~~C8.1.9. No attempt shall be made to divert materiel destined to CONUS customer activities beyond the point of shipment.~~

~~C8.1.10. All shipping Components shall designate storage points within their distribution system to receive shipments that have been redirected as a result of mass or universal cancellation. Fund citations for bill of lading (BL) preparation shall also be provided. These designated points and fund citations shall be provided to Air Mobility Command (AMC), Military Surface Deployment and Distribution Command (SDDC), or theater commanders and shall serve as predesignated consignees for any announced mass or universal cancellation.~~

¹⁰ Ibid.

~~If more than one storage point is designated, instructions shall be furnished to specify on a geographical basis the storage point designation in relation to each range of water and aerial ports (e.g., west, gulf, and east coasts). In addition, canceling Components shall designate a contact point(s) to provide disposition instructions on materiel that does not meet the automatic diversion conditions specified in Paragraph C8.5. Designated contact points shall provide requested disposition instructions to DTS within 24 hours on materiel located at air terminals and within 48 hours on materiel located at water terminals.~~

~~C8.2. RESERVED~~

C8.5. SOURCE OF SUPPLY PROCESSING MASS OR UNIVERSAL CANCELLATION REQUESTS

C8.5.1. Sources of supply are responsible for ~~assuring~~ **ensuring** that requisition processing, procurement, and storage activities exercise the fullest practical resourcefulness in preventing the issue and shipment of unwanted materiel. The practical considerations involved in the processing of cancellation requests include such factors as time, packing and handling, related costs, and location of materiel for which cancellation is requested.

C8.5.2. ~~Sources of supply shall~~ **The SoS must** cancel all requisitions dated on or prior to the effective date announced in mass or universal cancellation requests for which materiel release orders (MROs), ~~DD Form 1348-1A, "Issue Release/Receipt Document,"~~ **and/or** purchase requests have not been submitted to storage or procurement activities. **Provide a Supply Status transaction citing Status Code** ~~Notice of completed cancellations shall be provided by BQ or B4 supply status (DIC AE), as appropriate,~~ **as notice of accomplished cancellations** ~~and transmitted to all eligible status recipients under Chapter 4 and within the timeframe for furnishing status.~~

C8.5.3. ~~Supply sources shall~~ **The SoS will** furnish supply status **transactions (DIC AE)** ~~containing~~ **citing** Status Code B9 to all eligible recipients under Chapter ~~C4~~ **and** within the timeframes for furnishing status for:

C8.5.3.1. Unconfirmed **cancellation of open** MROs, ~~DD Form 1348-1A,~~ **and open procurement actions** ~~DIC ACMs.~~

C8.5.3.2. Materiel release confirmations (MRCs) **that indicate** ~~that~~ shipment to OCONUS activities ~~has been accomplished~~ within 45 days of the effective date of the mass cancellation.

C8.5.4. **Provide subsequent Supply Status transactions citing Status Codes BQ, B4, or B6 as notification** ~~Subsequent notice of cancellation or diversions actually accomplished as a result of mass or universal cancellation shall be in the format of supply status (DIC AE) containing Status Code BQ, B4, or B6 for each line item canceled/ or diverted. Cite Supply status (DIC AE) containing Status Code B8 shall be furnished to all eligible recipients for each line item that was neither~~ **not** canceled ~~nor~~ **or** diverted.

C8.5.5. **The SoS will** ~~Supply sources shall~~ provide storage and procurement activities with **mass requisition** cancellation requests **transactions (DIC AC6)** ~~AC6 for mass~~

~~cancellation and **universal requisition cancellation transactions** (DICs AC7/ACM for universal cancellations) for all unconfirmed MROs, purchase requests, and MRCs that indicate that shipment to OCONUS activities has been made within 45 days of the effective date of the mass or universal cancellation. These transactions are mandatory when MROs/purchase requests have been issued to another Component.~~

C8.5.6. The SoS will provide procurement activities with mass requisition cancellation transactions (DIC ACP) and universal requisition cancellation transactions (DIC ACM) for all open procurement actions. These transactions are mandatory when MROs/purchase requests have been issued to another Component. **If processed within an integrated Component system, equivalent internal transactions may be used.**

~~C8.5.7. The SoS Supply sources shall~~ **will** not provide storage and procurement activities with cancellation requests when:

~~C8.5.7.1. in receipt of MRCs providing evidence that~~ **show** shipment has been accomplished by parcel post (**USPS**),

~~C8.5.7.2. in receipt of MRCs providing evidence that~~ **show** shipment to CONUS activities has been accomplished, and

~~C8.5.7.3. in receipt of MRCs providing evidence that~~ **show** shipment to OCONUS customers was accomplished more than 45 days prior to the receipt of the mass or universal cancellation request.

C8.5.8. The SoS will follow-up with the procurement or storage activity, as applicable, via offline means (e.g., email, phone) (there is no MILSTRIP legacy equivalent) when no response to the original universal or mass requisition cancellation request has been received within three days.

C8.6. STORAGE ACTIVITY PROCESSING OF MASS OR UNIVERSAL REQUISITION CANCELLATIONS ~~The following rules apply to mass or universal cancellation of shipments from storage:~~

~~C8.6.1. Upon receipt of the mass or universal requisition cancellation transaction(s) request pending the receipt of single line cancellation requests from the SoS supply source, the storage activity shall~~ **will** identify all affected MROs where the items have not been released to a carrier for delivery to the consignee.

~~C8.6.1.1. For mass cancellation, the storage activity shall~~ **will** not suspend processing of MROs identified for continued processing under **paragraph C8.4.**

~~C8.6.1.2. For universal cancellation, the storage activity shall~~ **will** suspend further processing of all MROs, including any containing an RDD of **citing Special Requirements Code 555.**

C8.6.2. For **CONUS shipments**, storage activities shall perform **will accomplish** cancellation for all items for which single line **mass or universal requisition** cancellation requests **transactions** are received from the source of supply **SoS** and the items have not been released to a carrier for delivery to the consignee.

C8.6.3. Storage activities shall **will** advise the source of supply **SoS** of their actions taken in response to cancellation requests. When a shipment has not been released to the carrier for delivery to consignee and cancellation is accomplished, **the storage activity will** ~~advise to the source of supply shall be prepared~~ **send the SoS a Reply to Cancellation Request transaction (DIC AG6) citing Status Code BQ.** ~~in the same format as the cancellation request, with the exception that rp 4-6 shall contain the RIC of the source of supply to which the transaction shall be directed and rp 67-69 shall contain the RIC of the activity preparing the transaction. The transaction shall contain DIC AG6. (See Appendix AP3.8.)~~

C8.6.4. For shipments already released to a carrier for delivery to the consignee not meeting the criteria stipulated in paragraph C8.5.7. , the storage activity will generate a Reply to Cancellation Request – Shipment Status (DLMS 856S/DIC AU_) for routing by DLA Transaction Services under standard MILSTRIP procedures for shipment status. It will also generate the Storage Activity Supply Status (DLMS 945A/DIC AE6) to the SoS.

C8.6.4.1. For **CONUS shipments and those** OCONUS shipments that meet the mass or universal cancellation criteria and ~~that~~ have entered the DTS within 45 **calendar** days of the date of the mass or universal **requisition** cancellation request, the storage activity shall **will generate the Reply to Cancellation Request – Shipment Status (DIC AU_).** ~~generate a shipment status transaction (DIC AU7) to the Defense Automatic Addressing System (DAAS). The DIC AU7 shall be prepared in the same format as a DIC AU1 transaction.~~

C8.6.4.2. The Storage Activity Supply Status transaction to the SoS will cite Status Code B9 indicating that action is being taken to cancel/divert the shipment.

C8.6.5. When storage activities do not accomplish cancellation, the source of supply shall **will** be furnished **a Storage Activity Supply Status transaction (DIC AE6),** reflecting **citing** Status Code B8.

C8.6.6. Storage activities in receipt of transportation confirmation of shipment diversion transactions shall generate a DIC AG6 **will send** to the appropriate source of supply **SoS a Reply to Cancellation Request transaction (DIC AG6) citing Status Code B6** for each requisition contained within the shipment unit. **The transaction will also cite** ~~In addition to the normal data elements, the DIC AG6 in this instance shall contain the DoD activity address code (DoDAAC) of the new consignee in rp 45-50.~~

C8.6.7. Storage activities in receipt of transportation denial of shipment diversion transactions shall **will** generate a **Reply to Cancellation Request – Materiel Release Confirmation (DIC AU0/AUA/AUB** to the appropriate source of supply. This transaction shall **will** be prepared under Appendix AP3.14.

C8.6.8. Upon receipt of a follow-up request, the storage activity will respond with the appropriate transaction as outlined in the preceding procedures for storage activity processing of these cancellation requests.

C8.7. DIRECT VENDOR DELIVERY PROCESSING OF MASS OR UNIVERSAL REQUISITION CANCELLATIONS

C8.7.1. All rules governing the single-line cancellation of shipments from procurement ~~under Chapter 3~~ also apply to requests for mass or universal **requisition** cancellation, except as modified herein. Where DIC transactions are identified for exchange of reporting events between the SoS and the procurement activity, internal system or offline communications (e.g., email, phone), are authorized when procurement systems are not capable of supporting the MILSTRIP transactions.

C8.7.2. ~~The source of supply shall~~ **SoS will** initiate **universal requisition** cancellation requests ~~transactions (DIC ACP/ACM) and mass requisition cancellation transactions (DIC ACP)~~ for all items scheduled for direct delivery, and for which purchase requests have been submitted, regardless of materiel costs, unless continued processing has been requested under **paragraph C8.4.**

C8.7.2.1. Mass cancellation ~~shall~~ **will** not be requested for requisitions ~~annotated with an RDD of~~ **citing Special Requirements Code 555.**

C8.7.2.2. Universal cancellation ~~shall~~ **will** be requested regardless of the entry in the ~~RDD~~ **Special Requirements** field.

C8.7.3. Procurement activities will advise the SoS of actions taken in response to cancellation requests. When a shipment has not been released to the carrier for delivery to consignee and cancellation is accomplished, the procurement activity will send the SoS a Reply to Cancellation Request transaction (DIC AG6) citing Status Code BQ or B4. Procurement activities ~~shall~~ **will** not initiate actions with the DTS to cause diversion of shipments at terminals.

C8.7.4. For shipments already released to a carrier for delivery to the consignee not meeting the criteria stipulated in paragraph C8.5.7., the procurement activity will generate the Storage Activity Supply Status (DIC AE6) to the SoS. The SoS will generate, on behalf of the procurement activity, a Reply to Cancellation Request – Shipment Status (DIC AU_) for routing by DLA Transaction Services under standard MILSTRIP procedures for shipment status.

C8.7.4.1. Reserved. ~~For OCONUS shipments that have entered the DTS within 45 days of the date of the mass or universal cancellation request, or from the date of receipt of the DIC ACP/ACM) from the supply source, the procurement activity shall generate a shipment status transaction (DIC AU7) to DAAS. The DIC AU7 shall be prepared in the same format as the DIC AU1 transaction.~~

C8.7.4.2. The Storage Activity Supply Status transaction to the SoS will cite Status Code B9 indicating that action is being taken to cancel/divert the shipment.

This status will be perpetuated by the SoS in a Supply Status transaction to the requesting activity.

C8.7.5. Procurement activities in receipt of confirmation of shipment diversion transactions ~~shall will generate~~ ***send to the appropriate SoS a Reply to Cancellation Request transaction (DIC AG6)*** to the appropriate source of supply ***SoS citing Status Code B6*** for each requisition contained within the shipment unit. ~~The DIC AG6 in this instance shall be prepared from the data available in the original DIC ACP/ACM, or purchase request, except that it shall contain the DIC AG6 and indicate~~ ***The transaction will also cite the DoDAAC of the new consignee in rp 45-50.***

C8.7.6. Procurement activities in receipt of denial of shipment diversion transactions ~~shall generate a DIC AU shipment status~~ ***will send*** to the appropriate source of supply ***SoS a Reply to Cancellation Request – Materiel Release Confirmation transaction (DIC AU0/AUA/AUB).*** ~~This transaction shall be prepared using Appendix AP3.14.~~

C8.7.7. If the procurement activity is unable to transmit either the confirmation of shipment diversion or the denial of shipment diversion, it will be presented to the SoS via internal system communication or offline means (e.g., email, phone), at which time the SoS will update its records accordingly.

C8.7.8. Upon receipt of a follow-up request, the procurement activity will respond with the appropriate transaction or via offline means (e.g., email, phone) as outlined in the preceding procedures for procurement activity processing of these cancellation requests.

~~C8.4. RESERVED~~

C8.8. DTS PROCESSING OF MASS OR UNIVERSAL REQUISITION CANCELLATIONS

C8.8.1. Diverting Outside the Continental U.S. Shipments. When outside the continental U.S. (OCONUS) shipments have already departed from continental U.S. (CONUS) ports, the responsibility for diversion or disposition is that of the consignee or the appropriate theater, force, logistics, or type commander. Notice to the latter ~~shall will~~ be the transportation lift data provided by the DTS clearance authority. (See ***paragraph C8.9.4.***)

C8.8.2. Diverting Continental U.S. Shipments. No attempt ~~shall will~~ be made to divert materiel destined to CONUS customer activities beyond the point of shipment.

C8.8.3. Designated Storage Points. All shipping ***DoD*** Components ~~shall will~~ designate storage points within their distribution system to receive shipments ~~that have been~~ redirected as a result of mass or universal cancellation. Fund citations for bill of lading (BL) preparation ~~shall must~~ also be provided. These designated points and fund citations ~~shall will~~ be provided to Air Mobility Command (AMC), Military Surface Deployment and Distribution Command (SDDC), or theater commanders and ~~shall will~~ serve as predesignated consignees for any announced mass or universal cancellation. If more than one storage point is designated, instructions ~~shall will~~ be furnished to specify on a geographical basis the storage point designation in relation to each range of water and aerial

ports (e.g., west, gulf, and east coasts). In addition, canceling **DoD** Components ~~shall~~ **will** designate a contact point(s) to provide disposition instructions on materiel that does not meet the automatic diversion conditions specified in **paragraph C8.9**. Designated ~~contact points~~ **of contact shall will** provide requested disposition instructions to DTS within 24 hours on materiel located at air terminals and within 48 hours on materiel located at water terminals.

C8.9. DISPOSITION OF FRUSTRATED SHIPMENTS/MATERIEL

C8.9.1. The disposition of frustrated shipments at water ports of embarkation (WPOE)/aerial ports of embarkation (APOE) that are the result of mass or universal cancellation action ~~shall~~ **will** be as follows:

C8.9.1.1. Shipments from DoD storage points or from commercial vendors acting under the direction of a DoD procuring activity ~~shall~~ **will** be diverted to the predesignated storage sites of the shipping/procuring **DoD** Component.

C8.9.1.2. Shipments from General Services Administration (GSA) ~~storage points or from~~ commercial vendors acting under the direction of a GSA procuring activity ~~shall~~ **will** be **disposed under normal excess/surplus/donation procedures. The shipments will not be diverted to GSA facilities.**¹¹ ~~diverted to predesignated GSA materiel returns facilities.~~

C8.9.1.3. DTS attempts to divert/frustrate shipments ~~shall~~ **will** terminate 45 **calendar** days from the effective date of the mass or universal cancellation request.

C8.9.2. Certain strategic and tactical operations or political considerations may dictate that all shipments for a given consignee be stopped or diverted. In these most restrictive of shipment diversion situations and economic considerations (e.g., the comparison of accessorial cost of stopping, holding, and returning the materiel to ~~depots~~/storage activities), the value of the canceled materiel and the costs of the receiving activity to perform the necessary processing or reprocessing of the materiel are not controlling factors. In most situations; however, the strategic, tactical, or political environment is such that complete disregard of these economic considerations is not warranted.

C8.9.3. *Transportation diversion procedures are established to permit diversion only if the materiel being shipped can be identified and located by TCN.*

C8.9.3.1. Non-Consolidated Shipment Units. *Shipment units eligible for cancellation that have not been consolidated into a container with other shipments will be stopped and diverted by the port of embarkation (POE) up to the point of lift. Diversion of cancellation eligible shipments at or beyond the port of debarkation (POD) will be the responsibility of the appropriate theater, force, logistics, or type commander.*

C8.9.3.2. Consolidated Multiple Shipment Units. *Individual line-items will not be removed from multiple-line shipment units (consolidated packs), nor will a*

¹¹ Refer to ADC 1142, *Update to Remove General Services Administration (GSA) from MILSTRIP Materiel Returns Program (MRP)*

shipment unit container be removed from a multi-container shipment (SEAVAN) type device. Shipment units cannot be diverted in the DTS if stuffed or loaded with other shipment units or on multiple shipment unit devices; such as, SEAVANS, container express (CONEX), MILVANS (Military Van), and Aircraft 463L pallets.

C8.9.4. For mass or universal cancellation requests that specify FSC, ~~FSC~~, NSNs/**LSNs**, or part number data, the DTS ~~shall~~ **will** stop and frustrate, for **the DoD** Component review, all shipments of the canceling **DoD** Component for the affected consignees. Disposition of cancellation eligible shipments at or beyond the POD ~~shall~~ **will** be the responsibility of the appropriate theater, force, logistics, or type commander.

C8.9.5. The DTS ~~shall~~ **will** generate specified documentation for the following shipment categories:

C8.9.5.1. For all shipments that are diverted as a result of mass or universal cancellation, the DTS ~~shall~~ **will contact the shipper to generate a confirmation of shipment diversion transaction to DAAS**. The confirmation of shipment diversion ~~shall~~ **will** contain complete Transportation Control and Movement Document (TCMD) data for each shipment unit and, if available, the contract number. In addition:

C8.9.5.1.1. For shipments that are diverted under pre-positioned instructions, the DTS ~~shall~~ **will** generate appropriate DTR 4500.9R, "Defense Transportation Regulation" transactions to the new consignee.

C8.9.5.1.2. For shipment units that are frustrated **and were not diverted to a specific site**, the DTS ~~shall generate~~ **will send** a request for disposition instructions to DAAS, which ~~shall route the transactions to~~ the appropriate Component contact points. In situations where the designated **DoD** Component contact point is a collocated liaison office, the request for disposition instruction transactions ~~shall~~ **will** be listed and provided to the contact point directly. After receipt of disposition instructions for such frustrated shipments, the DTS ~~shall~~ **will** prepare appropriate [DTR](#) transactions for the new consignee.

C8.9.5.1.3. For shipments in transit to, at, or between the POD and the OCONUS consignee, ~~the OCONUS DTS activities shall~~ **will** request disposition instructions from the appropriate theater, force, logistics, or type commander's designated contact point.

C8.9.5.2. For shipments ~~that have been~~ in transit between the WPOE/APOE and the OCONUS consignee less than 30 days, the DTS ~~shall~~ **will generate** a listing of the manifest shipment unit data, vessel/aircraft identification and departure date, water ports of debarkation (WPOD)/aerial ports of debarkation (APOD) and estimated time of arrival (ETA). This listing ~~shall~~ **will** be disseminated **sent** to the affected OCONUS command component, the appropriate WPOD/APOD, and to the designated contact point, if requested.

~~C8.9.5.2.2. Generate denial or shipment diversion transaction for each individual shipment unit to DAAS.~~

C8.9.6. Storage sites in receipt of diverted shipments ~~shall~~ **will** report the receipt to the appropriate supply **SoS** under [DLM 4000.25-2](#) (MILSTRAP). Reconsignment/disposition ~~shall~~ **will** be as directed.

C8.9.7. Specific instructions concerning materiel transportation charges and credit allowances are contained in the [DoD 7000.14-R](#), "Department of Defense Financial Management Regulations (FMRS)," (Vol 11B), Federal Property Management Regulation ([FPMR](#)) [101-26.311](#), and [FPMR 101-27.505](#). The Component initiating the cancellation requests applicable to U.S. Forces requisitions ~~shall~~ **will** be charged with the following:

C8.9.7.1. Transportation and terminal costs associated with holding, stopping, and returning materiel to ~~depots~~/storage,

C8.9.7.2. Procurement termination costs when it is determined that termination is in the best interest of the Government, and

C8.9.7.3. Excess transportation costs that may be incurred when moving ~~the~~ cargo that is unaffected by the mass or universal cancellation action.

~~C8.6. PROCESSING OF MASS OR UNIVERSAL CANCELLATION TRANSACTIONS BY THE DEFENSE AUTOMATIC ADDRESSING SYSTEM~~

~~C8.6.1. Upon receipt of the mass or universal cancellation request, DAAS shall begin the establishment of a transportation to supply documentation correlation (TSDC) file. As the shipment status (DIC AU7) transactions are received from the storage activities, they shall be entered into the TSDC file.~~

~~C8.6.2. When a confirmation of shipment diversion transaction is received from the DTS, DAAS shall match the transportation control number (TCN) in all applicable DIC AU7 transactions in the TSDC file. DAAS shall generate a DIC AE9 with Status Code B6 for each DIC AU7 matched to the supply source indicated by the RIC in rp 4-6 of the DIC AU7. In this instance, the DIC AE9 shall contain the DoDAAC of the new consignee in rp 45-50.~~

~~C8.6.3. When a denial of shipment diversion transaction is received from the DTS, DAAS shall match the TCN with the TCN in all applicable DIC AU7 transactions in the TSDC file. DAAS shall generate a DIC AE9 with Status Code B8 for each DIC AU7 matched to the supply source indicated by the RIC in rp 4-6 of the DIC AU7.~~

~~C8.6.4. When a request for disposition instructions is received from the DTS, DAAS shall match the TCN with the TCN in all applicable DIC AU7 transactions in the TSDC file. DAAS shall provide to the designated canceling Component contact point the TCMD transaction data, plus all supporting DIC AU7 transactions that comprise the shipment.~~

~~C8.6.5. For DIC AU7 transactions on which confirmation/denial shipment diversion, or request for disposition instruction transactions are not received within 21 days of the date of the mass or universal cancellation request, DAAS shall initiate a shipment tracer action under DTR 4500.9-R procedures to the port of embarkation (POE) indicated in rp 78-80 of the DIC AU7.~~

~~C8.6.6. When confirmation/denial of diversion or request for disposition instruction transactions are received from the transportation clearance authorities, and DAAS does not find a corresponding DIC AU7 record within the TSDC file, DAAS shall forward the transactions to the shipping activity identified in the transportation mass/universal cancellation status transactions.~~

Enclosure 4

Revisions to DLMS Implementation Conventions

#	Location	869C (4010) Requisition Cancellation	Reason
1.	DLMS Introductory Notes	<u>Add ADC 1132</u> <i>- ADC 1132, Implementation of Mass/Universal Cancellation Procedures under the DLMS and Administrative Realignment of Procedures in DLM 4000.25, Volume 2 and DLM 4000.25-1</i>	Identifies DLMS Changes included in the DLMS IC
2.	DLMS Introductory Notes	<u>Delete Federal Notes, add DLMS Note #1, and Renumber Remaining Notes</u> DLMS Note: <i>1. Organizations use this transaction set to request cancellation of previously submitted requisitions, regardless of current transaction status. Authorized organizations use this transaction to request mass or universal cancellation of requisitions. Sources of supply use this transaction to follow-up on the action taken in response to a request for mass or universal cancellation.</i>	Administrative update
3.	DLMS Introductory Notes	<u>Add Renumbered DLMS Introductory Note 3.e.</u> DLMS Note: <i>3e. Data associated with a DLMS enhancement authorized for implementation by modernized systems under DLMS migration. This data (including expanded field sizes) should be adopted during, or subsequent, to modernization when applicable to the Component's business process. Prior coordination is not required. Components should ensure that inclusion of this data in a DLMS transaction does not cause inappropriate rejection of the transaction.</i>	Administrative update
4.	1/ST02/10	<u>Move Federal Note to DLMS Note</u>	Administrative update
5.	1/BSI01/20	<u>Federal Note to DLMS Note</u> Federal DLMS Note: <i>1. Use Code "Z" for this data element to satisfy mandatory X12 syntax requirements.</i>	Administrative Update
6.	1/BSI02/20	<u>Move Federal Note to DLMS Note</u>	Administrative update
7.	1/BSI06/20	<u>Move Federal Note to DLMS Note</u>	Administrative update

#	Location	869C (4010) Requisition Cancellation	Reason
8.	1/BSI09/20	<p><u>Move Federal Note to DLMS Note</u></p> <p>C Cancelled Federal DLMS Note: Use for universal cancellation when all applicable requisitions must be cancelled.</p>	Administrative update
9.	1/BSI09/20	<p><u>Update DLMS note for Code AW</u></p> <p>AW Mass Cancellation DLMS Note: Use <i>for mass cancellations for all applicable requisitions, except those previously modified citing when requisitions with Special Requirements Code 555</i> E <i>indicating that they</i> are not to be cancelled.</p>	Correct typographical error changing special requirements code “E” to “555” to align with established MILSTRIP procedures.
10.	2/HL/10	<p><u>Move Federal Notes to DLMS Notes and update note 2</u></p> <p>DLMS Note: 1. The transaction set hierarchical data structure is organization information followed by transaction specific information. 2. For universal or mass cancellations use ONLY a single 2/HL/010 address loop <i>followed by one or more transaction loops as required for each ship-to location. Be sure to use the appropriate hierarchical parent ID number to associate each transaction loop to its appropriate address loop.</i> 3. For individual cancellations use a 2/HL/010 address loop followed by one or more transaction loops.</p>	Enhance functionality to support current MILSTRIP functionality allowing a single transaction to identify multiple ship-to activities and associated supply information for cancellation action.
11.	2/HL01/10	<u>Move Federal Note to DLMS Note</u>	Administrative update
12.	2/HL02/10	<p><u>Move Federal Note to DLMS Note and update</u></p> <p>DLMS Note: Must use in every 2/HL/010 transaction loop iteration to identify the address loop with which the current loop is associated. Data element content is the sequential number assigned to the 2/HL/010 organization loop iteration and serves as the cross-reference between transaction set level organization data and associated transactions.</p>	Administrative update
13.	2/HL03/10	<u>Move Federal Notes to DLMS Notes</u>	Administrative update

#	Location	869C (4010) Requisition Cancellation	Reason
14.	2/DTM/30	<u>Move Federal Notes to DLMS Notes</u>	Administrative update
15.	2/DTM01/30	<u>Move Federal Note to DLMS Note for Qualifiers 196 and 197</u>	Administrative update
16.	2/LIN/50	<u>Move Federal Note to DLMS Note</u>	Administrative update
17.	2/QTY/80	<u>Move Federal Note to DLMS Note</u>	Administrative update
18.	2/QTY02/80	<u>Move Federal Note to DLMS Note 1 and renumber</u> Federal DLMS Note: <i>1. Express as whole number with no decimals.</i> DLMS Note: 2. A field size exceeding 5 positions (seven for FSG 13, ammunition) may not be received or understood by the recipient's automated processing system. See introductory DLMS note 3d.	Administrative update
19.	2/QTY03-01/80	<u>Delete Federal Note and Delete DLMS Note 2</u> Federal Note: Use to identify the unit of issue for material requisitioned. DLMS Note: DLMS users see the Unit of Issue and Purchase Unit Conversion Table for available codes. 2. A field size exceeding 5 positions (seven for FSG 13, ammunition) may not be received or understood by recipient's automated processing system. See introductory DLMS note 3d.	Administrative update. DLMS Note 2 is misplaced. Information content moved to 2/QTY02/80.
20.	2/GF/100	<u>Delete Federal Note</u>	Administrative update
21.	2/GF07/100	<u>Move Federal Note to DLMS Note</u>	Administrative update
22.	2/REF/105	<u>Move Federal Note to DLMS Note</u>	Administrative update
23.	2/REF01/105	<u>Delete Federal Note and Update DLMS note 1</u> Federal Note: Use any code. DLMS Note: 1. When entering <i>processing a mass/universal requisition cancellation request to a procurement activity, cite</i> a contract number (code CT). <i>Use</i> codes 83, C7, and OQ, as needed, to further identify the applicable number in 2/REF04.	Clarify the requirement to provide the contract number and other relevant data for mass/universal requisition cancellations to a procurement activity.

#	Location	869C (4010) Requisition Cancellation	Reason
24.	2/REF04-03	<p data-bbox="482 195 1140 264"><u>Delete Federal Note and Add Qualifiers 83, C7, OQ and Associated DLMS Notes</u></p> <p data-bbox="482 321 1105 390">Federal Note: For valid codes, refer to REF04-C04001.</p> <p data-bbox="482 405 1094 474">83 Extended (or Exhibit) Line Item Number (ELIN)</p> <p data-bbox="482 489 1130 663">DLMS Note: Use with REF01 code CT, the contract number, to identify the Exhibit Line Item Number (ELIN), or the ELIN including the Sub Exhibit Line Item Number (SUBELIN), as appropriate.</p> <p data-bbox="482 716 924 743">C7 Contract Line Item Number</p> <p data-bbox="482 758 1143 974">DLMS Note: Use with the REF01 code CT, the contract number, to identify the Contract Line Item Number (CLIN), the CLIN including the Sub Contract Line Item Number (SUBCLIN), or the Agreement Line Item Number (ALIN), as appropriate.</p> <p data-bbox="482 1026 753 1054">OQ Order Number</p> <p data-bbox="482 1068 1133 1178">DLMS Note: Use to identify the call number or order number, if applicable.</p>	<p data-bbox="1153 195 1468 338">Allow ELIN, CLIN, and Order Number to be carried in the first three composites, as required.</p>

#	Location	869C (4010) Requisition Cancellation	Reason
25.	2/REF04-05	<p data-bbox="482 195 1123 264"><u>Add Qualifiers 83, C7, OQ and Associated DLMS Notes</u></p> <p data-bbox="482 321 1094 390">83 Extended (or Exhibit) Line Item Number (ELIN)</p> <p data-bbox="482 405 1130 583">DLMS Note: Use with REF01 code CT, the contract number, to identify the Exhibit Line Item Number (ELIN), or the ELIN including the Sub Exhibit Line Item Number (SUBELIN), as appropriate.</p> <p data-bbox="482 632 922 663">C7 Contract Line Item Number</p> <p data-bbox="482 678 1143 890">DLMS Note: Use with the REF01 code CT, the contract number, to identify the Contract Line Item Number (CLIN), the CLIN including the Sub Contract Line Item Number (SUBCLIN), or the Agreement Line Item Number (ALIN), as appropriate.</p> <p data-bbox="482 938 751 970">OQ Order Number</p> <p data-bbox="482 984 1135 1094">DLMS Note: Use to identify the call number or order number, if applicable.</p>	Allow ELIN, CLIN, and Order Number to be carried in the first three composites, as required.
26.	2/N1/110	<u>Delete Federal Note</u>	Administrative update
27.	2/N101/110	<u>Delete Federal Note</u>	Administrative update
28.	2/N101/110	<u>Move Federal Note to DLMS Note for Qualifier AN</u>	Administrative update
29.	2/N101/110	<p data-bbox="482 1335 1114 1367"><u>Revise DLMS Note associated with Qualifier ZG</u></p> <p data-bbox="482 1423 776 1455">ZG Present Address</p> <p data-bbox="482 1470 1146 1619">DLMS Note: When requesting cancellation by <i>ship-to</i> DoDAAC, use in mass or universal cancellation requests to identify the organization.</p>	Clarification.

#	Location	869C (4010) Requisition Cancellation	Reason
30.	2/N103/110	<p>Delete Qualifiers 1 and 9</p> <p>1 D-U-N-S Number, Dun & Bradstreet DLMS Note: DLMS enhancement; see introductory DLMS note 2a.</p> <p>9 D-U-N-S+4, D-U-N-S Number with Four Character Suffix DLMS Note: DLMS enhancement; see introductory DLMS note 2a.</p>	These qualifiers were marked as DLMS enhancements for possible future use. No procedures have been established regarding their use and there are no plans.
31.	2/N103/110	<p>Revise DLMS Notes as shown:</p> <p>92 Assigned by Buyer or Buyer's Agent DLMS Note: <i>1. Use with N101 Code XN to identify the Shop Service Center or Shop Store. Refer to ADC 381.</i> <i>2. Applicable to single line cancellation only.</i> DLMS enhancement; see introductory DLMS note 3a.</p>	Clarification.
32.	2/N106/110	<u>Move Federal Note to DLMS Note for Qualifier FR and TO</u>	Administrative update
33.	2/LM/170	<u>Move Federal Note to DLMS Note</u>	Administrative update
34.	2/LQ/180	<u>Move Federal Note to DLMS Note</u>	Administrative update
35.	2/LQ01/180	<u>Delete Federal Note</u>	Administrative update
36.	2/LQ01/180	<u>Move Federal Note to DLMS Note for Qualifier AL and Renumber Remaining DLMS Note</u>	Administrative update
37.	2/FA2/200	<u>Move Federal Note to DLMS Note</u>	Administrative update
38.	2/FA201/200	<u>Move Federal Note to DLMS Note for Qualifier L1</u>	Administrative update
39.	2/SE02/20	<u>Move Federal Note to DLMS Note</u>	Administrative update

#	Location	940R (4030) Materiel Release	Reason
1.	DLMS Introductory Notes	<u>Add ADC 1132</u> - ADC 1132, Implementation of Mass/Universal Cancellation Procedures under the DLMS and Administrative Realignment of Procedures in DLM 4000.25, Volume 2 and DLM 4000.25-1	Identifies DLMS Changes included in the DLMS IC
2.	1/W0507/0200	<u>Update DLMS Note as indicated</u> 2 Change (Update) DLMS Note: 1. Use with W0506 codes NA and NE to modify previously submitted materiel release order or a disposal release order transactions. 2. The disposal release order modifications is an authorized DLMS enhancement; see introductory DLMS note 4e ^{4f} . The materiel release order modification is equivalent to passing the requisition modifier to the shipping activity to process a revision to information perpetuated from the original requisition.	Authorize the implementation of the disposal release order modification as an approved DLMS enhancement.

#	Location	940R (4030) Materiel Release	Reason
3.	1/W0506/0200	<p data-bbox="482 193 1000 226"><u>Add New DLMS Note 2 and Renumber</u></p> <p data-bbox="482 283 954 317">ND Materiel Release Cancellation</p> <p data-bbox="482 327 656 361">DLMS Note:</p> <p data-bbox="482 373 1133 552">1. Use to request cancellation (or diversion) of either an open materiel release order or redistribution order. Also used to follow up on a cancellation request. (Equates to MILSTRIP DIC AC6 or AK6).</p> <p data-bbox="482 564 1133 709"><i>2. Use to follow up on a mass or universal cancellation request. Cite action code 82 in the W0507. Authorized DLMS enhancement; see introductory DLMS note 4f. Refer to ADC 1132.</i></p> <p data-bbox="482 722 1138 1150">3. For cancellation of a materiel release order by a retail supply system to a transportation system regarding multi-packs or assemblages (e.g., medical), cancellations will be done either at the lead document number (for multi-packs) or Assemblage Identification Number (AIN) (for assemblies). Use the AIN for assemblies to provide one reference for multiple document numbers. For single line materiel release orders, the cancellation will be at the document number level. DLMS enhancement; see introductory DLMS note 4f.</p>	<p data-bbox="1153 193 1490 445">Leverage existing single line item cancellation request follow-up to also provide one for use by SoS to follow-up on mass/universal requisition cancellation actions.</p>
4.	1/W0507/0200	<p data-bbox="482 1169 797 1203"><u>Add new DLMS Note 2</u></p> <p data-bbox="482 1260 672 1293">82 Follow Up</p> <p data-bbox="482 1304 656 1337">DLMS Note:</p> <p data-bbox="482 1350 1117 1640">1. Use with W0506=NI, Redistribution Order (RDO) to identify an RDO Follow-up by ICP to the shipping activity. This transaction is used by the AF ICP to request status on a RDO shipment request sent to an internal AF storage location or an AF base retail activity (equates to DI BF7). Authorized DLMS migration enhancement in support of ECSS. Refer to ADC 405.</p> <p data-bbox="482 1696 1109 1875"><i>2. Use with W0506=ND, Materiel Release Cancellation to identify a mass/universal requisition cancellation follow-up. Authorized DLMS enhancement; see introductory DLMS note 4f. Refer to ADC 1132.</i></p>	<p data-bbox="1153 1169 1474 1388">Add action code to differentiate single line item cancellation follow-ups from mass/universal requisition cancellation follow-ups.</p>

#	Location	856S (4030) Shipment Status	Reason
1.	DLMS Introductory Notes	<u>Add ADC 1132</u> - ADC 1132, Implementation of Mass/Universal Cancellation Procedures under the DLMS and Administrative Realignment of Procedures in DLM 4000.25, Volume 2 and DLM 4000.25-1	Identifies DLMS Changes included in the DLMS IC
2.	1/BSN07/0200	<u>Add new code and associated DLMS note</u> W10 Diverted Item DLMS Note: <i>Use when shipment status indicates that action is being taken to divert the shipment in response to request for mass or universal requisition cancellation.</i>	Add action code when shipment status indicates materiel is subject to diversion.

Enclosure 5

Transaction Flow Diagrams

A. Mass/Universal Cancellation (Storage Activity) – Unsuccessful cancellation, no attempted shipment diversion

- 1) Storage Activity ships order and sends DLMS 856S/(AS_ to customer and DLMS 945A/AR_ to Source of Supply.
- 2) Requesting Activity submits DLMS 869C.
- 3) If DLMS 945A indicates that the mode of transportation was parcel post (USPS), the Ship To was a CONUS destination, or the Ship To was an OCONUS destination with a Carrier Release date that was more than 45 days prior to the receipt of the DLMS 869C, the Source of Supply will notify the Requesting Activity of unsuccessful cancellation/shipment diversion (Status Code B8). No shipment diversion action will be attempted.

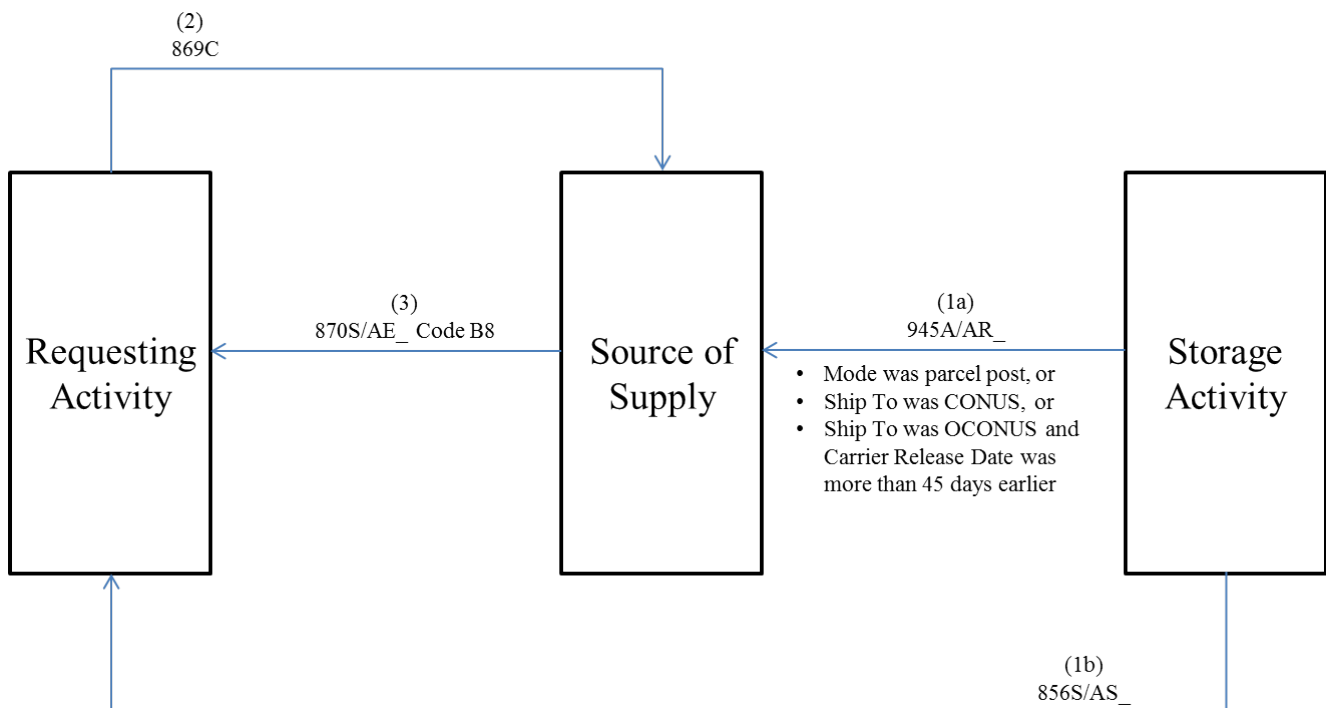

B. Mass/Universal Cancellation (Procurement Activity) – Unsuccessful cancellation, no attempted shipment diversion

- 1) Procurement Activity ships order and sends via internal or offline communications (e.g., email, phone) a Materiel Release Confirmation (DLMS 945A/AR_) or equivalent documentation to Source of Supply. Source of Supply, on behalf of the Procurement Activity, sends the DLMS 856S/AS_ to the customer.
- 2) Requesting Activity submits DLMS 869C.
- 3) If the Materiel Release Confirmation indicates that the mode of transportation was parcel post (USPS), the Ship To was a CONUS destination, or the Ship To was an OCONUS destination with a Carrier Release date that was more than 45 days prior to the receipt of the DLMS 869C, the Source of Supply will notify the Requesting Activity of unsuccessful cancellation/shipment diversion (Status Code B8). No shipment diversion action will be attempted.

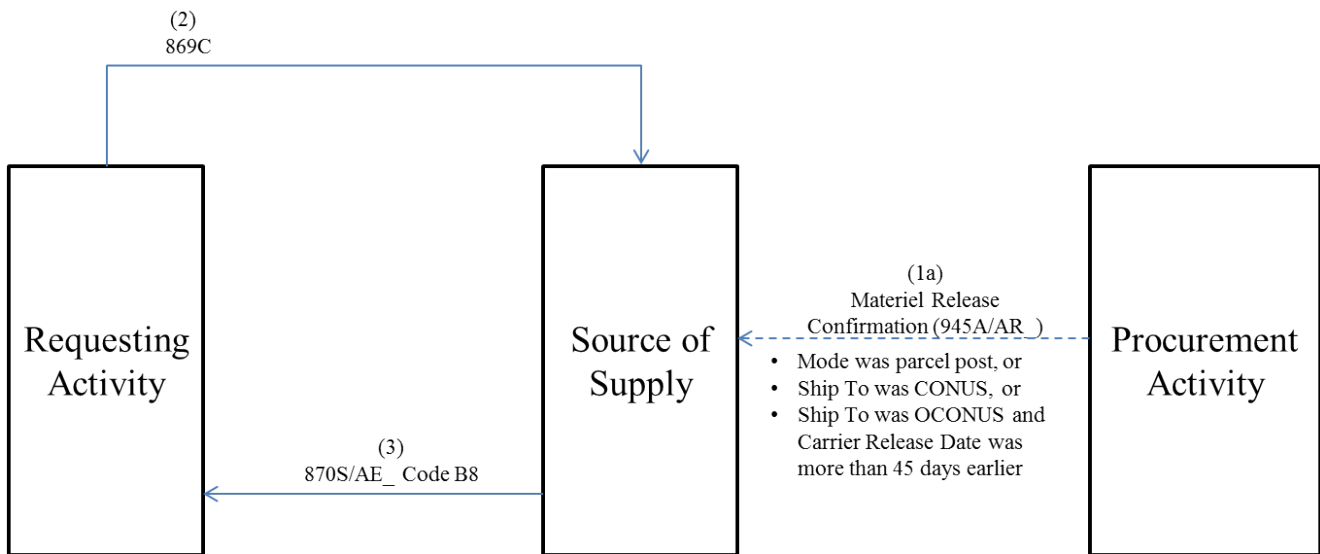

C. Mass Cancellation (Storage Activity) – Successful cancellation

- 1) Requesting Activity submits DLMS 511M/AM_ for high priority requisitions requiring continued processing (Special Requirements Code 555) and submits DLMS 869C.
- 2) Source of Supply successfully cancels open orders (Status Code BQ) and Requesting Activity can deobligate funds.
- 3) Source of Supply advises Requesting Activity of action to attempt cancellation/diversion (Status Code B9), forwards DLMS 940R/AM_ to Storage Activity citing Special Requirements Code 555 and forwards DLMS 869C/AC6.
- 4) Storage Activity continues order fulfillment actions for modified requisitions with Special Requirements Code 555 and successfully cancels all other open orders. Source of Supply notifies Requesting Activity of successful cancellation (Status Code BQ), based on Storage Activity notification of cancellation.

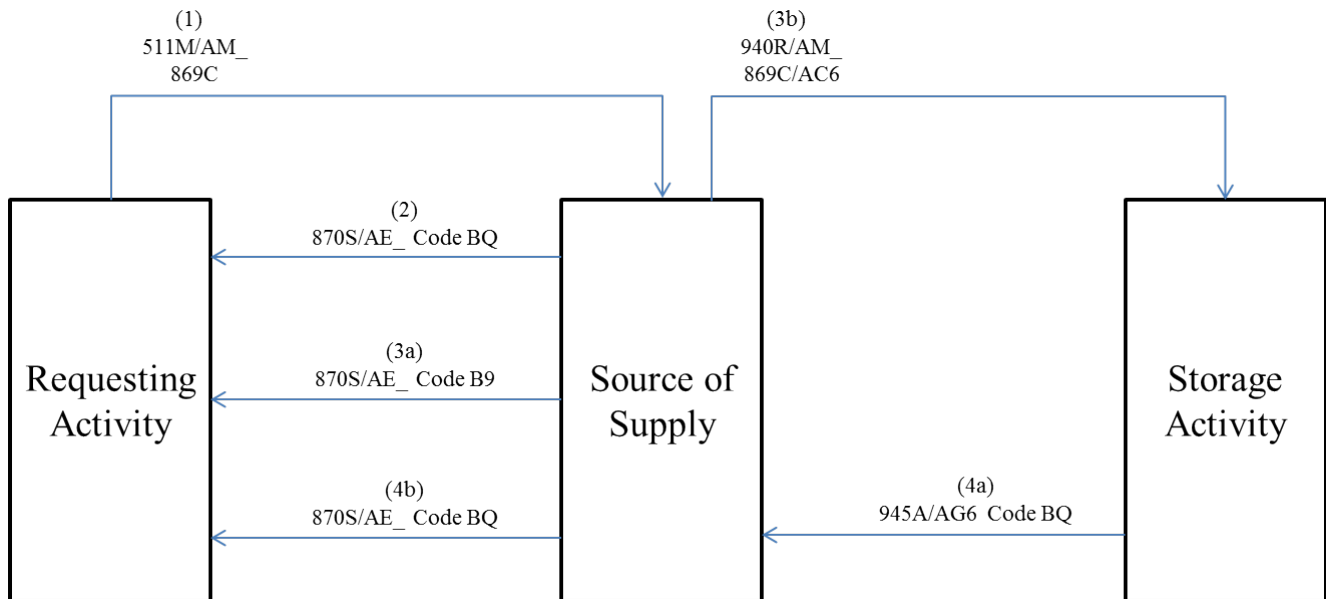

D. Mass Cancellation (Procurement Activity) – Successful cancellation

- 1) Requesting Activity submits DLMS 511M /AM_ for high priority requisitions requiring continued processing (Special Requirements Code 555) and submits DLMS 869C.
- 2) Source of Supply successfully cancels open orders (Status Code BQ or B4). Status Code BQ indicates that the Requesting Activity can deobligate funds; Status Code B4 indicates that the Requesting Activity should not deobligate funds, since there may be contract termination charges.
- 3) Source of Supply advises Requesting Activity of action to attempt cancellation/diversion (Status Code B9), forwards via internal or offline communications (e.g., email, phone) a Materiel Release Order Modification (DLMS 940R/AMP) citing Special Requirements Code 555 and Mass Requisition Cancellation (DLMS 869C/ACP) or equivalent documentation to the Procurement Activity.
- 4) Procurement Activity continues order fulfillment actions for modified requisitions with Special Requirements Code 555 and successfully cancels all other open orders. Source of Supply notifies Requesting Activity of successful cancellation (Status Code BQ or B4), based on Procurement Activity notification of cancellation.

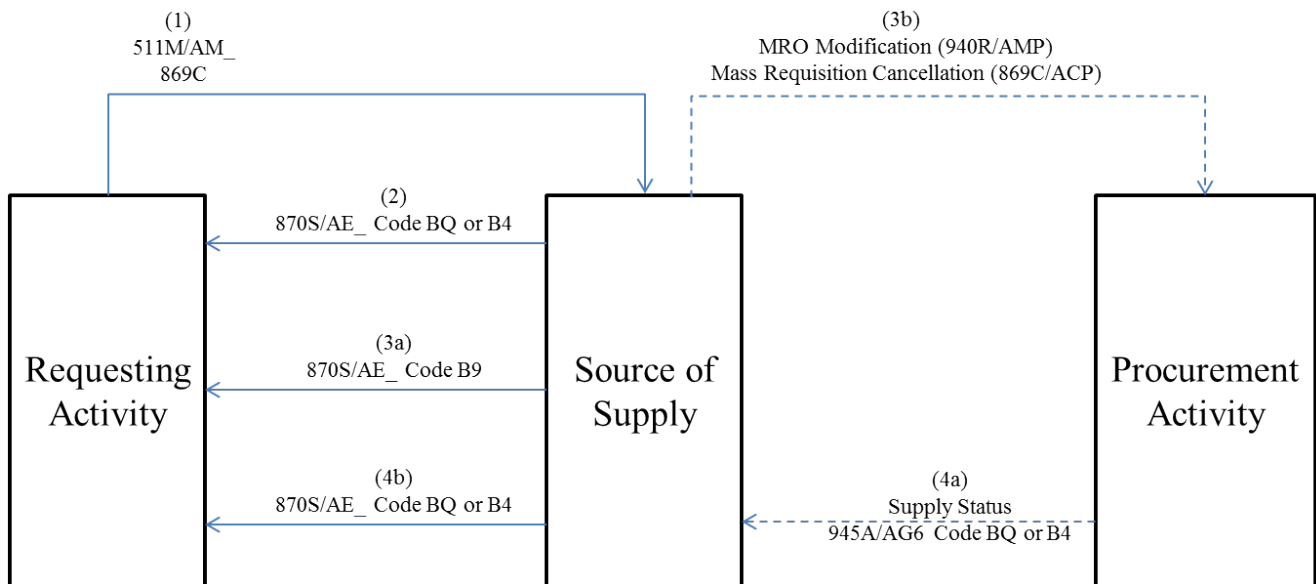

E. Universal Cancellation (Storage Activity) – Successful cancellation

- 1) Requesting Activity submits DLMS 869C.
- 2) Source of Supply successfully cancels open orders (Status Code BQ) and Requesting Activity can deobligate funds.
- 3) Source of Supply advises Requesting Activity of action to attempt cancellation/diversion (Status Code B9), forwards DLMS 869C/AC7.
- 4) Storage Activity successfully cancels open orders. Source of Supply notifies Requesting Activity of successful cancellation (Status Code BQ), based on Storage Activity notification of cancellation.

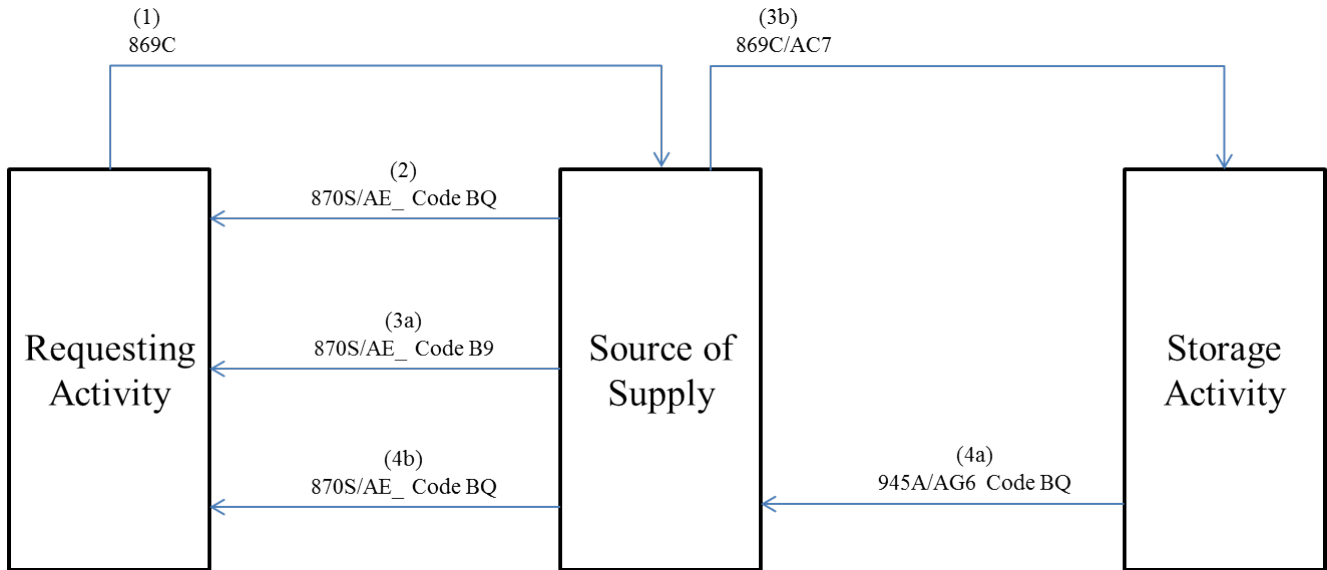

F. Universal Cancellation (Procurement Activity) – Successful cancellation

- 1) Requesting Activity submits DLMS 869C.
- 2) Source of Supply successfully cancels open orders (Status Code BQ or B4). Status Code BQ indicates that the Requesting Activity can deobligate funds; Status Code B4 indicates that the Requesting Activity should not deobligate funds, since there may be contract termination charges.
- 3) Source of Supply advises Requesting Activity of action to attempt cancellation/diversion (Status Code B9) and forwards via internal or offline communications (e.g., email, phone) a Universal Requisition Cancellation (DLMS 869C/ACM) or equivalent documentation.
- 4) Procurement Activity successfully cancels open orders. Source of Supply notifies Requesting Activity of successful cancellation (Status Code BQ or B4), based on Procurement Activity notification of cancellation.

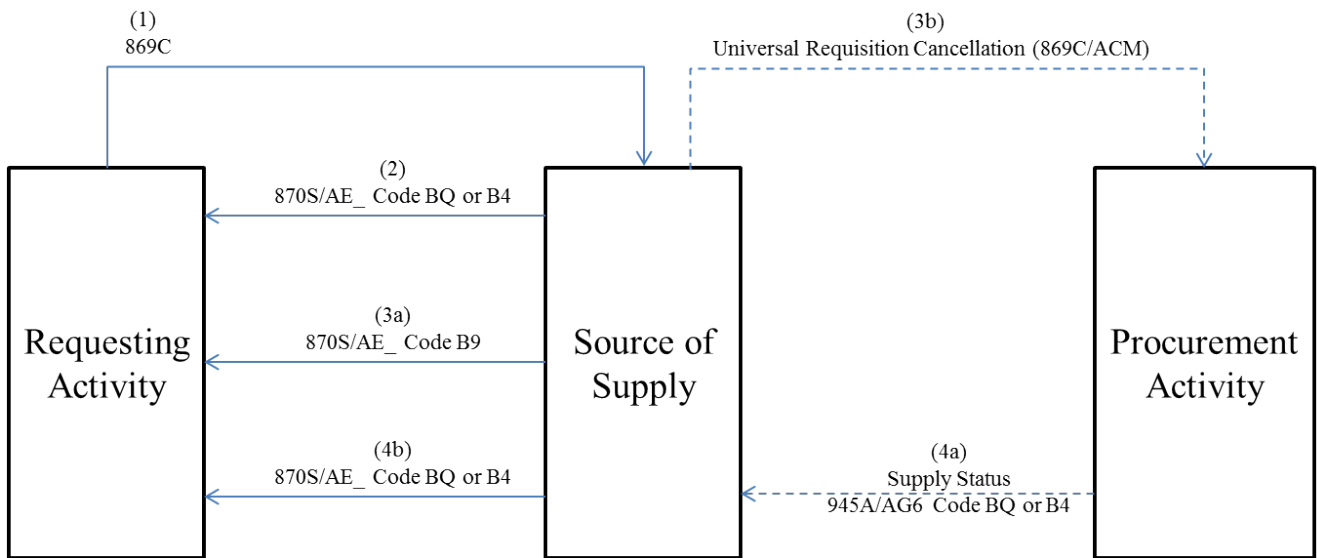

G. Mass Cancellation (Storage Activity) – Successful shipment diversion

- 1) Requesting Activity submits DLMS 511M/AM_ for high priority requisitions requiring continued processing (Special Requirements Code 555) and submits DLMS 869C.
- 2) Source of Supply advises Requesting Activity of action to attempt cancellation/diversion (Status Code B9), forwards DLMS 940R/AM_ to Storage Activity citing Special Requirements Code 555 and forwards DLMS 869C (AC6).
- 3) Storage Activity continues order fulfillment actions for modified requisitions with Special Requirements Code 555, notifies Source of Supply of attempted shipment diversion (Status Code B9) and sends DLMS 856S/AU_ to Requesting Activity for items that already shipped indicating an action taken to divert the shipment (Action Code W10).
- 4) Storage Activity notifies Source of Supply when it receives confirmation of successful shipment diversion (Status Code B6) and identifies new consignee DoDAAC. Source of Supply notifies Requesting Activity of successful shipment diversion (Status Code B6) with new consignee identified.

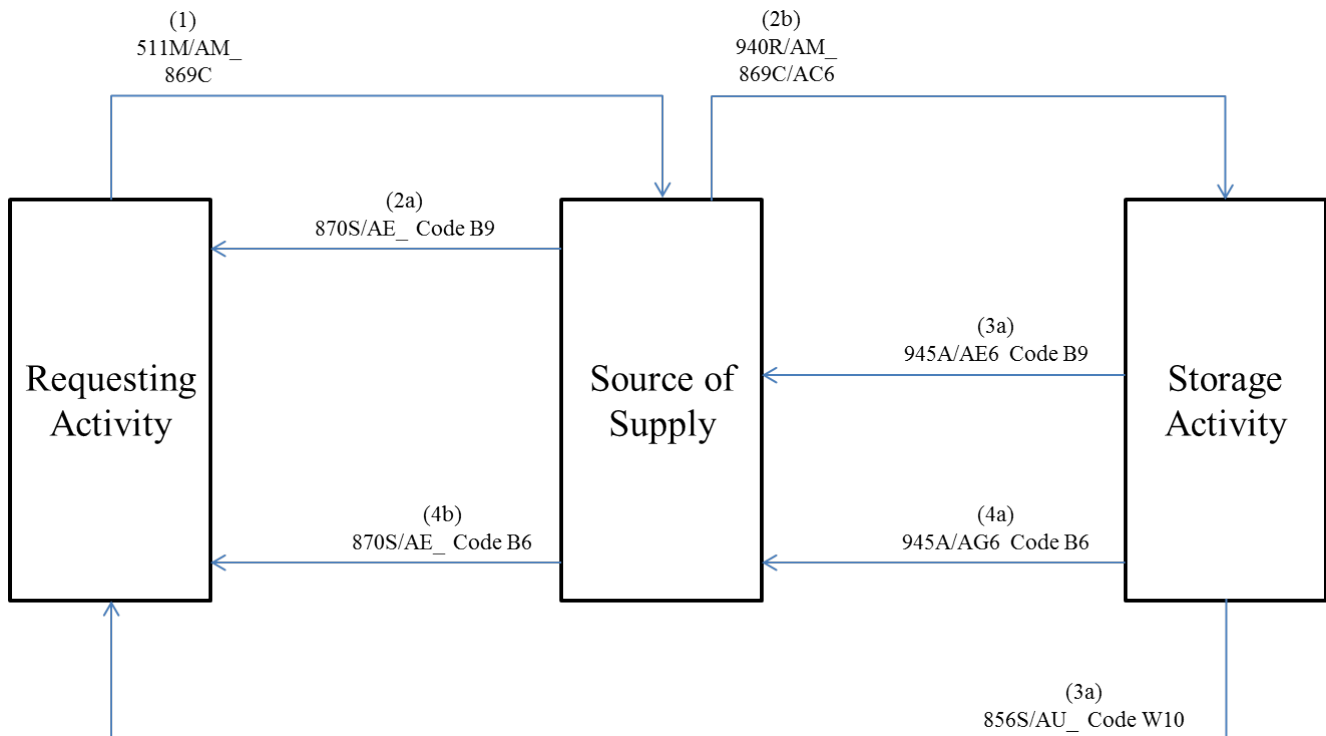

H. Mass Cancellation (Procurement Activity) – Successful shipment diversion

- 1) Requesting Activity submits DLMS 511M (AM_) for high priority requisitions requiring continued processing (Special Requirements Code 555) and submits DLMS 869C.
- 2) Source of Supply advises Requesting Activity of action to attempt cancellation/diversion (Status Code B9), forwards via internal or offline communications (e.g., email, phone) a Materiel Release Order Modification (DLMS 940R/AMP) citing Special Requirements Code 555 and Mass Requisition Cancellation (DLMS 869C/ACP) or equivalent documentation to the Procurement Activity.
- 3) Procurement Activity continues order fulfillment actions for modified requisitions with Special Requirements Code 555 and notifies Source of Supply of attempted shipment diversion (Status Code B9). Source of Supply, on behalf of the Procurement Activity, sends DLMS 856S (AU_) to Requesting Activity for items that already shipped indicating an action taken to divert the shipment (Action Code W10).
- 4) Procurement Activity notifies Source of Supply when it receives confirmation of successful shipment diversion (Status Code B6) and identifies new consignee DoDAAC. Source of Supply notifies Requesting Activity of successful shipment diversion (Status Code B6) with new consignee identified.

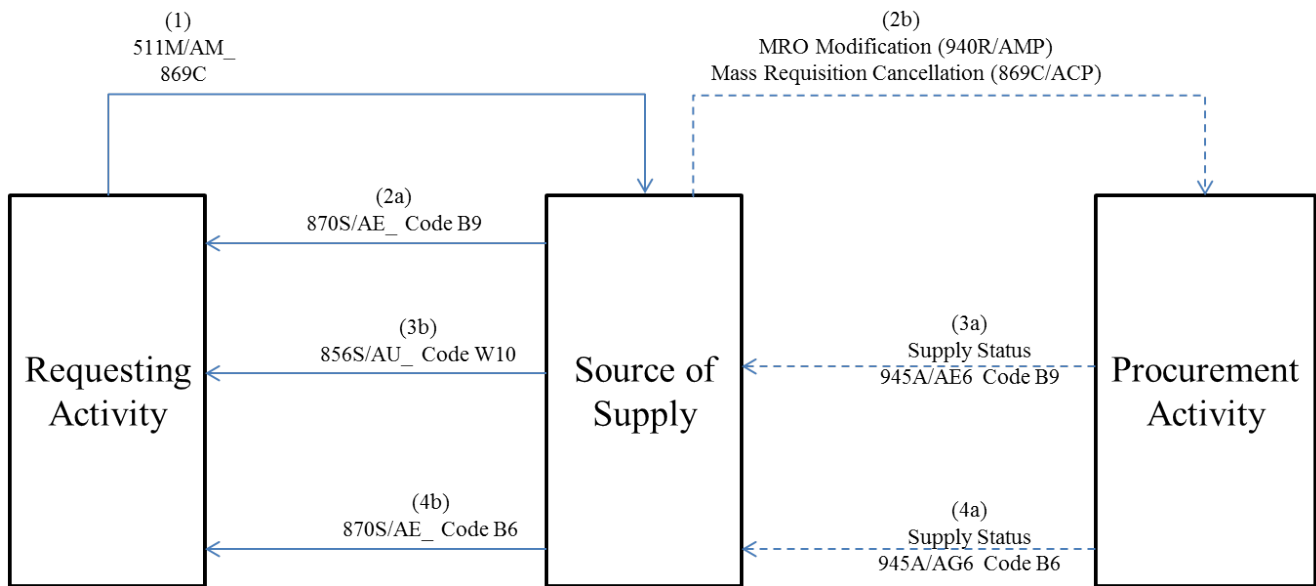

I. Universal Cancellation (Storage Activity) – Successful shipment diversion

- 1) Requesting Activity submits DLMS 869C.
- 2) Source of Supply advises Requesting Activity of action to attempt cancellation/diversion (Status Code B9) and forwards DLMS 869C/AC7.
- 3) Storage Activity notifies Source of Supply of attempted shipment diversion (Status Code B9), and sends DLMS 856S/AU_ to Requesting Activity for items that already shipped indicating an action taken to divert the shipment (Action Code W10).
- 4) Storage Activity notifies Source of Supply when it receives confirmation of successful shipment diversion (Status Code B6) and identifies new consignee DoDAAC. Source of Supply notifies Requesting Activity of successful shipment diversion (Status Code B6) with new consignee identified.

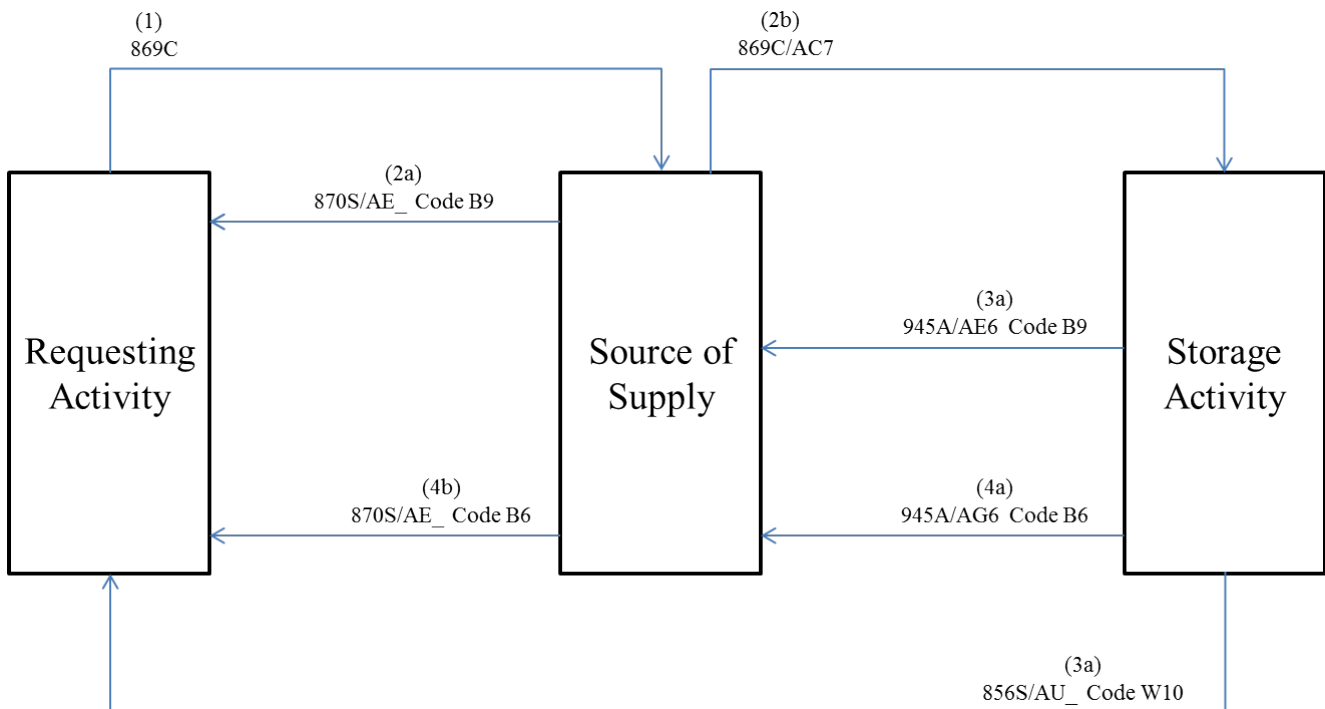

J. Universal Cancellation (Procurement Activity) – Successful shipment diversion

- 1) Requesting Activity submits DLMS 869C.
- 2) Source of Supply advises Requesting Activity of action to attempt cancellation/diversion (Status Code B9) and forwards via internal or offline communications (e.g., email, phone) a Universal Requisition Cancellation (DLMS 869C/ACM) or equivalent documentation.
- 3) Procurement Activity notifies Source of Supply of attempted shipment diversion (Status Code B9). Source of Supply, on behalf of the Procurement Activity, sends DLMS 856S/AU_ to Requesting Activity for items that already shipped indicating an action taken to divert the shipment (Action Code W10).
- 4) Procurement Activity notifies Source of Supply when it receives confirmation of successful shipment diversion (Status Code B6) and identifies new consignee DoDAAC. Source of Supply notifies Requesting Activity of successful shipment diversion (Status Code B6) with new consignee identified.

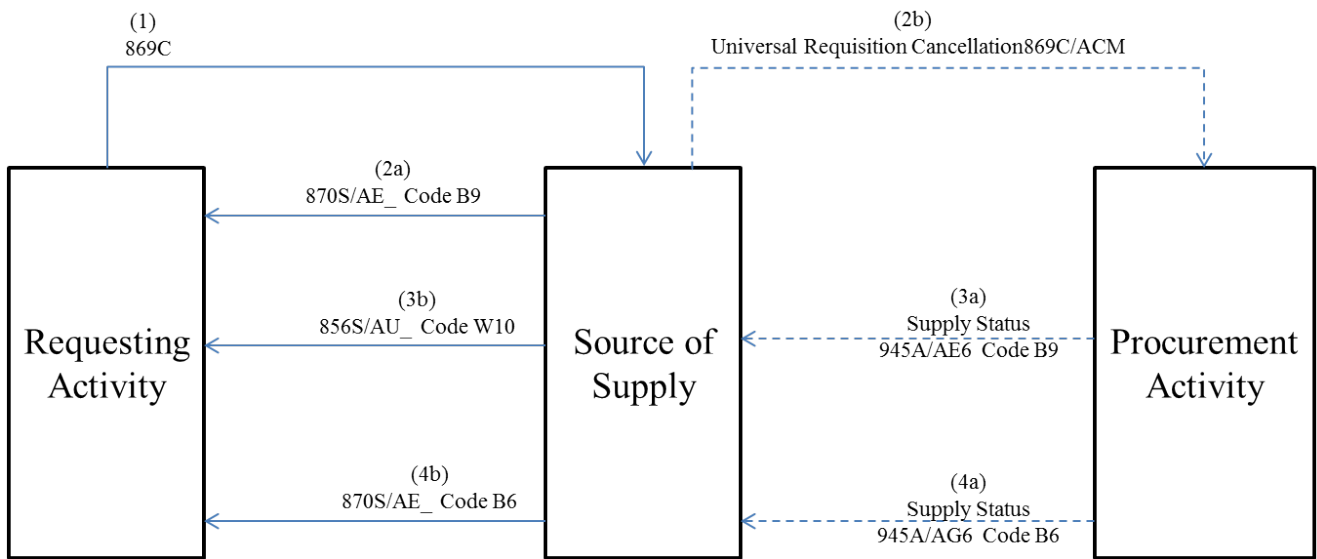

K. Mass Cancellation (Storage Activity) – Unsuccessful shipment diversion

- 1) Requesting Activity submits DLMS 511M/AM_ for high priority requisitions requiring continued processing (Special Requirements Code 555) and submits DLMS 869C.
- 2) Source of Supply advises Requesting Activity of action to attempt cancellation/diversion (Status Code B9), forwards DLMS 940R/AM_ to Storage Activity citing Special Requirements Code 555 and forwards DLMS 869C/AC6.
- 3) Storage Activity continues order fulfillment actions for modified requisitions with Special Requirements Code 555, notifies Source of Supply of attempted shipment diversion (Status Code B9) and sends DLMS 856S/AU_ to Requesting Activity for items that already shipped indicating an action taken to divert the shipment (Action Code W10).
- 4) Storage Activity sends DLMS 945A/AU0/A/B to Source of Supply when it receives confirmation of unsuccessful shipment diversion. Source of Supply notifies Requesting Activity of unsuccessful shipment diversion (Status Code B8).

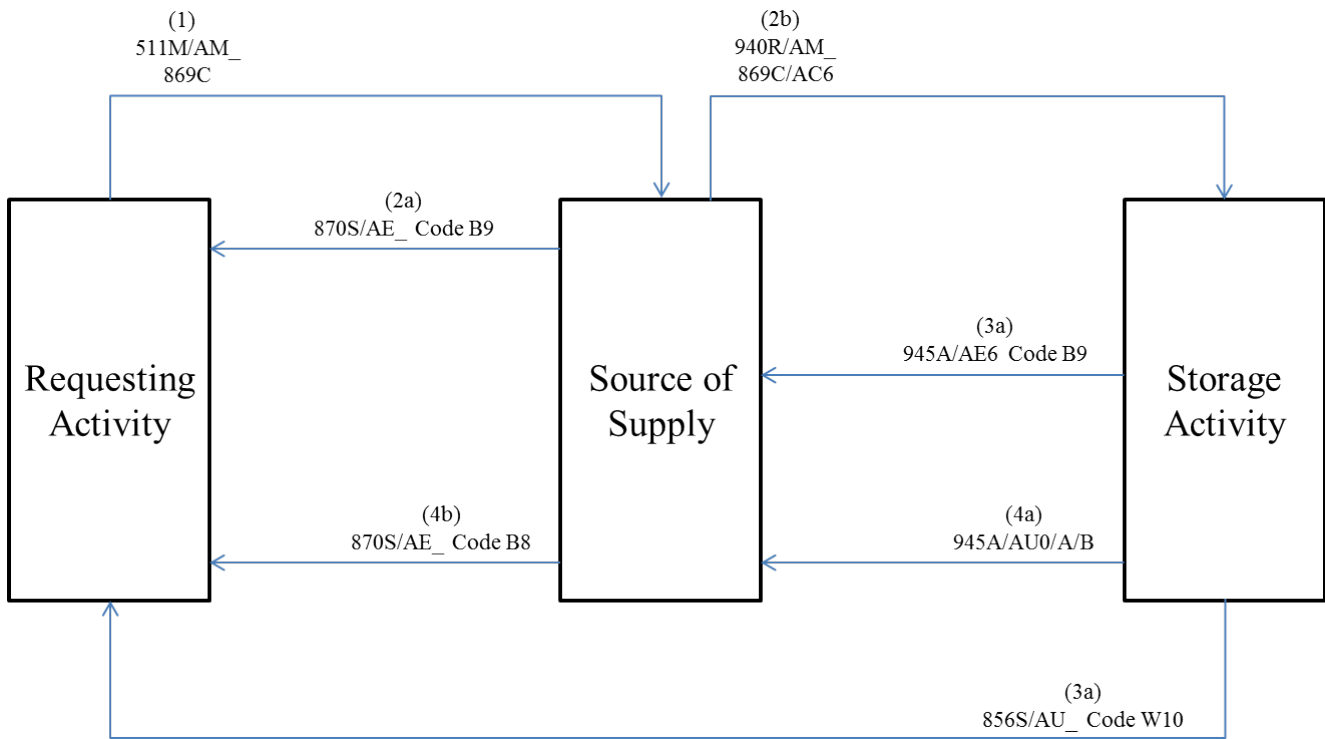

L. Mass Cancellation (Procurement Activity) – Unsuccessful shipment diversion

- 1) Requesting Activity submits DLMS 511M/AM_ for high priority requisitions requiring continued processing (Special Requirements Code 555) and submits DLMS 869C.
- 2) Source of Supply advises Requesting Activity of action to attempt cancellation/diversion (Status Code B9), forwards via internal or offline communications (e.g., email, phone) a Materiel Release Order Modification DLMS 940R/AMP citing Special Requirements Code 555 and Mass Requisition Cancellation (DLMS 869C/ACP) or equivalent documentation to the Procurement Activity.
- 3) Procurement Activity continues order fulfillment actions for modified requisitions with Special Requirements Code 555 and notifies Source of Supply of attempted shipment diversion (Status Code B9). Source of Supply, on behalf of the Procurement Activity, sends DLMS 856S/AU_ to Requesting Activity for items that already shipped indicating an action taken to divert the shipment (Action Code W10).
- 4) Procurement Activity sends DLMS 945A/AU0/A/B to Source of Supply when it receives confirmation of unsuccessful shipment diversion. Source of Supply notifies Requesting Activity of unsuccessful shipment diversion (Status Code B8).

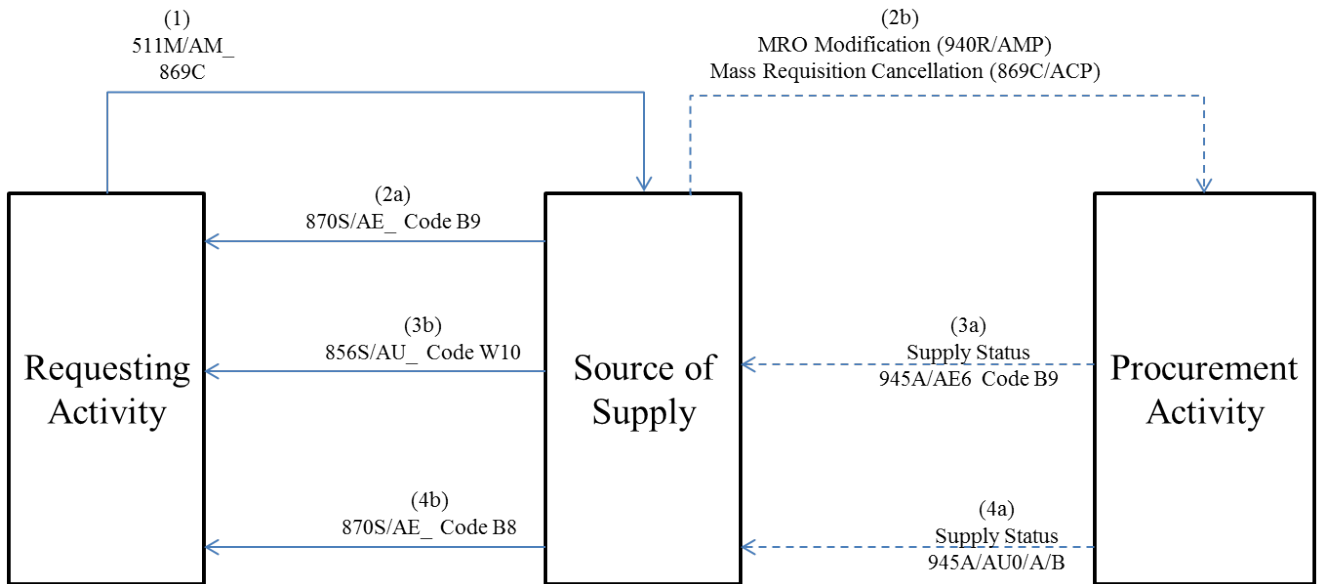

M. Universal Cancellation (Storage Activity) – Unsuccessful shipment diversion

- 1) Requesting Activity submits DLMS 869C.
- 2) Source of Supply advises Requesting Activity of action to attempt cancellation/diversion (Status Code B9) and forwards DLMS 869C/AC7.
- 3) Storage Activity notifies Source of Supply of attempted shipment diversion (Status Code B9), and sends DLMS 856S/AU_ to Requesting Activity for items that already shipped indicating an action taken to divert the shipment (Action Code W10).
- 4) Storage Activity sends DLMS 945A/AU0/A/B to Source of Supply when it receives confirmation of unsuccessful shipment diversion. Source of Supply notifies Requesting Activity of unsuccessful shipment diversion (Status Code B8).

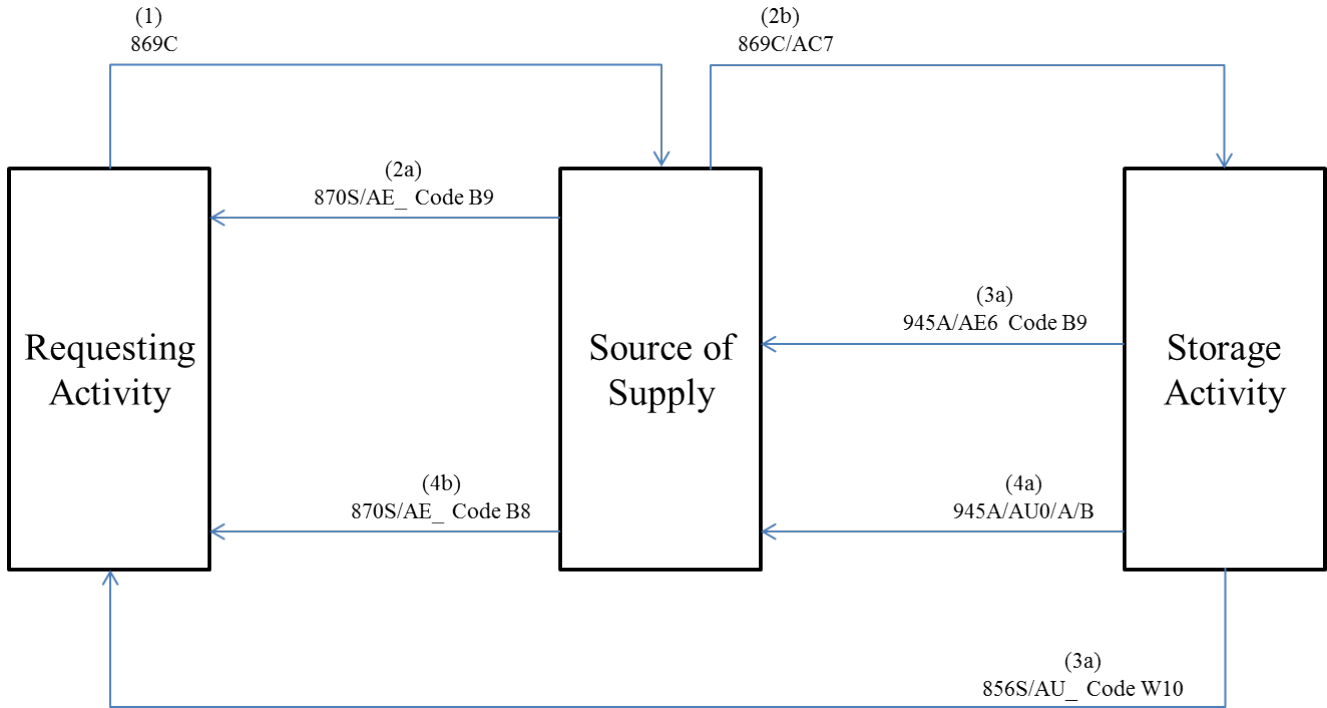

- N. Universal Cancellation (Procurement Activity) – Unsuccessful shipment diversion
- 1) Requesting Activity submits DLMS 869C.
 - 2) Source of Supply advises Requesting Activity of action to attempt cancellation/diversion (Status Code B9) and forwards via internal or offline communications (e.g., email, phone) a Universal Requisition Cancellation (DLMS 869C/ACM) or equivalent documentation.
 - 3) Procurement Activity notifies Source of Supply of attempted shipment diversion (Status Code B9). Source of Supply, on behalf of the Procurement Activity, sends DLMS 856S/AU_ to Requesting Activity for items that already shipped indicating an action taken to divert the shipment (Action Code W10).
 - 4) Procurement Activity sends via internal or offline communications (e.g., email, phone) Materiel Release Confirmation DLMS 945A/AU0/A/B or equivalent documentation to Source of Supply when it receives confirmation of unsuccessful shipment diversion. Source of Supply notifies Requesting Activity of unsuccessful shipment diversion (Status Code B8).

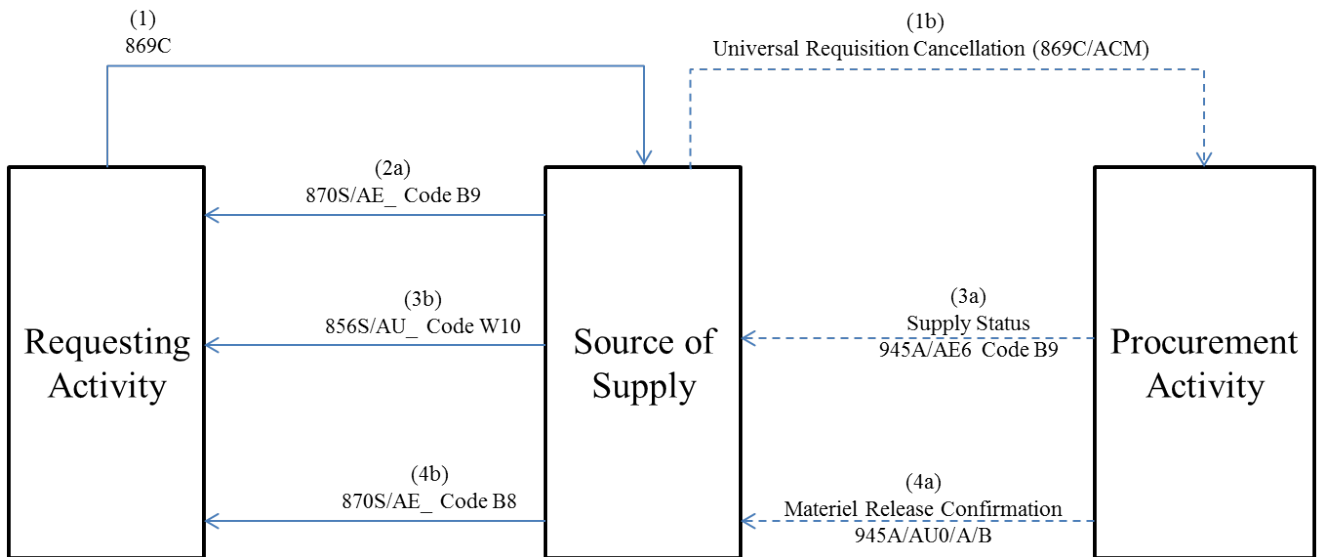

Enclosure 6
Comment Resolution for PDC 1132

	Components/Services	Responses/Comments
1.	<p>US Air Force (2/11)</p> <p>Mass cancellations occur very infrequently at the retail level. Any efforts to implement software changes in ILS-S to accommodate this PDC would fall to a very low priority due to how rare it would be that we would use this capability.</p>	<p>Concur with comment.</p> <p>DLMSO: Noted.</p>
2.	<p>US Army (6/1/2015)</p> <p>A projected implementation date cannot be determined at this time.</p>	<p>Concur with comment.</p> <p>DLMSO Response: Noted. Delayed implementation has been authorized. Army should submit system change request to implement this change and provide DLMSO implementation target date, when available.</p>
3.	<p>DLA (3/3/2015)</p>	<p>Concur.</p>
4.	<p>US Marine Corps (3/3/2015)</p>	<p>Concur.</p>
5.	<p>US Navy (4/3/2015)</p> <p>We would also request that we establish a requirement in FEDMALL that says MOES will not authorize mass/universal cancellations.</p>	<p>Concur with comment.</p> <p>DLMSO Response: Requirement removed from paragraph 9.e. Paragraph added at 4.c (1) (b) to state that mass/universal cancellations will not be initiated via FEDMALL/MOES.</p>
6.	<p>DSCA (6/1/2015)</p>	<p>Concur.</p>
7.	<p>USTRANSCOM (2/3/2015)</p>	<p>Concur.</p>