



FEDMALL

CLICK HERE TO ORDER THIS ITEM IN FEDMALL

LOG ON TO FEDMALL IN A 2nd TAB FIRST

Frame Type Expandable Tent 16x16 and 16x32

8340-00-782-3232 16' x 16' Camouflage Green Shade #483, Frame Type Expandable Tent

8340-01-503-3536 16' x 32' Camouflage Green Shade #483, Frame Type Expandable Tent

8340-01-505-8656 16' x 16' Desert Tan Shade #459, Frame Type Expandable Tent

8340-01-505-3078 16' x 32' Desert Tan Shade #459, Frame Type Expandable Tent

***** THE MOST COST EFFECTIVE SHELTER WITH MIL SPEC DURABILITY *****

The Frame Type Expandable Tent is a frame-supported tent consisting of an aluminum frame and a fabric covering of 16 oz. polyester duck. The improved seaming construction is sealed to provide leak resistant interior. There is a heater stove pipe shield in the roof. The design now includes a full vinyl liner and fabric floor. Interior fabric color is white to provide better lighting distribution. Both the fabric and frame can be extended to any length in 16 foot sections. Field name is referred to as the "Aero-Fab."



KEY

FEATURES:

- Aluminum frame
- Improved polyester duck design. - User friendly design
- Windows w/screening on all sides
- Now leak resistant design
- Stove pipe openings and ECU Ducts - Quick mobility
- Camouflage Green coated polyester blackout fabric
- 256 square feet of floor space
- Modular design can be expanded in 16 ft increments to any length desired
- Rugged: maintains structural integrity in adverse weather conditions

16' Description:

The 16' Frame Type Expandable Tent has a polyester duck fabric covering and is frame-supported. The frame is of sectionalized aluminum construction composed of collapsible arches connected by 8 ft-long purlins and braced by header bars. The fabric end walls contain a window with screen, gable vents and U-Shaped Door. The end walls are laced to the 16 foot long mid section fabric that contains four windows and two environmental control unit duct sleeves. Both the fabric and frame can be extended to any length in 16 foot sections. The tent has a floor space of 256 square feet (16'L x 16'W), 8'6" Ridge Height, and 6' Eave Height. It weighs 400 pounds and has shipping of 60 cu. ft.

32' Description:

The 32' Frame Type Expandable Tent has a polyester duck fabric covering and is frame-supported. The frame is of sectionalized aluminum construction composed of collapsible arches connected by 8 ft-long purlins and braced by header bars. The fabric end walls contain a window with screen, gable vents and U-Shaped Door. The end walls are laced to the two 16 foot long mid section fabrics that contains eight windows and four environmental control unit duct sleeves. Both the fabric and frame can be extended to any length in 16 foot sections. The tent has a floor space of 512 square feet (16'L x 32'W), 8'6" Ridge Height, and 6' Eave Height. It weighs 573 pounds and has shipping of 60 cu. Ft.

The Technical Manual for this tent is TM 10-8340-220-23P

PRODUCT SPECIFICATIONS:

- **Dimensions: 16'Length X 16'Width X 8'6"Ridge Height and 6'Eave Height**
- **Floor Area: 256 square feet**
- **Weight: 400 pounds**
- **Color: Camouflage Green**
- **Set-up Time/# of Persons: 45/4**
- **Strike Time/# of Persons: 20/4**
- **Shipping Cube: 60**

Note: Ridge Line Find 20
(2 each) is part of expandable
mid fabric section find 2.

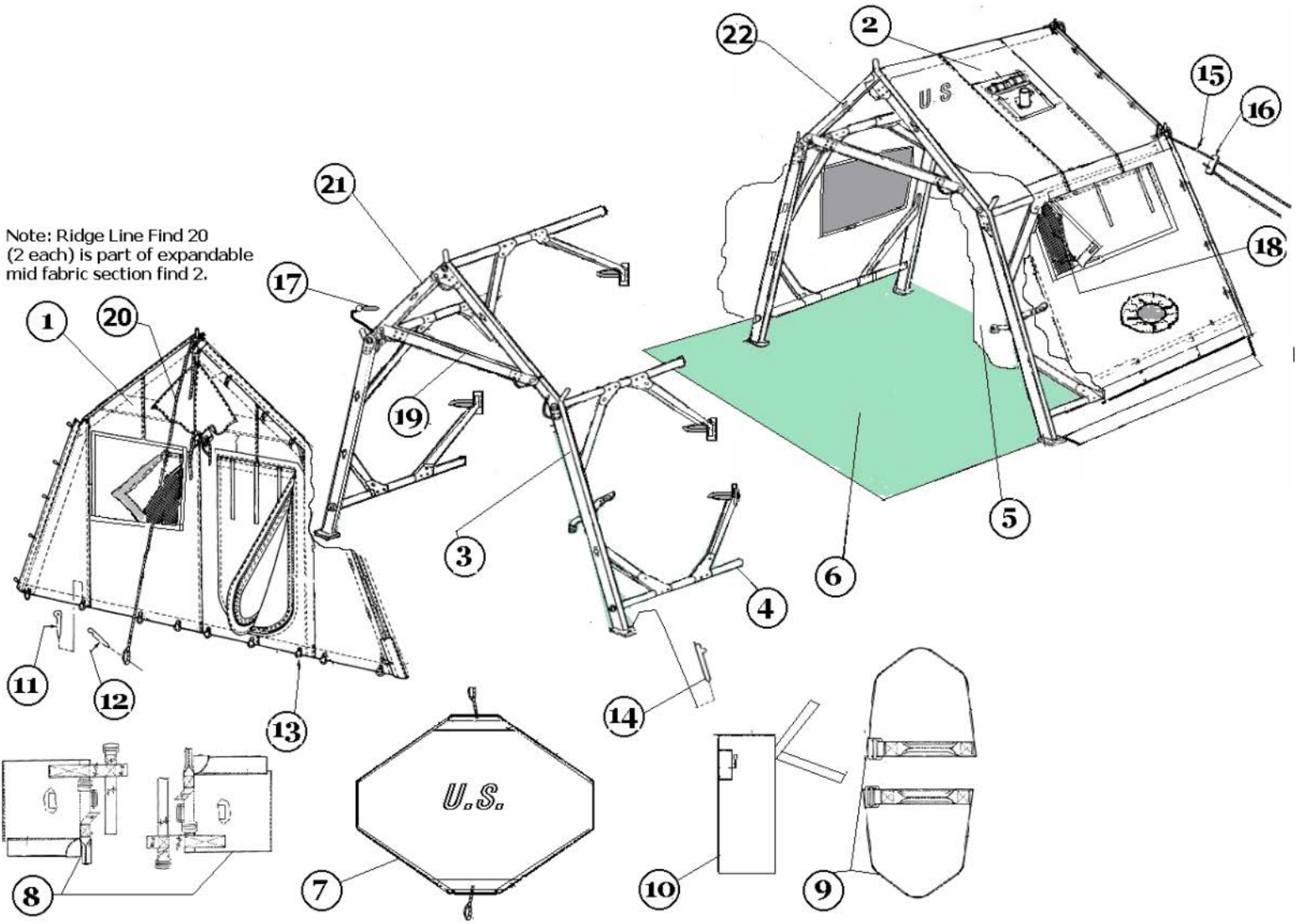

THE COMPLETE TENT SYSTEM 16' x 16' FRAME TYPE EXPANDABLE TENT (CAMOUFLAG GREEN SHADE #483), WITH THE FOLLOWING PARTS AND QUANTITIES:

NSN	DESCRIPTION, SPECIFICATION	QUANTITY	Diagram #
8340-00-566-7398	END SECTION FABRIC, (IAW) MIL-DTL-43492	2 EA	#1
8340-00-566-7416	INTERMEDIATE SECTION FABRIC, (IAW) MIL-DTL-43492	1 EA	#2
8340-00-841-4648	COVER GENERAL PURPOSE SMALL, (BLACK)	1 EA	#7
8340-01-452-7049	LINER W/TRANSPORT COVER, (IAW) MIL-DTL-43492	1 EA	#5
8340-00-234-4708	END SECTION FRAME, (IAW) MIL-DTL-43695	1 EA	#22
8340-00-556-9674	TRANSPORT COVER, ARCHES, (IAW) MIL-DTL-43492	1 EA	#9
8340-00-234-4712	EXTENDABLE SECTION FRAME, (IAW) MIL-DTL-43695	1 EA	#21
8340-00-556-9671	TRANSPORT COVER, PURLINS, (IAW) MIL-DTL-43492	1 EA	#8
8340-00-261-9749	9 INCH ALUMINUM PINS, (IAW) MIL-P-501	18 EA	#11
8340-00-261-9750	16 INCH WOOD PIN, (IAW) MIL-P-2383	10 EA	#12
8340-00-823-7451	12 INCH STEEL PINS, RED, (IAW) MIL-P-501	6 EA	#14
8340-01-186-3030	PIN TENT PIN CONTAINER, (IAW) MIL-DTL-44243, 5-4-7847	1 EA	#10
8340-00-453-5646	FLOOR, 16' FABRIC, (IAW) MIL-DTL-43492 interoperable design	1 EA	#6



THE COMPLETE TENT SYSTEM 16' x 16' FRAME TYPE EXPANDABLE TENT (DESERT TAN SHADE #686), WITH THE FOLLOWING PARTS AND QUANTITIES:





NSN	DESCRIPTION	QUANTITY	Diagram #
8340-01-504-6278	END SECTION FABRIC ASSY, TAN, (IAW) MIL-DTL-43492	2 EA	#1
8340-01-504-6274	16' INTERMEDIATE SECTION FABRIC ASSY., TAN, (IAW) MIL-DTL-43492	1 EA	#2
8340-00-841-4648	COVER GENERAL PURPOSE SMALL, (BLACK)	1 EA	#7
8340-01-452-7049	LINER W/TRANSPORT COVER, (IAW) MIL-DTL-43492	1 EA	#5
8340-00-234-4708	END SECTION FRAME, (IAW) MIL-DTL-43695	1 EA	#22
8340-00-556-9674	TRANSPORT COVER, ARCHES, (IAW) MIL-DTL-43492	1 EA	#9
8340-00-234-4712	EXTENDIBLE SECTION FRAME, (IAW) MIL-DTL-43695	1 EA	#21
8340-00-556-9671	TRANSPORT COVER, PURLINS, (IAW) MIL-DTL-43492	1 EA	#8
8340-00-261-9749	9 INCH ALUMINUM PINS, (IAW) MIL-P-501	18 EA	#11
8340-00-261-9751	24 INCH WOOD PIN, (IAW) MIL-P-2383	10 EA	#12
8340-00-823-7451	12 INCH STEEL PINS, RED, (IAW) MIL-P-501	6 EA	#14
8340-01-186-3030	PIN TENT PIN CONTAINER, (IAW) MIL-DTL-44243, 5-4-7847	1 EA	#10
8340-00-453-5646	FLOOR, 16' FABRIC, (IAW) MIL-DTL-43492 interoperable design	1 EA	#6

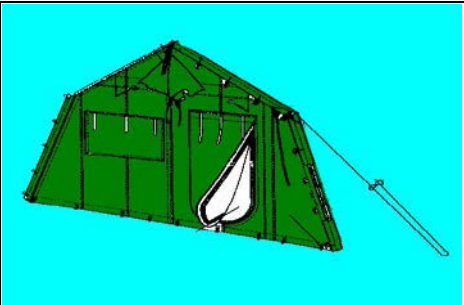
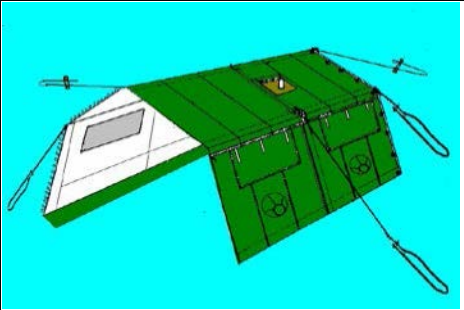
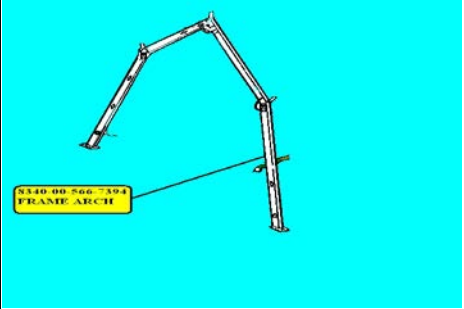

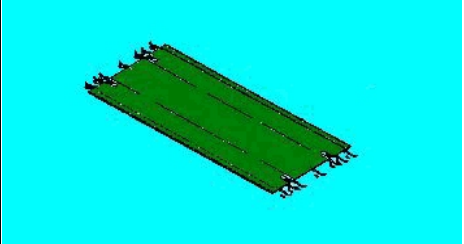

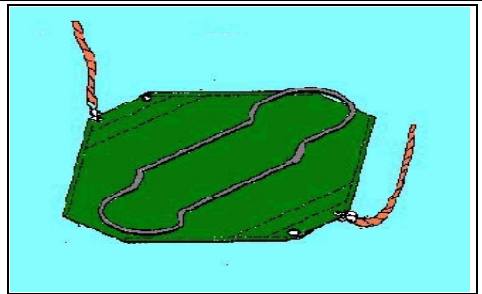

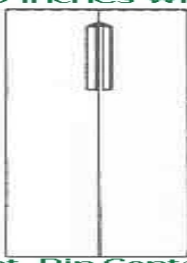
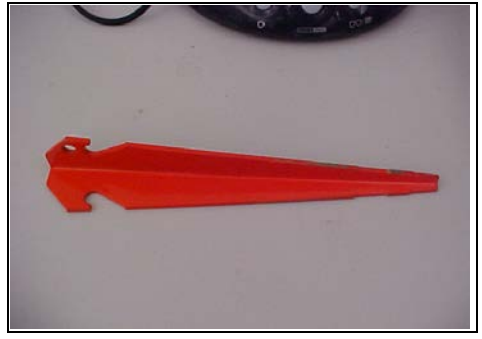
Frame Type Expandable Tent 16x16 System 1 includes the following:

	NSN	DESCRIPTION	QUANTITY
1.	Green 8340-00-566-7398 Tan 8340-01-504-6278	End Section Fabric Includes: 1 Guy Line, Eave Line 8' 8340-00-252-2269 9 Footstops, 9" 8340-00-252-2299 Slip, Tent Line 8340-00-252-2269	2
2.	Green 8340-00-566-7416 Tan 8340-01-504-6274	Intermediate Section Fabric Includes: 18 Footstops, 9" 8340-00-252-2299 6 Guy Lines, Eave Line 8' 8340-00-252-2269 2 Guy Lines, Ridge Line 13' 8340-00-252-2271 8 Tent, Line Slips 8340-00-205-2269 16 Inch Wood Pin 8340-00-261-9750 Window Pane 8340-00-566-7387	1
3.	8340-00-566-7394	Arch, Tent Frame (Does not include header)	3
4.	8340-00-238-9806	Purlin, Assembly	10
5.	8340-01-452-7049	Liner Assembly (one pair – 8' long sections per tent)	1
6.	8340-01-186-5646	Floor, 16' Fabric w/fastener tape. Mates to liner and extendable so two or more floors can be attached for longer tents.	1
7.	8340-00-841-4648	Cover, General Purpose, Small	1
8.	8340-00-556-9671	Transport Cover, Purlins (one cover = one pair with straps) Fits 10 purlins per tent	1
9.	8340-00-556-9674	Transport Cover, Arches (one cover = one pair with straps) Fits three arches and three header bars	1
10.	8340-01-186-3030	Bag, Pin Container	1
11.	8340-00-261-9749	9 Inch Aluminum Pin	18
12.	8340-00-261-9750	16 Inch Wood Pin	10
13.	8340-00-823-7451	12 Inch Steel Pin, Red	6
14.	8340-00-556-9697	Header (Bar) Assembly 8340-01-477-9657 (Alternate) CABLE HEADER, ASSEMBLY	3

Spare Parts & Options for the 16x16 Green:

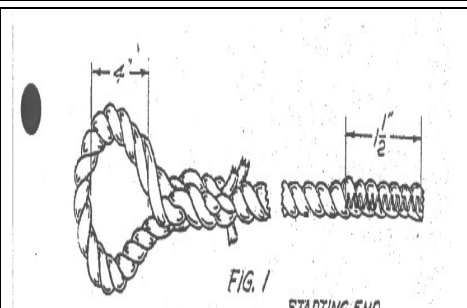
	NSN	DESCRIPTION	Photo
1.	8340-00-566-7398	End Section Fabric Includes: 1 Guy Line, Eave Line 8' 8340-00-252-2269 9 Footstops, 9" 8340-00-252-2299 Slip, Tent Line 8340-00-252-2269	
2.	8340-00-566-7416	Intermediate Section Fabric Includes: 18 Footstops, 9" 8340-00-252-2299 6 Guy Lines, Eave Line 8' 8340-00-252-2269 2 Guy Lines, Ridge Line 13' 8340-00-252-2271 8 Tent, Line Slips 8340-00-205-2269 16 Inch Wood Pin 8340-00-261-9750 Window Pane 8340-00-566-7387	
3.	8340-00-566-7394	Arch, Tent Frame (Does Not Include Header)	
4.	8340-00-238-9806	Purlin, Assembly	
5.	8340-01-452-7049	LINER ASSEMBLY (one pair – 8' long sections per tent)	
6.	8340-01-453-5646	Floor, 16' Fabric w/fastener tape. Mates to liner and extendable so two or more floors can be attached for longer tents.	

7.	8340-00-841-4648	Cover, General Purpose, Small	
8.	8340-00-556-9671	Transport Cover, Purlins (one cover = one pair with straps)	
9.	8340-00-556-9674	Transport Cover, Arches (one cover = one pair with straps)	
10.	8340-01-186-3030	Bag, Pin Container	<p>15 inches wide</p>  <p>36 inches deep</p> <p>Tent, Pin Container (bag w/ tie tapes)</p>
11.	8340-00-261-9749	9 Inch Aluminum Pin	
12.	8340-00-261-9750	16 Inch Wood Pin	

13.	8340-00-252-2299	Footstop, 9"	
14.	8340-00-823-7451	12 Inch Steel Pin, Red	
15.	8340-00-252-2269	EAVE LINE, TENT: GUY, 8'	
16.	8340-00-205-2759	Slip, Tent Line	
17.	5340-00-177-4076	Pin And Ring Quick Release	
18.	8340-00-566-7387	Window, Pane	

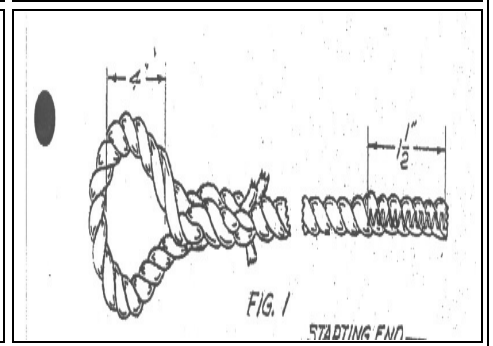
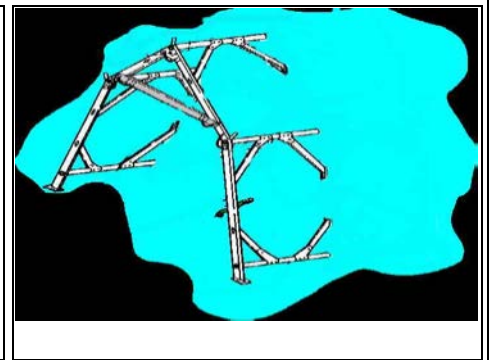
19.	8340-00-556-9697	<p>Header Assembly</p> <p>8340-01-477-9657 Alternate CABLE HEADER, ASSEMBLY most current contracts now include the cable header.</p>	
20.	8340-00-252-2271	<p>RIDGE LINE, TENT: GUY 13'</p>	
21.	8340-00-234-4708	<p>End Section, Frame Includes: Header Assembly (2) 8340-00-234-9697, Arch, Tent Frame (2) 8340-00-566-7394, Purlin, Assembly (5) 8340-00-238-9806, 12 Inch Steel Pins, Red 8340-01-823-7451 Pin and Ring Quick Release 5340-00-177-4076</p>	
22.	8340-00-234-4712	<p>Expandable Section Frame Includes: Purlin, Assembly (5) 8340-00-238-9806, Header Assembly (1) 8340-00-556-9697, Arch, Tent Frame (1) 8340-00-566-7394, 12 Inch Steel Pins, Red 8340-00-823-7451 Pin and Ring Quick Release 5340-00-177-4076</p>	