

AMENDMENT OF SOLICITATION/MODIFICATION OF CONTRACT

1. CONTRACT ID CODE J	PAGE 1	OF PAGES 13
---------------------------------	------------------	-----------------------

2. AMENDMENT/MODIFICATION NO. P00203	3. EFFECTIVE DATE See Blk. 16C	4. REQUISITION/PURCHASE REQ. NO. See Block 14	5. PROJECT NO. (If applicable)
6. ISSUED BY DLA TROOP SUPPORT SUBSISTENCE SUPPLY CHAIN 700 ROBBINS AVENUE PHILADELPHIA PA 19111-5096 USA Initiator: Priscilla Reed PSPTRC6 Tel: 215-737-2869 FAX: 215-737-4115 Email: PRISCILLA.REED@DLA.MIL	CODE SPM3S1	7. ADMINISTERED BY (If other than Item 6)	CODE S1103A
		DCMA ATLANTA 2300 LAKE PARK DRIVE SMYRNA GA 30080-0000 USA	

8. NAME AND ADDRESS OF CONTRACTOR (No., street, county, State and ZIP Code)	(X)	9A. AMENDMENT OF SOLICITATION NO.
SOPAKCO, INC. SOPAKCO PACKAGING 118 S CYPRESS ST MULLINS SC 29574-3004 USA		9B. DATED (SEE ITEM 11)
	X	10A. MODIFICATION OF CONTRACT/ORDER NO. SPM3S1-12-D-Z108
		10B. DATED (SEE ITEM 13) 2011 NOV 16
	CODE 6D623	FACILITY CODE

11. THIS ITEM ONLY APPLIES TO AMENDMENTS OF SOLICITATIONS

The above numbered solicitation is amended as set forth in Item 14. The hour and date specified for receipt of Offers is extended, is not extended.

Offers must acknowledge receipt of this amendment prior to the hour and date specified in the solicitation or as amended, by one of the following methods:

(a) By completing Items 8 and 15, and returning _____ copies of the amendment; (b) By acknowledging receipt of this amendment on each copy of the offer submitted; or (c) By separate letter or telegram which includes a reference to the solicitation and amendment numbers. FAILURE OF YOUR ACKNOWLEDGMENT TO BE RECEIVED AT THE PLACE DESIGNATED FOR THE RECEIPT OF OFFERS PRIOR TO THE HOUR AND DATE SPECIFIED MAY RESULT IN REJECTION OF YOUR OFFER. If by virtue of this amendment you desire to change an offer already submitted, such change may be made by telegram or letter, provided each telegram or letter makes reference to the solicitation and this amendment, and is received prior to the opening hour and date specified.

12. ACCOUNTING AND APPROPRIATION DATA (If required)

13. THIS ITEM APPLIES ONLY TO MODIFICATIONS OF CONTRACTS/ORDERS, IT MODIFIES THE CONTRACT/ORDER NO. AS DESCRIBED IN ITEM 14.

CHECK ONE	A. THIS CHANGE ORDER IS ISSUED PURSUANT TO: (Specify authority) THE CHANGES SET FORTH IN ITEM 14 ARE MADE IN THE CONTRACT ORDER NO. IN ITEM 10A.
X	FAR 52.243-1
	B. THE ABOVE NUMBERED CONTRACT/ORDER IS MODIFIED TO REFLECT THE ADMINISTRATIVE CHANGES (such as changes in paying office, appropriation date, etc.) SET FORTH IN ITEM 14, PURSUANT TO THE AUTHORITY OF FAR 43.103 (b).
	C. THIS SUPPLEMENTAL AGREEMENT IS ENTERED INTO PURSUANT TO AUTHORITY OF:
	D. OTHER (Specify type of modification and authority)

E. IMPORTANT: Contractor is not, is required to sign this document and return _____ copies to the issuing office.

14. DESCRIPTION OF AMENDMENT/MODIFICATION (Organized by UCF section headings, including solicitation/contract subject matter where feasible.)

See Continuation Sheet

Except as provided herein, all terms and conditions of the document referenced in Item 9A or 10A, as heretofore changed, remains unchanged and in full force and effect.

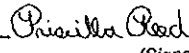
15A. NAME AND TITLE OF SIGNER (Type or print)	16A. NAME AND TITLE OF CONTRACTING OFFICER (Type or print)		
	Priscilla Reed PSPTRC6		
15B. CONTRACTOR/OFFEROR	15C. DATE SIGNED	16B. UNITED STATES OF AMERICA	16C. DATE SIGNED
(Signature of person authorized to sign)		 (Signature of Contracting Officer)	2013 DEC 18

MRE NSN: 8970-00-149-1094

All terms and conditions of the subject contract remain the same except for the following:
(continue on previous pages)

CONTINUED ON NEXT PAGE

SECTION B - SUPPLIES OR SERVICES AND PRICES OR COSTS**Sopakco Techn Data
SOPAKCO INC**

The following changes apply to the Technical Data Packaging (TDP) SPM3S1-11-R-7074 and to implement change for MRE XXXVIII (34). This modification is effective with Delivery Order 0007.

This modification is effective with Delivery order Solicitation SPM3S1-11-R-7074

Page 5 of 134, B-5,1,

Delete:

Chicken Fajita

Vegetable Lasagna

Insert:

Beef Shredded, in Barbecue Sauce

Vegetable Crumbles with Pasta in Taco Style Sauce

Page 6 of 134, B-5,2,

Delete:

Refried Beans

Potato Cheddar Soup

Insert:

Tortillas, Chipotle

Black Beans in a Seasoned Sauce

Corn Nuts, Barbeque

Pretzels, Nuggets, Honey Mustard and Onion

Technical Data Package – Solicitation SPM3S1-11-R-7074: Meal, Ready-To-Eat (MRE) and Humanitarian Daily Ration (HDR)

Tab 1, ACR-M-033

Delete ACR-M-033 in its entirety and insert ACR-M-034, 5 Sep 2013, with Change 01, 27 Sep 13, which is available at:

<https://www.troopsupport.dla.mil/subs/support/specs/frozen/frozen.asp>

The following are changes to the ACR-M-034:

CONTINUED ON NEXT PAGE

Page 3, Section C-2, A, Table I. Components - Continued;

Delete: "Tuna, Flexible Pouch, Chunk, Light, Water Packed, Lemon Pepper, Regular Salt/Sodium Level" and "A-A-20155D, Type B, Form I, Color a, Packing Media 1, Flavor 1, Salt/Sodium Level (a)".

Insert:

"Chicken Breast Fillets, Seasoned, Garlic and herb seasonings" and "A-A-20361 Type I".

"*NOTE: The current substitution of Chicken Breast Fillets, Seasoned, Type I - Garlic and Herb Seasonings is due to insufficient quantity of tuna at assemblers. Until the supply issues associated with tuna are resolved, Chicken Breast Fillet, Seasoned, Garlic and Herb Seasonings (CID and PKG&QAP A-A-20361, Type I) has been substituted for Tuna, Lemon Pepper in Menu 21 of ACR-M-033."

"NOTE: PKG&QAP A-A-20361 with change 2, dtd 21 November 2012, is incorporated into the contract."

Page 4, Section C-2, A, Table I. Components – Continued, Delete "Nuts, Shelled, Roasted, Almonds (Unblanched), Flavored, (Barbeque)"

Page 7, Section C-2, A, Table I: Under "Granules/sprinkles, 2 gram packet" insert "Paperboard Sleeve" and under "Style A, Package1" insert "MIL-PRF-44073G".

Pages 9-13, Section C-2, A, Table III: Insert "Paperboard Sleeve" component into all menus except Menu #21. The Paperboard Sleeve is optional in Menu 21.

Page 5, Section C-2, A, Table I. Components – Continued;

After, "Pretzels, Nuggets," Delete "Plain, Salted and"

Page 12, Section C-2, C, TABLE III Contents, Menu #21; Delete "Tuna, lemon pepper" and insert "Chicken, garlic and herb".

Page 13, Table III – Continued, Menu 21

Delete: "Tuna, Lemon Pepper"

Insert: "Chicken Breast Fillet, Garlic and Herb Seasonings"

Page 13, Table III – Continued, Menu 24

Delete: "Turkey Nuggets"

Insert: "Beef Snacks, Strips"

Page 14 Section C-2, TABLE IV, Menu Distribution

Delete ", and barbeque almonds"

Page 17, Table V;

Insert: "Chicken Breast Fillet, Garlic and Herb Seasonings" with the French translation of: "Blancs de poulet à l'ail et aux fines herbes"

Page 18, Section D-3, A: Delete "16-11/16" and insert "15-5/8". Delete "10-1/4" and insert "9-9/16".

Pages 26-27, Section E, C (4), Table VIII: Delete defects 1, 101, and 203. Delete footnote 1/. Delete "or carton" in defect 3. Delete "uncartoned" in defect 4. Renumber defects and footnotes accordingly.

CONTINUED ON NEXT PAGE

Page 31, Section J, Military Specifications: Under "MIL-STD-3010" insert "MIL-PRF-44073G" and under "Test Procedure for Packaging Materials and Containers" insert "Packaging of Food in Flexible Pouches".

For the following menus use the corresponding graphics on the reverse of the Paperboard Sleeve:

Menu 1 Military Rations Are Good Performance Meals
Menu 2 Do's and Don'ts for Cold Weather Nutrition
Menu 3 Military Rations Are Good Performance Meals
Menu 4 Basic Heat Injury Prevention
Menu 5 Military Rations Are Good Performance Meals
Menu 6 Military Rations Are Good Performance Meals
Menu 7 Military Rations Are Good Performance Meals
Menu 8 Military Rations Are Good Performance Meals
Menu 9 What's In A MRE
Menu 10 Food, Water, and Exercise are Tactical Weapons
Menu 11 Military Rations Are Good Performance Meals
Menu 12 Military Rations Are Good Performance Meals
Menu 13 Military Rations Are Good Performance Meals
Menu 14 Military Rations Are Good Performance Meals
Menu 15 Military Rations Are Good Performance Meals
Menu 16 Military Rations Are Good Performance Meals
Menu 17 Military Rations Are Good Performance Meals
Menu 18 Military Rations Are Good Performance Meals
Menu 19 Military Rations Are Good Performance Meals
Menu 20 Military Rations Are Good Performance Meals
Menu 21 Military Rations Are Good Performance Meals
Menu 22 Military Rations Are Good Performance Meals
Menu 23 Military Rations Are Good Performance Meals
Menu 24 Military Rations Are Good Performance Meals

Tab 2, MIL-PRF-44073

Page 1, Section 1.1: Delete "cartons" and insert "sleeves".

Page 1, Text Box: Delete "ray.valvano@us.army.mil" and insert "melvin.l.carter6.civ@mail.mil".

Pages 5-7, Section 3.3: Replace "carton" with "sleeve" and replace "cartons" with "sleeves" throughout entire section.

Page 5, Section 3.3.1: Delete paragraph and insert "3.3.1 Sleeve design for 8 ounce size Gpouches (Type I, Style 1). The SSP sleeve shall be constructed in accordance with figure 6. When folded along the score lines located at the bottom of the sleeve, an open-ended carton shall result. Each SSP sleeve shall be securely sealed along the glue joint. The seal shall have a bond strength greater than the fiber tear of the paperboard."

Page 5, Section 3.3.2: Delete paragraph.

Page 6, Section 3.3.4: Delete paragraph and insert "Sleeve dimensions (Type I). The dimensions of the SSP sleeve shall be in accordance with figure 6."

Pages 5-6, Section 3.3: Renumber sections due to deletions.

Page 6, Section 3.4: Replace "carton" with "sleeve" and replace "cartons" with "sleeves" throughout entire section.

Page 6, Section 3.4.1: Delete paragraph.

Page 6, Section 3.4.2: Delete paragraph.

Page 6, Section 3.4: Renumber section numbers due to deletions.

Pages 6-7, Section 3.5: Replace "carton" with "sleeve" and replace "cartons" with "sleeves" throughout entire section.

CONTINUED ON NEXT PAGE

Page 7, Section 4.2: Delete "carton" and insert "sleeve, as applicable".

Page 11, Section 4.4: Delete "carton" and insert "sleeve" in header.

Page 11, Section 4.4, Sentence 1: Delete "carton assembly" and insert "accompanying sleeve" before "shall".

Page 12, Table III: Delete table and footnote and insert revised table and footnotes:

"TABLE III. Pouch and sleeve defects

Category			Defect
<u>Critical</u>	<u>Major</u>	<u>Minor</u>	
1			Tear, hole, or puncture through sleeve or open sleeve causing a hole in the pouch or obviously wet or stained sleeve due to leaking pouch. <u>1/</u>
	101		Tear or hole in sleeve exposing pouch to potential damage. <u>1/</u>
	102		Sleeve not clean. <u>1/</u>
	103		Bond strength in SSP sleeve glue joint is not greater than fiber strength of paperboard of sleeve.
	104		ISP pouch does not fit into the ISP sleeve. <u>2/</u>
		201	Tear or hole in sleeve not exposing pouch to potential damage. <u>1/</u>
		202	Color of sleeve not as specified.
		203	Labeling missing or incorrect or illegible.
		204	The ISP sleeve not closed as specified.
		205	Foreign odor.
		206	The SSP sleeve does not form an open-ended carton when correctly folded along the bottom scores.

1/ Type II only.

2/ Pouches with a folded end shall not be scored as a defect."

Page 15, Section 4.5.8.1, Line 2 and Line 8: Delete "After thermal processing, place pouches in paperboard cartons." and delete ", remove pouches from cartons".

Page 15, Section 4.5.8.2, Line 2 and Line 8: Delete "After thermal processing, package pouches in paperboard cartons." and delete ", remove pouches from cartons".

Page 16, Sections 4.5.8.3, 4.5.8.4, and 4.5.9: Replace "carton" with "sleeve" throughout sections.

Page 16, Sections 4.5.8.3, 4.5.8.4, and 4.5.9: Replace "carton" with "sleeve" throughout sections.

Page 18, Section 6.5.1: Delete paragraph and change "6.5.2" to "6.5.1".

Page 26, Figure 6: Delete Figure 6 and insert Figure 6, as follows:

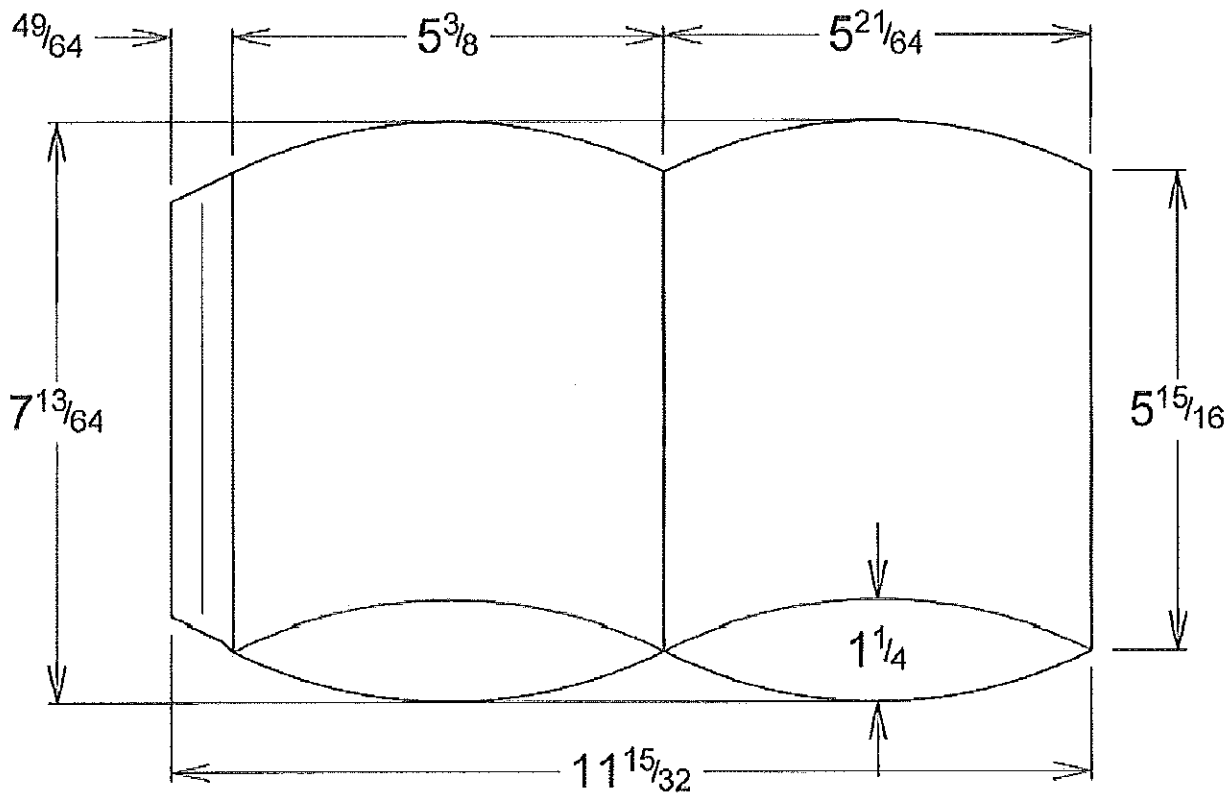

Figure 6. Sleeve Design

Tab 3, Section C – Description/Specification

Page 1 of 11, Section C, Part I

Delete "ACR-M-033" and insert "ACR-M-034, dated 5 September 2013, with change 01, dated 27 September 2013".

Page 1 of 11, Section C, Part II, Section **C-1 Description/Specification**.**ENTREES**

Delete in their entirety:

CHICKEN FAJITA,...

VEGETABLE LASAGNA,...

Insert the following:

BEEF, SHREDDED, IN BARBEQUE SAUCE, flex pg, min 227 gm, PCR-B-057, 8940-01-620-9418

VEGETABLE CRUMBLES WITH PASTA, in taco-style sauce, flex pg, min 227 gm, PCR-V-010, 8940-01-620-9458

Page 3 of 11, Section C, Part II, Section **C-1 Description/Specification**.**STARCHES AND SOUPS**

Delete in its entirety:

CONTINUED ON NEXT PAGE

REFRIED BEANS,...

SOUP, POTATO CHEDDAR,...

Insert:

BLACK BEANS,SEASONED, flex pg, min 142 gm, PCR-B-056, 8940-01-620-9405

Page 5 of 11, Section C, Part II, Section C-1 Description/Specification.

DESSERTS AND SNACKS

Insert the following:

PRETZELS,NUGGETS, Honey mustard and onion, 28 gm flex pg, A-A-20195, Type II, Style E, Flavor 2, 8940-01-621-5514

SNACK FOODS,CORN KERNELS, barbeque, min 57 gm flex pg, A-A-20195, Type VI, Flavor 2, 8940-01-621-5507

Page 7 of 11, Section C, Part II, Section C-1 Description/Specifcation.

CANDY

Insert the following:

CANDY,HARD,ROUND,CARAMEL, six pieces in flex pg, min 39 gm, A-A-20177, Type IV, Style C, Flavor 1, 8925-01-620-9401

OTHER ITEMS

Insert the following:

SLEEVE,FIBERBOARD,SSP, 7.203125 in by 5.375 in, for MRE, MIL-PRF-44073, Type I, 8970-01-622-8828

The following changes apply to PKG&QAP A-A-20361, Chicken Breast Fillets, Seasoned:

Section D-1, Packaging, page 2, line 1, after "pouch" delete "without the carton".

Section D-1, Packaging, page 2, After "Type I." insert "Note: Package C may be packaged with or without commercial packaging. If commercial packaging is used, the sleeve may be omitted. Package J shall be packaged without the fiberboard sleeve."

Section D-2, Labeling, bottom of page 2, After the NOTE, insert :

"Sleeves.

(1) When used for package C, the fiberboard sleeves shall be clearly printed on one of the largest panels with permanent black ink as follows:

Product name (7/32 to 9/32 inch block letters)

Ingredients

Net weight

Name and address of packer

USDA official inspection legend for the packer's plant

"Nutrition Facts" label in accordance with the Nutrition Labeling and Education Act (NLEA) and all applicable USDA regulations

(2) Military nutrition information entitled "Military Rations Are Good Performance Meals" shall be printed on the fiberboard sleeve's large panel opposite to the panel printed with the data in D-2,B (1) above. The information, provided by the contracting officer, shall be clearly printed with permanent black ink in an area no smaller than 4 inches by 5-1/4 inches.

(3) The sleeves shall be labeled with the following product name.

CONTINUED ON NEXT PAGE

CHICKEN BREAST FILLET, SEASONED, GARLIC AND HERB SEASONING"

Section E-6, Quality Assurance Provisions (Packaging and Packing Materials), page 8, after "(3) Pouch examination. The pouches shall be examined for the defects. . . . rejection of the lot" insert:

"(4) Examination of sleeve. When used for package C, the sleeve shall be examined for the defects listed in table III of MIL-PRF-44073 for Type I. The lot size shall be expressed in units of sleeves. The sample unit shall be one sleeve. The inspection level shall be S-3 and the AQL, expressed in terms of defects per hundred units, shall be 0.65 for major defects and 2.5 for minor defects."

The following changes apply to PCR-N-003A:

Page 5, § C-2, I Microbiological requirement

Delete in its entirety.

Page 14, § E-5, A, Table I, footnote Z/

Delete in its entirety.

Page 15, § E-5, B, (5) Salmonella testing

Delete in its entirety.

Page 16, § E-5, B, (6)

Delete in its entirety and insert:

"(6) Aflatoxin content testing. Compliance with aflatoxin testing requirements can be achieved in either of the two methods (A) or (B) described below. Note that method (B) requires certain conditions to be met.

Method (A): The sample to be analyzed shall be a composite of the finished product taken from a set of eight filled and sealed pouches which have been selected at random from the lot. The composited sample shall be prepared and analyzed in accordance of the OMA of AOAC International, method 991.31(HPLC) or 998.03, with preparation of the sample performed according to AOAC Official Method 977.16. Test results shall be reported to the nearest whole number. Government verification will be conducted through actual testing by a Government laboratory. Any result not conforming to the requirement shall be cause for rejection of the lot.

Method (B):

For prepackaged product (Types I, II, or III) received from a supplier that is not further processed or repackaged, the contractor will furnish a Certificate of Analysis that the aflatoxin in the finished product is not greater than 15 parts per billion (ppb). No additional testing is required. Results shall be reported to the nearest whole number.

For roasted peanuts, almonds, filberts, walnuts, and sunflower kernels received in bulk (to be used in finished product for Types I, II, or III), the contractor can accept a USDA certificate that the aflatoxin in the bulk ingredient lot is not greater than 15 ppb. (See the note at the bottom of this section.) If a USDA certificate does not accompany the ingredient bulk lot, the following alternate method of inspection may be used. The contractor shall have the bulk shipment sampled and tested by USDA. (Sampling of nut and kernel ingredients shall take place at the contractor location where the finished product will be placed into the pouch.) Steps (i) through (v) below apply to roasted peanut bulk lots. Step (vi) applies to almonds, filberts, walnuts, and sunflower kernels.

Three sets of representative, independently-drawn samples shall be submitted to the laboratory for testing – the number of sampling points and quantity of peanuts per sampling point to be determined using USDA procedures. Each of the three sets of samples shall be composited and respectively designated as test sample 1, test sample 2, and test sample 3.

Lots will be reported as negative for aflatoxin if test sample 1 has an aflatoxin level at or below 5 ppb. If test sample 1 is at or above 25 ppb the lot fails.

CONTINUED ON NEXT PAGE

If the aflatoxin level for test sample 1 is above 5 ppb and less than 25 ppb, test sample 2 may be analyzed. Test results for test sample 1 and 2 will be averaged. If the average aflatoxin level for test samples 1 and 2 is 10 ppb or less the lot will be reported as negative for aflatoxin, but fails if the aflatoxin level is at or above 20 ppb.

If the average value for test samples 1 and 2 is above 10 ppb but less than 20 ppb, test sample 3 may be analyzed. The results of test samples 1, 2 and 3 will be averaged. If the average aflatoxin level for test samples 1, 2, and 3 is 15 ppb or less the lot will be reported as negative for aflatoxin. If the average aflatoxin level for test samples 1, 2, and 3 is above 15 ppb the lot fails.

Bulk lots determined to be conforming for aflatoxin as evidenced by a USDA certificate, in accordance with the above procedures will be considered acceptable for use as ingredients as long as both the bulk and end item lots' identities have been preserved and the bulk lot has been maintained under acceptable conditions (i.e., between approximately 40°F to 50°F at low humidity). Results shall be reported to the nearest whole number. Bulk roasted peanuts with aflatoxin greater than 15 ppb shall not be used as ingredients.

Bulk ingredient lots of almonds, filberts, walnuts, and sunflower kernels shall be sampled using USDA/AMS sampling procedures to yield one or two 10-pound composites, depending on the lot size. The number of sample points accessed to create the 10-pound composite(s) will be based on the bulk lot size in pounds and USDA/AMS sampling procedures. The composites will be tested by the USDA/AMS laboratory using the designated methods, and reported on a USDA/AMS laboratory report. Bulk ingredient lots with aflatoxin results not greater than 15 ppb will be considered acceptable for use as long as the bulk and end item lots' identities have been preserved and the ingredients are maintained under acceptable conditions (i.e., between approximately 40°F to 50°F at low humidity). Results shall be reported to the nearest whole number. Bulk lots of almonds, filberts, walnuts, or sunflower kernels with aflatoxin greater than 15 ppb shall not be used as ingredients.

NOTE: A USDA Certificate of Analysis on roasted peanuts, almonds, filberts, walnuts, and sunflower kernels from the most recent crop year which have been kept in cold storage (between approximately 40°F to 50°F at low humidity) is acceptable. Contractor must attest to these storage conditions. If storage conditions for roasted peanuts are not established, a USDA certificate of analysis for aflatoxin on roasted peanuts will be considered current if not more than 30 days have elapsed since the date of the analysis."

The following changes apply to affected MRE™, USDA inspected entrée documents: PCR-A-005, PCR-B-020A, PCR-B-021A, PCR-B-029A, PCR-B-050, PCR-B-054, PCR-B-057, PCR-C-021A, PCR-C-027A, PCR-C-062, PCR-C-069, PCR-C-077, PCR-M-015, PCR-M-016, PCR-P-045, PCR-P-047, PCR-R-013, PCR-S-002 and PCR-S-018:

Section D-1: Delete paragraph in its entirety and insert "Product shall be filled into pouches and processed in accordance with MIL-PRF-44073, Packaging of Food in Flexible Pouches, Type I, Style 1."

Section D-2, A, (2): Delete "Official establishment number" or "Official inspection legend" depending on the document and insert "Official establishment number (optional)".

Section D-2, A: After "Time stamp..." insert "(3) USDA official inspection legend for the packer's plant".

Section D-2, B: Delete "Cartons" and insert "Paperboard sleeves".

Section D-2, B, (1): Delete "The cartons shall be clearly printed on one of the largest panels with permanent black ink as follows:" and insert "The sleeves shall be clearly printed on one of the panels with permanent black ink as follows: 1".

Section D-2, B, (1): Delete "Code (same as pouch code, see pouches) 1/ 2/ 3/" and "USDA official inspection legend for the packer's plant".

Section D-2, B, (1): Delete footnote 1/ in its entirety and insert "1/ With contracting officer approval, this information may be printed on the pouch in lieu of the paperboard sleeve."

Section D-2, B, (1): Delete footnote 2/ in its entirety.

Section D-2, B, (1): When present in the document, delete footnote 3/ in its entirety.

Section D-2, B, (2): Delete "...shall be printed on the entrée carton's large panel opposite to the panel printed with the data in D-2,B(1) above. The information, provided by the contracting officer, shall be clearly printed with permanent black ink in an area no smaller than 4-1/4 inches by 6-3/4 inches." and insert "...shall be printed on the entrée sleeve's panel opposite to the panel printed with the data in D-2,B(1) above, as applicable. The information, provided by the contracting officer, shall be clearly printed with permanent black ink in an area no smaller than 4 inches by 5-1/4 inches."

Section D-2, B, (3): When paragraph is present in the document, delete "The cartons shall be labeled with the following product name." and insert "The sleeves (or pouches, as applicable) shall be labeled with the following product name."

Section D-3, A: When present in the document, delete "Seventy-two pouches (of the same product) in cartons" and insert "Seventy-two pouches (of the same product)".

Section E-6, A, (4): Delete paragraph in its entirety and insert "Examination of sleeve. The sleeve shall be examined for the defects listed in table III of MIL-PRF-44073 for Type I. The lot size shall be expressed in units of sleeves. The sample unit shall be one sleeve. The inspection level shall be S-3 and the AQL, expressed in terms of defects per hundred units, shall be 0.65 for major defects and 2.5 for minor defects."

The following changes apply to affected MRE™, FDA inspected entrée documents: PCR-C-020A, PCR-P-036, PCR-R-012 and PCR-V-010:

Section D-1: Delete paragraph in its entirety and insert "Product shall be filled into pouches and processed in accordance with MIL-PRF-44073, Packaging of Food in Flexible Pouches, Type I, Style 1."

Section D-2, B: Delete "Cartons" and insert "Paperboard sleeves".

Section D-2, B, (1): Delete "The cartons shall be clearly printed on one of the largest panels with permanent black ink as follows:" and insert "The sleeves shall be clearly printed on one of the panels with permanent black ink as follows: 1/".

Section D-2, B, (1): Delete "Code (same as pouch code, see pouches) 1/ 2/ 3/".

Section D-2, B, (1): Delete footnote 1/ in its entirety and insert "1/ With contracting officer approval, this information may be printed on the pouch in lieu of the paperboard sleeve."

Section D-2, B, (1): Delete footnote 2/ in its entirety.

Section D-2, B, (1): Delete footnote 3/ in its entirety.

Section D-2, B, (2): Delete "...shall be printed on the entrée carton's large panel opposite to the panel printed with the data in D-2,B(1) above. The information, provided by the contracting officer, shall be clearly printed with permanent black ink in an area no smaller than 4-1/4 inches by 6-3/4 inches." and insert "...shall be printed on the entrée sleeve's panel opposite to the panel printed with the data in D-2,B(1) above, as applicable. The information, provided by the contracting officer, shall be clearly printed with permanent black ink in an area no smaller than 4 inches by 5-1/4 inches."

Section D-2, B, (3): When paragraph is present in the document, delete "...The cartons shall be labeled with the following product name." and insert "...The sleeves (or pouches, as applicable) shall be labeled with the following product name."

Section E-6, A, (4): Delete paragraph in its entirety and insert "Examination of sleeve. The sleeve shall be examined for the defects listed in table III of MIL-PRF-44073 for Type I. The lot size shall be expressed in units of sleeves. The sample unit shall be one sleeve. The inspection level shall be S-3 and the AQL, expressed in terms of defects per hundred units, shall be 0.65 for major defects and 2.5 for minor defects."

The following changes apply to affected MRE™, FDA inspected sides documents: PCR-B-056, PCR-P-011A, PCR-P-048, PCR-R-001A and PCR-S-019:

Section D-1: Delete paragraph in its entirety and insert "Product shall be filled into pouches and processed in accordance with MIL-PRF-44073, Packaging of Food in Flexible Pouches, Type I, Style 1."

Section D-2, A, (2): When present in the document, delete "Official establishment number (for example, EST-38)" and insert "Official establishment number (optional)".

Section D-2, B: Delete "Cartons" and insert "Paperboard sleeves".

Section D-2, B, (1): Delete "The cartons shall be clearly printed on one of the largest panels with permanent black ink as follows:" and insert "The sleeves shall be clearly printed on one of the panels with permanent black ink as follows: 1/ 2/".

Section D-2, B, (1): Delete "Code (same as pouch code, see pouches) 1/ 2/ 3/" and "USDA official inspection legend for the packer's plant", when present.

Section D-2, B, (1): Delete footnote 1/ in its entirety and insert "1/ With contracting officer approval, this information may be printed on the pouch in lieu of the paperboard sleeve."

Section D-2, B, (1): Delete footnote 2/ in its entirety and insert "2/ If printed on the sleeve, it shall be configured to fit alongside similar information for an accompanying pouched product. Identity of accompanying pouched product and approval of label design shall be obtained from the contracting officer."

Section D-2, B, (1): When present in the document, delete footnote 3/ in its entirety.

Section D-2, B, (2): Delete paragraph in its entirety.

Section D-2, B, (3): Delete "...The cartons shall be labeled..." and insert "...The sleeves (or pouches, as applicable) shall be labeled...". Renumber as D-2, B, (2).

Section D-3, A: When applicable, delete "Seventy-two pouches (of the same product) in cartons" and insert "Seventy-two pouches (of the same product)".

Section E-6, A, (4): Delete paragraph in its entirety and insert "Examination of sleeve. The sleeve shall be examined for the defects listed in table III of MIL-PRF-44073 for Type I. The lot size shall be expressed in units of sleeves. The sample unit shall be one sleeve. The inspection level shall be S-3 and the AQL, expressed in terms of defects per hundred units, shall be 0.65 for major defects and 2.5 for minor defects."

The following changes apply to affected MRE™, FDA Inspected fruits documents: PCR-A-001B, PCR-C-058 and PCR-F-002C:

Section D-1: Delete paragraph in its entirety and insert "Product shall be filled into pouches and processed in accordance with MIL-PRF-44073, Packaging of Food in Flexible Pouches, Type I." For PCR-F-002C, also insert "Applesauce shall be packaged in a side or center spout pouch."

Section D-2, A, (2): When present in the document, delete "Official establishment number (for example, EST-38)" and insert "Official establishment number (optional)".

Section D-2, B: Delete "Cartons" and insert "Paperboard sleeves".

Section D-2, B, (1): Delete "The cartons shall be clearly printed on one of the largest panels with permanent black ink as follows:" and insert "The sleeves shall be clearly printed on one of the panels with permanent black ink as follows: 1/ 2/".

Section D-2, B, (1): Delete "Code (same as pouch code, see pouches) 1/ 2/ 3/".

Section D-2, B, (1): Delete footnote 1/ in its entirety and insert "1/ With contracting officer approval, this information may be printed on the pouch in lieu of the paperboard sleeve."

Section D-2, B, (1): Delete footnote 2/ in its entirety and insert "2/ If printed on the sleeve, it shall be configured to fit alongside similar information for an accompanying pouched product. Identity of accompanying pouched product and approval of label design shall be obtained from the contracting officer."

Section D-2, B, (1): When present in the document, delete footnote 3/ in its entirety.

Section D-2, B, (2): Delete paragraph in its entirety.

Section D-2, B, (3): Delete "...The cartons shall be labeled..." and insert "...The sleeves (or pouches, as applicable) shall be labeled...". Renumber as D-2, B, (2).

Section D-3, A: When present in the paragraph, delete "...40 pounds of pouches in cartons..." and insert "...40 pounds of product..."

Section D-3, A: When present in the paragraph, delete "Seventy-two pouches (of the same product) in cartons" and insert "Seventy-two pouches (of the same product)".

Section E-6, A, (4): Delete paragraph in its entirety and insert "Examination of sleeve. When applicable, the sleeve shall be examined for the defects listed in table III of MIL-PRF-44073. The lot size shall be expressed in units of sleeves. The sample unit shall be one sleeve. The inspection level shall be S-3 and the AQL, expressed in terms of defects per hundred units, shall be 0.65 for major defects and 2.5 for minor defects."

The following changes apply to MIL-R-44398B, Ration Supplement, Flameless Heater, For Meal, Ready-to-Eat™:

The Warning and Operating Instruction sections of Drawing 6-1-8920 are replaced with the attached Drawing 6-1-8920, dated 24 October 2013.

The following documents are Incorporated:

MIL-PRF-32176, with change 01, dtd 1 November 2013

If the contractor incurs increased or decreased costs as a result of this modification the changed costs must be submitted to the ACO within 30 days. If nothing is submitted within 30 days, this modification will be considered finalized at no increased or decreased cost to the Government or the contractor. This does not waive any right of the ACO to review this mod and proceed with a formal finalization of this modification.