

INCH-POUND

A-A-52193G

February 24, 2015

SUPERSEDING

A-A-52193F

March 24, 2008

COMMERCIAL ITEM DESCRIPTION

FOOD CONTAINER, INSULATED, WITH INSERTS

The General Services Administration has authorized the use of this Commercial Item Description (CID) in preference to MIL-F-10870 for all federal agencies.

1. SCOPE AND CLASSIFICATION.

1.1 Scope. This CID covers plastic insulated food containers with removable insert pans having covers and gaskets for the transportation of hot or cold foods and liquids without spillage (see 6.1).

1.2 Classification. The food containers shall be of the following sizes, types, and classes (see 6.3):

Size 1 - 10 ¼ inches height (see 2.1)

Size 2 - 12 ¼ inches height (see 2.1)

Size 3 - 9 ¼ inches height (see 2.1)

Type I - ⅓ size, 6 inches deep, stainless steel insert pans with lids and gaskets (see 2.1.3)

Type II - ⅓ size, 6 inches deep, plastic insert pans with lids and gaskets (see 2.1.4)

Type III - Full size, 6 inches deep, plastic insert pans with lid and gasket (see 2.1.4)

Class 1 - Brown (Desert Sand)

Class 2 - Green (Olive)

1.3 CID based part identification number (PIN). A document based PIN to identify sizes and classes is included in section 6. This part identification number procedure is for government purposes and does not constitute a requirement for the contractor (see 6.5).

Beneficial comments, recommendations, additions, deletions, clarifications, etc. and any other data which may improve this document should be sent to: Defense Logistics Agency (DLA) Troop Support, ATTN: FTSA, 700 Robbins Avenue, Philadelphia, PA 19111-5092, or via E-mail: dscpsubswb@dla.mil. Since contact information can change, you may want to verify the currency of this address information using the ASSIST Online database at <https://assist.dla.mil>.

2. SALIENT CHARACTERISTICS.

2.1 Design. The insulated food container shall consist of a sealed insulated plastic body and lid. Lids shall be interchangeable between sizes 1 and 2. The exterior of the food container shall have an integral molded hand grasp handle which is continuous around the outside edge, and a minimum of four, over-the-center, plastic, lid locking latches. The food containers shall have the following maximum outside dimensions:

Size	Width (inches)	Length (inches)	Height (inches)
1	17 ³ / ₈	25 ¹ / ₈	10 ¹ / ₄
2	17 ³ / ₈	25 ¹ / ₈	12 ¹ / ₄
3	16 ³ / ₈	24 ¹ / ₂	9 ¹ / ₄

The food containers shall be stackable with an indentation in each outside corner of the lid to accommodate matching pads on the bottom of each container body. The stack ability interface shall be dimensionally the same for each size container. Size 1 and 2 containers shall be stackable when sizes are mixed in the same stack. The size 3 food container shall be nestable with a recessed bottom half of the body to accommodate matching insulated food containers. The nest ability interface shall be dimensionally the same for each size 3 container and shall reduce the stowage volume by more than or equal to 25% when two or more containers are nested together as compared to being stacked.

2.1.1 Body. The insulated container body shall consist of an inner and outer shell made of high density plastic, which is NSF/ANSI Standard 2, and Food and Drug Administration (FDA) food grade approved; also insulated to comply with the temperature performance specified in 2.2. The interior shall accommodate one full size, or three, one-third size, steam table pans, 6 inches deep. The size 1 container interior shall accommodate three tray pack cans (see figure 1). The size 2 container interior shall accommodate four tray pack cans (see figure 1). The size 3 container interior shall accommodate five tray pack cans (see figure 1). The body shall have a minimum of four plastic over-the-center latches. Latches shall be attached using stainless steel (American Iron and Steel Institute (AISI) types 304L or 316) machine screws threaded into the body. The latches shall be recessed from the outside edge of the body in both the latched and unlatched positions. Latches shall clamp the lid sufficiently to meet the thermal requirements specified in section 2.2.

2.1.2 Lid. The insulated lid shall be sealed, double walled, and made of high density plastic, which is FDA food grade approved, and insulated to comply with the temperature performance specified in 2.2. The top surface of the lid shall have recessed latching depressions to accommodate the latches installed on the body. The interior of the lid shall have special ribs to match the locations of the insert cover gaskets. When latched closed, the lid shall compress the insert cover gasket to form a liquid-tight seal on each insert pan.

A-A-52193G

2.1.3 Stainless steel insert pans type I. The insert pans (3 required) shall be 22 gauge (U.S. Standard Gauge shall apply to all sheet metal thicknesses) AISI type 304 stainless steel. Insert pans shall have NSF/ANSI Standard 2 listing. Each pan (6 by 11 $\frac{5}{8}$ inch inside dimensions) shall have a smooth bead around the top edge for easy cleaning and sealing. All inside corners shall be rounded and the flange ($\frac{1}{4}$ inch all around pan) shall have a minimum of $\frac{1}{16}$ inch flat, horizontal termination around the trimmed edge to strengthen the flange on the pan. Pans shall be supplied with a 20 gauge passivated stainless steel cover and molded gasket to seal the pan from liquid leakage. The gasket shall meet all FDA regulations for articles having repeated contact with food and shall function over a temperature range of -60°F to 212°F. The gasket shall not deteriorate as a result of exposure to repeated cleaning in a mechanical dishwashing environment. The gasket shall be removable from the cover for cleaning. The covers shall have a $\frac{1}{8}$ inch diameter raised air vent (open; unsealed) and a recessed lifting handle.

2.1.4 Plastic insert pans type II, and III. The insert pans shall be fabricated of a synthetic thermoplastic polymer. Insert pans shall have NSF/ANSI Standard #2 listing, and meet all FDA regulations for articles having repeated contact with food and shall function over a temperature range of -40°F to 375°F. Third size pans (5 $\frac{5}{8}$ by 11 $\frac{5}{8}$ by 6 inches deep inside dimensions), and full size pans (11 $\frac{1}{2}$ by 19 $\frac{1}{2}$ by 5 $\frac{5}{8}$ inches deep) shall have a smooth bead around the top edge for easy cleaning and sealing. All inside corners shall be rounded and the flange ($\frac{1}{4}$ inch all around pan) shall have a minimum of $\frac{1}{16}$ inch flat horizontal termination around the trimmed edge to strengthen the flange on the pan. Pans shall be supplied with a plastic cover that has an integrated gasket to prevent liquid leakage. The lid shall meet all FDA regulations for articles having repeated contact with food and shall function over a temperature range of -40°F to 210°F. The gasket shall not deteriorate as a result of exposure to repeated cleaning in a mechanical dishwashing environment.

2.1.5 Divide bar. The divider bar (1 required) shall be 12 $\frac{3}{4}$ inches long, color white. The divider bar for the size 1, 2 and 3 containers shall accommodate two tray pack cans (see figure 1). The divider bar shall be of sufficient strength to maintain the location and support two tray pack cans and function over a temperature range of 33°F to 180°F \pm 2°F.

2.2 Thermal performance.

2.2.1 Hot. When each insert pan (3) in the container is filled with water having a temperature of 180°F \pm 2°F, the water temperature shall decrease no more than 40°F when the container is exposed to an ambient temperature of -20°F \pm 5°F for 4 hours. Prior to testing, the container shall be preheated by filling only the three insert pans with 180°F \pm 5°F water, installing the pan covers and container lid, and holding for 10 minutes. Refill insert pans with water having the specified temperature. Test as specified above.

2.2.2 Cold. When each insert pan (3) in the container is filled with water having a temperature of 33°F \pm 2°F, -0°F, the water temperature shall increase no more than 12°F when the container is

A-A-52193G

exposed to an ambient temperature of $120^{\circ}\text{F} \pm 5^{\circ}\text{F}$ for 4 hours. Prior to testing, the container shall be pre-chilled by filling only the three pans with a mixture of ice and water, installing the pan covers and container lid, and holding for 10 minutes. Empty all ice. Refill insert pans with water having the specified temperature. Test as specified above.

2.3 Codes and standards. The insulated food containers shall comply with NSF/ANSI Standard 2.

2.4 Mold identification marking (“government unique” requirement see 6.6). When specified (see 6.3), the insulated food container shall be furnished with identification information molded or embossed into the surface of the container body. The information required shall be as follows:

“National Stock Number _____
Manufacturer’s Name _____
Manufacturer’s Address _____
Manufacturer’s Model Number _____.”

2.5 Finish. The surface of the finished container shall comply with the finish requirements of NSF/ANSI Standard 2.

2.6 Workmanship. The insulated food containers shall be complete, clean and free of scratches, dents, breaks, sharp edges and corners, and deformities. All components and assemblies shall be free of dirt and other extraneous materials. Burrs, slivers, rough die, tool, and grinding marks, dents, and cracks shall be unacceptable. Threaded fasteners shall not be missing, broken, cracked, or stripped of threads. There shall be no defects affecting serviceability, durability, operation, performance, or appearance.

2.7 Classes (“government unique” requirement) (see 1.2, 6.3, and 6.6). The body and lids of the sizes of insulated food containers shall be either Brown (class 1) conforming to FED-STD-595, Color Nos. 20313, 30313, or 30279; or Green (class 2) conforming to Fed-STD-595, Color Nos. 24097, 34094, 34095, 34096, or 34097. Food containers of a specific lot shall not exhibit any variation in shade from the specific color selected and specified in the contract for that production lot.

2.8 Metric products. Products manufactured to metric (SI) dimensions will be considered on an equal basis with those manufactured using inch-pound units, provided they fall within the tolerances specified using conversion tables contained in the latest revision of IEEE/ASTM SI10, and all other requirements of this CID are met. If a product is manufactured to metric (SI) dimensions and those dimensions exceed the tolerances specified in inch-pound units, a request should be made to the contracting officer to determine if the product is acceptable. The contracting officer may accept or reject the metric product.

3. REGULATORY REQUIREMENTS.

3.1 Recovered materials. The offeror/contractor is encouraged to use recovered materials to the maximum extent practicable, in accordance with paragraph 23.403 of the Federal Acquisition Regulation (FAR). Recycled or reclaimed materials may be used in the construction of the equipment described herein. Recycled and reclaimed materials shall consist of previously used material, which has been reprocessed to become a source of new raw material. Under no conditions or circumstances shall the contractor submit to the Government for acceptance reconditioned or rebuilt components as a part of the equipment described herein.

4. PRODUCT CONFORMANCE PROVISIONS.

4.1 Product conformance. The products provided shall meet the salient characteristics of this CID, and (except for any government unique requirements specified), conform to the producer's own drawings, specifications, standards and quality practices, and be the same product offered for sale in the commercial marketplace. The Government reserves the right to require proof of such conformance prior to first delivery and thereafter as may be otherwise provided for under the provisions of the contract.

4.2 Market acceptability. The following market acceptability criteria are necessary to document the quality of the products to be provided under this CID:

- a. The company producing the product meeting the requirements of this CID must have been producing these items for at least 2 years.
- b. The company must have sold at least 1000 units of the product meeting the requirements of this CID in the commercial or government marketplace over the last 2 years.

4.3 Inspection requirements. Bid samples may be required for CID items when necessary to assure product quality. In general, first article testing should not be required. First article testing may only be required for those items produced on demand, which are customized. Detailed procedures on inspection requirements or sampling in a CID should be minimized and used only when no other method for assuring quality is acceptable.

4.4 NSF International standard compliance. Prior to approval of the first shipment, the contractor shall provide satisfactory evidence to the contracting officer (or his authorized representative) that the food containers conform to the applicable requirements of NSF/ANSI Standard 2. Acceptable evidence of meeting the requirements of NSF/ANSI Standard 2 shall be a listing in the current edition of the NSF International "Listing of Food Service Equipment" and display of the NSF International mark on the finished product, or a certified test report from a

recognized independent laboratory acceptable to medical authority of the Government indicating that the item complies with the applicable NSF International requirement.

4.5 Warranty. Unless otherwise specified in the contract, the manufacturer's standard commercial warranty shall apply.

5. PACKAGING.

5.1 Packaging. Preservation, packing, and marking requirements shall be as specified in the contract or purchase order (see 6.3).

6. NOTES.

6.1 Intended use. The insulated food containers are intended for use in transporting either hot (160°F to 180°F) or cold (35°F to 40°F) foods to remote feeding sites. Ambient temperatures range between -20°F to 120°F.

6.2 Commercial item certification. When this CID is used for procurement, the commercial item certification clause must appear in the solicitation.

6.3 Acquisition requirements. Acquisition documents must specify the following:

- a. Title, number, and date of this document.
- b. Size, type, and class of container required (see 1.2, 2.1, and 2.7).
- c. When molded identification marking is required (see 2.4).
- d. Packaging requirements (see 5.1).

6.4 Sources of documents.

6.4.1 Sources of Government documents. Copies of military and federal documents are available from: ASSIST Online (<https://assist.dla.mil>) or ASSIST Quick Search (<http://quicksearch.dla.mil>) or from the Standardization Documents Order Desk, DLA Document Services, Building 4D, 700 Robbins Avenue, Philadelphia, PA 19111-5094.

6.4.2 Sources for non-government association documents are as follows:

SI10 - Standard for Use of the International Systems of Units (SI): the Modern Metric System may be obtained from: Institute of Electrical and Electronics Engineers, Inc., 305 East 47th Street, New York, NY 10017; or to the American Society for Testing and Materials, 100 Barr Harbor Drive, West Conshohocken, PA 19428-2959, or online at www.astm.org.

Copies of NSF/ANSI Standard 2 are available from: NSF International, P.O. Box 130140, 789 N. Dixboro Road, Ann Arbor, MI 48113-0140, or online at www.nsf.org.

6.5 Part identification number (PIN). The following part identification numbering procedure is for government purposes and does not constitute a requirement for the contractor. The PIN shall be constructed as follows:

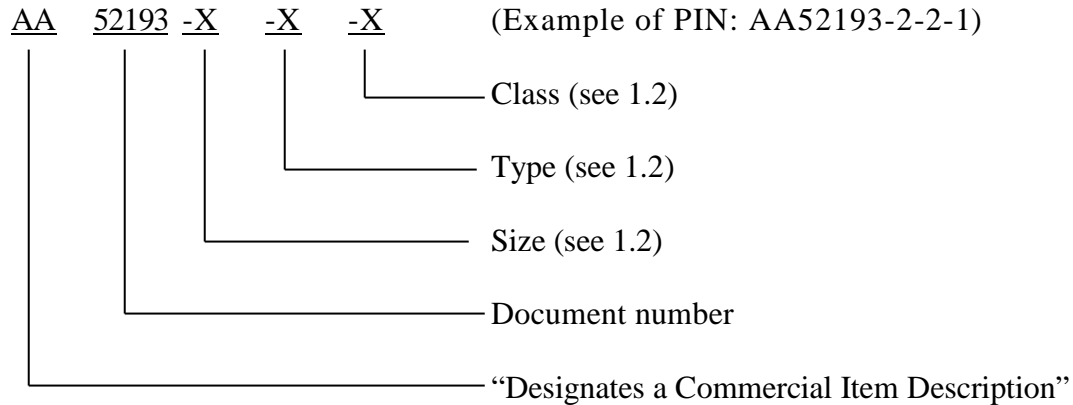

6.6 “Government unique” requirements. Whenever a "government unique" requirement is included in the title of a paragraph under "Salient Characteristics", it means that the requirement is something that is not normally offered to the commercial marketplace by the manufacturer(s) of the subject commodity.

6.7 Sources of supply. The manufacturer whose product, when modified to the “Government unique requirements” is known to meet the CID requirements, is listed below. However, competition is not limited to this company:

Cambro USA
5801 Skylab Road
Huntington Beach, CA 92647-2056
(800) 833-3003

A-A-52193G

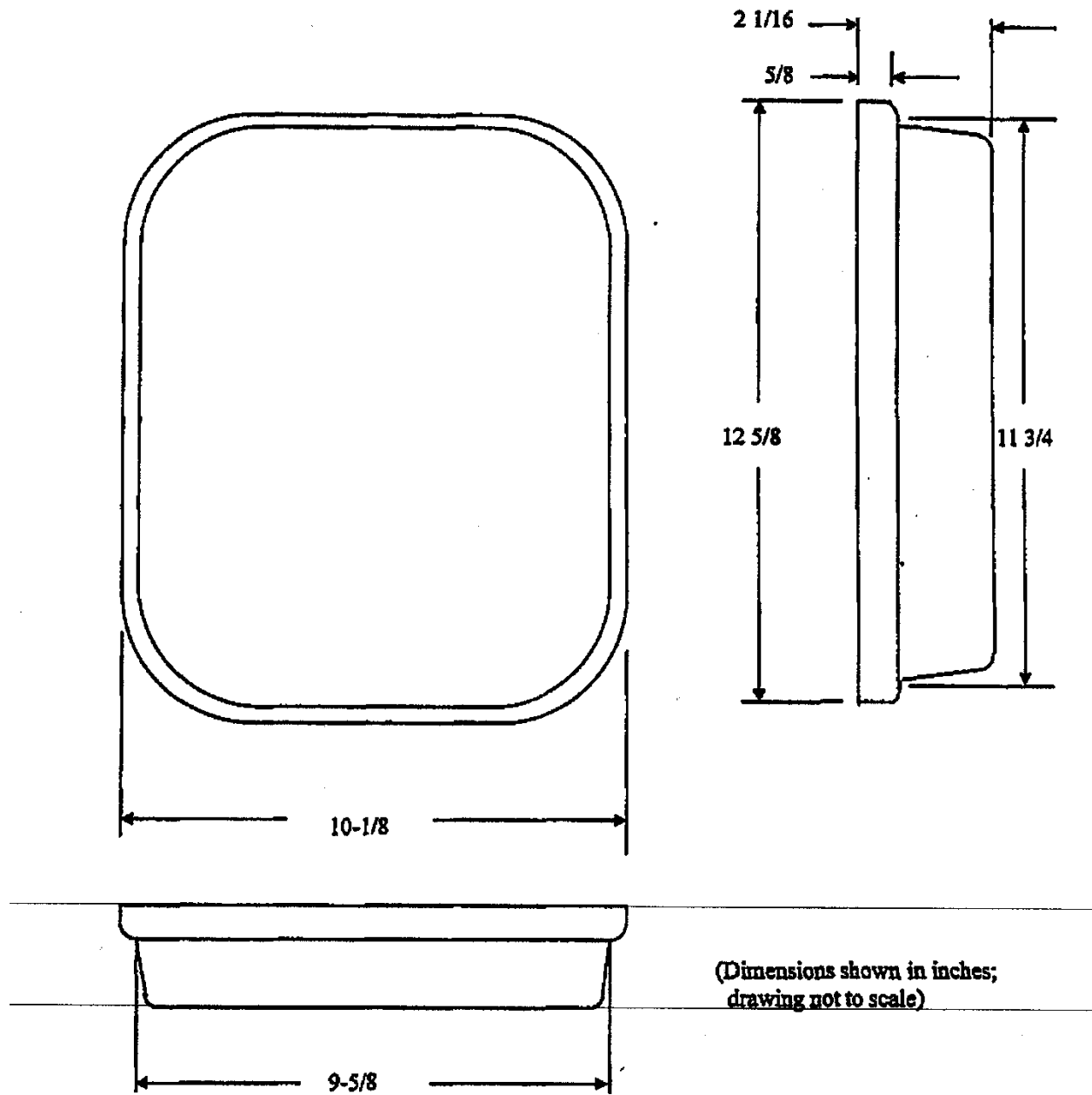

Tray Pack Can

Figure 1

A-A-52193G

MILITARY INTEREST:

CIVIL AGENCY COORDINATION ACTIVITY:

Custodians:

GSA - FAS

Army - GL

Air Force - 99

Navy - SA

Preparing Activity:

Review activities:

DLA - SS

Army - QM1, MD1

Air Force - 35, 84

Navy - MC

(Project 7330-2015-001)

NOTE: The activities listed above were interested in this document as of the date of this document. Since organizations and responsibilities can change, you should verify the currency of the information above using the ASSIST Online database at <https://assist.dla.mil/>.