

SECTION C

This document covers chocolate protein drink powder packaged in a flexible pouch for use by the Department of Defense as a component of operational rations.

C-1 ITEM DESCRIPTION

PCR-C-082B, CHOCOLATE PROTEIN DRINK POWDER, PACKAGED IN A FLEXIBLE POUCH, SHELF STABLE

Flavors.

- Flavor I - Chocolate
- Flavor II - Chocolate hazelnut

C-2 PRODUCT REQUIREMENTS

A. Product standard. A sample shall be subjected to first article (FA) or product demonstration model (PDM) inspection as applicable, in accordance with the tests and inspections of Section E of this Product Contract Requirements (PCR) document. The approved sample shall serve as the product standard. Should the contractor at any time plan to or actually produce the product using different raw material or process methodologies from the approved product standard, which result in a product noncomparable to the product standard, the contractor shall submit a replacement FA or PDM for approval. In any event, all product produced must meet all requirements of this document including product standard comparability.

B. Shelf life. The packaged product shall meet the minimum shelf life requirement of 36 months at 80°F.

C. Powdered product.

(1) Appearance. The finished product shall be chocolate protein drink powder. The chocolate protein drink powder shall be a uniform blend of dry homogenous ingredients and shall be a medium to dark brown color. The finished product shall be free from foreign materials.

(2) Odor. The packaged food shall be free from foreign odors.

a. Flavor I. The packaged food shall have an odor of semi-sweet chocolate and sweet dairy.

b. Flavor II. The packaged food shall have an odor of hazelnut, semi-sweet chocolate and sweet dairy.

(3) Texture. The chocolate protein drink powder shall be free flowing and have no discernable lumps that cannot be broken apart under light pressure.

D. Net weight. The net weight of an individual pouch shall be not less than 2.5 ounces (71 grams).

E. Hydrated product. The chocolate protein drink powder, when hydrated according to directions for use, shall dissolve within 2 minutes of constant shaking.

(1) Appearance. The hydrated chocolate protein drink shall be a uniform medium to dark brown color and have no discernable lumps.

(2) Odor and flavor. The hydrated product shall be free from foreign odors and flavors.

a. Flavor I. The hydrated product shall have a sweet cocoa odor and a semi-sweet chocolate and sweet dairy flavor.

b. Flavor II. The hydrated product shall have a moderate hazelnut, semi-sweet chocolate and slightly sweet dairy odor and flavor.

(3) Texture.

a. Flavor I. The hydrated product shall be smooth, creamy, and have a moderately thick consistency with no discernable lumps or chalkiness.

b. Flavor II. The hydrated product shall be smooth, creamy, and have a slightly thick consistency with no discernable lumps or chalkiness.

F. Palatability and overall appearance. The finished product shall be equal to or better than the approved product standard in palatability and overall appearance.

G. Analytical requirements.

- (1) Protein. The protein content shall be not less than 16 percent.
- (2) Moisture.
 - a. Flavor I. The moisture content shall be not greater than 3.0 percent.
 - b. Flavor II. The moisture content shall be not greater than 5.0 percent.
- (3) Vitamin C. The Vitamin C content shall be not less than 35 mg per 100 grams of product.
- (4) Vitamin D3. The Vitamin D3 content shall be not less than 120 International Units (IU) and not greater than 250 IU per 100 grams of product.

H. Microbiological requirements.

- (1) Aerobic plate count. The aerobic plate count shall be not greater than 50,000 Colony Forming Units (CFU) per gram in four of five samples and not greater than 75,000 CFU per gram in any individual sample.
- (2) Escherichia coli (E. coli) count. *E. coli* shall have less than 10 CFU per gram or less than 3 Most Probable Number (MPN) per gram, where findings indicate zero colonies CFU per plate or zero tubes producing gas for MPN.
- (3) Salmonella. The *Salmonella* test shall be negative for each of five pouches tested per production lot.

I. Product formulation and ingredients. The following formulas shall be used. Ingredient suppliers and available specific ingredients may change (companies bought out, part numbers change, ingredients no longer supplied, etc.). Any changes in ingredients or formula will need to be approved by Combat Capabilities Development Command-Soldier Center (FCDD-SCC-EMR).

(1) Flavor I, Chocolate.

<u>Ingredient</u>	<u>Percent by weight</u>
Sugar, white granulated	48.21
Maltodextrin <u>1/</u>	17.53
Dutched Cocoa powder <u>2/</u>	13.15
Whey protein isolate <u>3/</u>	12.05
Sodium caseinate <u>4/</u>	4.38
Chocolate flavor, natural and artificial <u>5/</u>	3.29
Thickening agent <u>6/</u>	0.88
Salt, iodized	0.44
Vitamin premix <u>7/</u>	0.07

1/ Maltodextrin shall have a dextrose equivalent range of 9.0 to 12.0 and moisture content not greater than 6.0 percent. The bulk density shall be 21 pounds per cubic feet “Maltrin QD M500” from Grain Processing Corporation, 1600 Oregon Street, Muscatine, IA 52761-1494 or equivalent.

2/ “Gerken Russett Plus (10 to 12 percent fat)” from Cargill Inc., PO Box 9300 Minneapolis, MN 55440-9300.

3/ “SureProtein™ Whey Protein Isolate #895” Fonterra (USA) Inc., 9525 West Bryn Mawr Avenue, Suite 700, Rosemont, IL 60018.

4/ “Sodium Caseinate #180” Fonterra (USA) Inc., 9525 West Bryn Mawr Avenue, Suite 700, Rosemont, IL 60018.

5/ “Chocolate Flavor Powder #79166-LM-R3” Blue Pacific Flavors, 1354 Marion Court, City of Industry, CA 91745-2418.

6/ Thickening Agent shall be a combination of cellulose gum, xanthan gum, and carrageenan gum. “PRETESTED® Colloid ULTRASMMOOTH” TIC Gums, 10552 Philadelphia Road, White Marsh, MD 21162 or equivalent.

7/ Vitamin premix shall include Vitamin C and Vitamin D3 and shall be made to ensure compliance with requirements as stated in C-2, G(3) and (4).

(2) Flavor II, Chocolate hazelnut.

<u>Ingredient</u>	<u>Percent by weight</u>
Sugar, white granulated	31.23
Maltodextrin <u>1/</u>	31.30
Whey protein isolate <u>2/</u>	13.30
Powdered creamer <u>3/</u>	8.60
Dutched cocoa powder <u>4/</u>	7.80
Instantized micellar casein (82% pure)	3.90
Chocolate flavor <u>5/</u>	1.60
Hazelnut flavor <u>6/</u>	1.60
Thickening agent <u>7/</u>	0.60
Vitamin premix <u>8/</u>	0.07

1/ Maltodextrin shall have a dextrose equivalent range of 9.0 to 12.0 and moisture content not greater than 6.0 percent. The bulk density shall be 21 pounds per cubic feet “Maltrin QD M500” from Grain Processing Corporation, 1600 Oregon Street, Muscatine, IA 52761-1494 or equivalent.

2/ “SureProtein™ Whey Protein Isolate #895” Fonterra (USA) Inc., 9525 West Bryn Mawr Avenue, Suite 700, Rosemont, IL 60018.

3/ Creamer shall have a moisture content not greater than 3.0 percent. “Sensory Effects QuIC Creamer 5205”, 136 Fox Run Drive, Defiance, OH 43512 or equivalent.

4/ Dutched cocoa powder #208056 from Blommer Chocolate Company, 600 West Kinzie St, Chicago, IL 60610 or equivalent.

5/ “Michaelok® Natural and Artificial Dark Chocolate Flavor #1397” Tastepoint by IFF, 7800 Holstein Avenue, Philadelphia, PA 19153.

6/ “Natural & Artificial Chocolate Hazelnut Flavor #35632” Tastepoint by IFF, 7800 Holstein Avenue, Philadelphia, PA 19153 or equivalent.

7/ Thickening Agent shall be a combination of cellulose gum, xanthan gum, and carrageenan gum. “PRETESTED® Colloid ULTRASMMOOTH” TIC Gums, 10552 Philadelphia Road, White Marsh, MD 21162 or equivalent.

8/ Vitamin premix shall include Vitamin C and Vitamin D3 and shall be made to ensure compliance with requirements as stated in C-2, G(3) and (4).

SECTION D

D-1 PACKAGING

A. Packaging. A net weight of 2.5 ounces (71 grams) of product shall be filled into a pouch. The pouch is to be used as a package and a hydrating pouch for the beverage.

(1) Flat interlocking closure pouch.

a. Pouch material. The pouch shall be fabricated from 0.002 inch thick ionomer or polyethylene film laminated or extrusion coated to 0.00035 inch thick aluminum foil which is then bonded to 0.0005 inch thick polyester. Tolerances for thickness of plastic films shall be plus or minus 20 percent and tolerance for foil layer shall be plus or minus 10 percent. The material shall show no evidence of delamination, degradation, or foreign odor when heat sealed or fabricated into pouches. The material shall be suitably formulated for food packaging and shall not impart an odor or flavor to the product. The complete exterior surface of the pouch shall be uniformly colored in the range of 20219, 30219, 30227, 30279, 30313, 30324, or 30450 of SAE AMS -STD-595, Colors Used in Government Procurement.

b. Pouch construction. The pouch shall be a flat design preformed or vertical form-fill-seal pouch with an interlocking closure. The design and dimensions shall be as specified in figure 1. The pouch shall be made by heat sealing the sides and top of the pouch with 3/8 (+1/8, -1/4) inch wide seals. The pouch shall exhibit no rupture or seal separation greater than 1/16 inch when tested for internal pressure resistance. The interlocking closure of the pouch shall not leak more than 15 ml. A tear nick or notch shall be provided on one or two opposite edges of the pouch above the interlocking closure to facilitate opening of the filled and sealed pouch. A 1/8 inch wide lip may be incorporated at the open end of the pouch.

c. Pouch filling and sealing. Product shall be inserted into the pouch and the filled pouch shall be sealed with a 1/8 to 1 inch wide heat seal. The closure seal shall be applied not more than 1/2 inch from the open end of the pouch. The closure seal shall be free of foldover wrinkles or entrapped matter that reduces the effective closure seal width to less than 1/16 inch. Seals shall be free of impression or design on the seal surface that would conceal or impair visual detection of seal defects. The average seal strength shall be not less than 6 pounds per inch of width and no individual specimen shall have a seal strength of less than 5 pounds per inch of width. Alternatively, the filled and sealed pouch shall exhibit no rupture

or seal separation greater than 1/16 inch or seal separation that reduces the effective closure seal width to less than 1/16 inch when tested for internal pressure resistance.

D-2 LABELING

A. Pouches. Each pouch shall be correctly and legibly labeled. Printing ink shall be permanent black ink or other dark contrasting color which is free of carcinogenic elements. The label shall contain the following information:

- (1) Name and flavor of product (letters not less than 1/8 inch high)
- (2) Ingredients
- (3) Date 1/
- (4) Net weight
- (5) Name and address of packer
- (6) "Nutrition Facts" label in accordance with the Nutrition Labeling and Education Act (NLEA) and all applicable FDA regulations

(7) Directions:

Allow water just chemically purified to stand 30 minutes before adding to powder. Tear pouch at notch. Open zipper, add 8 ounces of cold water (about 1/3 canteen cup) to fill line. Close zipper, shake to mix. Consume promptly (within 1 hour).
Single use only.

Fill line: A fill line (not less than 1/32 inch thick, not less than 2 inches long and centered) shall be placed on the pouch/label for 8 ounce fill at 5-3/4 ± 1/4 inches from the inside edge of the bottom closure seal.

1/ Each pouch shall have the date of pack noted by using a four digit code beginning with the final digit of the current year followed by the three digit Julian day code. For example, 14 February 2020 would be coded as 0045. The Julian day code shall represent the day the product was packaged into the pouch. Sub-lotting (when used) shall be represented by an alpha character immediately following the four digit Julian code.

D-3 PACKING

A. Packing. Not more than 40 pounds of product shall be packed in a fiberboard shipping box constructed in accordance with style RSC-L of ASTM D5118/D5118M, Standard Practice for Fabrication of Fiberboard Shipping Boxes. The fiberboard shall conform to type CF, class D, variety SW, minimum burst grade 200 or ECT 32 of ASTM D4727/D4727M,

Standard Specification for Corrugated and Solid Fiberboard Sheet Stock (Container Grade) and Cut Shapes. Each box shall be closed in accordance with ASTM D1974/D1974M, Standard Practice for Methods of Closing, Sealing, and Reinforcing Fiberboard Boxes.

D-5 MARKING

A. Shipping containers. Shipping containers shall be marked in accordance with DLA Troop Support Form 3556, Marking Instructions for Boxes, Sacks, and Unit Loads of Perishable and Semiperishable Subsistence.

SECTION E INSPECTION AND ACCEPTANCE

The following quality assurance criteria, utilizing ANSI/ASQ Z1.4, Sampling Procedures and Tables for Inspection by Attributes, are required. Unless otherwise specified, single sampling plans indicated in ANSI/ASQ Z1.4 will be utilized. When required, the manufacturer shall provide the Certificate(s) of Conformance to the appropriate inspection activity. Certificate(s) of Conformance not provided shall be cause for rejection of the lot.

A. Definitions.

(1) Critical defect. A critical defect is a defect that judgment and experience indicate would result in hazardous or unsafe conditions for individuals using, maintaining, or depending on the item; or a defect that judgment and experience indicate is likely to prevent the performance of the major end item, i.e. the consumption of the ration.

(2) Major defect. A major defect is a defect, other than critical, that is likely to result in failure, or to reduce materially the usability of the unit of product for its intended purpose.

(3) Minor defect. A minor defect is a defect that is not likely to reduce materially the usability of the unit of product for its intended purpose, or is a departure from established standards having little bearing on the effective use or operation of the unit.

B. Classification of inspections. The inspection requirements specified herein are classified as follows:

(1) Product standard inspection. The first article or product demonstration model shall be inspected in accordance with the provisions of this document and evaluated for appearance, odor, flavor and texture. Any failure to conform to the product requirements or any appearance or palatability failure shall be cause for rejection of the lot.

PCR-C-082B
25 July 2019
SUPERSEDING
PCR-C-082A
29 May 2015

(2) Periodic review evaluation. The approved first article or product demonstration model shall be used as the product standard for periodic review evaluations. All food components that are inspected by the USDA shall be subject to periodic review sampling and evaluation. The USDA shall select sample units during production of contracts and submit them to the following address for evaluation:

DEPARTMENT OF THE ARMY
FCDD-SCC-EMR
COMBAT CAPABILITIES DEVELOPMENT COMMAND-SOLDIER CENTER
10 GENERAL GREENE AVENUE
NATICK, MA 01760-5056

One lot shall be randomly selected during each calendar month of production or as otherwise specified in the contract. Three (3) sample units shall be randomly selected from that one production lot. The three (3) sample units shall be shipped to Natick within five (5) working days from the end of the production month from which they are randomly selected and upon completion of all USDA inspection requirements. The sample units will be evaluated for overall quality against the current first article or product demonstration model.

(3) Conformance inspection. Conformance inspection shall include the product examinations/tests and methods of inspection cited in this section.

E-5 QUALITY ASSURANCE PROVISIONS (PRODUCT)

A. Product examination. The finished product shall be examined for compliance with the product requirements specified in Section C of this Product Contract Requirements document utilizing the double sampling plans indicated in ANSI/ASQ Z1.4. The lot size shall be expressed in pouches. The sample unit shall be the contents of one pouch. The inspection level shall be S-3 and the acceptable quality level (AQL), expressed in terms of defects per hundred units, shall be 1.5 for major defects and 4.0 for minor defects. Defects and defect classifications are listed in table I.

TABLE I. Product defects 1/ 2/

Category		Defect
<u>Major</u>	<u>Minor</u>	
		<u>Powdered product</u>
		<u>General</u>
101		Not flavor as specified.
		<u>Appearance</u>
	201	Product not a uniform blend of dry homogenous ingredients.
	202	Product not a medium to dark brown color.
		<u>Odor</u>
102		Flavor I odor not semi-sweet chocolate or not sweet dairy.
103		Flavor II odor not hazelnut or not semi-sweet chocolate or not sweet dairy.
		<u>Texture</u>
	203	Product not free flowing.
	204	Presence of discernable lumps. <u>3/</u>
		<u>Net weight</u>
	205	Net weight of an individual pouch less than 2.5 ounces (71 grams).

TABLE I. Product defects 1/ 2/ - Continued

Category		Defect
<u>Major</u>	<u>Minor</u>	
<u>Hydrated product</u> <u>4/</u>		
<u>Appearance</u>		
	206	The hydrated chocolate protein drink not a uniform medium to dark brown color.
	207	Hydrated product has discernable lumps.
<u>Odor and flavor</u>		
104		Flavor I does not have a sweet cocoa odor or does not have a semi-sweet chocolate flavor or does not have a sweet dairy flavor.
105		Flavor II does not have a moderate hazelnut or does not have a semi-sweet chocolate or does not have a slightly sweet dairy odor and flavor.
<u>Texture</u>		
	208	Flavor I not smooth or not creamy or not a moderately thick consistency.
	209	Flavor II not smooth or not creamy or not a slightly thick consistency.
	210	Hydrated product has discernable lumps or chalkiness.

1/ Presence of any foreign materials such as, but not limited to dirt, insect parts, hair, glass, wood, or metal, or any foreign odors or flavors such as, but not limited to burnt, scorched, rancid, sour, stale, musty or moldy shall be cause for rejection of the lot. Foreign flavors not applicable to powdered product.

2/ Finished product not equal to or better than the approved product standard in palatability and overall appearance shall be cause for rejection of the lot. Palatability not applicable to powdered product.

3/ Lumps that do not fall apart under light pressure shall be scored as a defect.

4/ Prior to conducting the hydrated product examination, the chocolate protein drink powder shall be hydrated per label instructions. Product that does not fully dissolve within 2 minutes with constant stirring or shaking shall be cause for rejection of the lot.

B. Methods of inspection.

(1) Shelf life. The contractor shall provide a Certificate of Conformance that the product has a 36 month shelf life when stored at 80°F. Government verification may include storage for 6 months at 100°F or 36 months at 80°F. Upon completion of either storage period, the product will be subjected to a sensory evaluation panel for appearance and palatability and must receive an overall score of 5 or higher based on a 9 point quality scale to be considered acceptable.

(2) Net weight. The net weight of the filled and sealed pouches shall be determined by weighing each sample on a suitable scale tared with a representative empty pouch. Results shall be reported to the nearest 0.1 ounce or to the nearest 1 gram.

(3) Analytical. The sample to be analyzed shall be a composite of eight filled and sealed pouches which have been selected at random from the lot. The composite sample shall be prepared and analyzed in accordance with the following methods of the Official Methods of Analysis (OMA) of AOAC International:

<u>Test</u>	<u>Method Number</u>
Protein	930.29A, 991.20 or 2001.11
Moisture	925.45A <u>1/</u>
Vitamin C	984.26 or 967.21 <u>2/</u>
Vitamin D3	2002.05, 2011.12 or 2011.13 <u>2/</u>

Test results for protein shall be reported to the nearest 1 gram. Test results for the moisture shall be reported to the nearest 0.1 percent. Government verification will be conducted through actual testing by a Government laboratory. Any result not conforming to the analytical requirement shall be cause for rejection of the lot.

1/ The temperature-time cycle for moisture analysis shall be modified by using a temperature of 70°C for 16 hours at a pressure of not more than 100 mm of mercury.

2/ Tests will be conducted for Vitamin C and for Vitamin D3 on the first production lot of a contract cycle. USDA will perform the verification testing and obtain a copy of the formulation used in the production of that lot. A Certificate of Conformance (CoC) for

nutrient content for Vitamin C and Vitamin D3 will be provided on all future lots produced using the same formulation. If the formula is changed or a new contract starts, then another set of tests shall be conducted by USDA, for Vitamin C and Vitamin D3, and USDA will obtain a copy of the formulation.

(4) Microbiological testing. The finished product shall be tested for microbiological activity. Five filled and sealed pouches shall be selected at random from the lot regardless of lot size. The finished product shall be individually tested for microbiological activity in accordance with the Official Methods of Analysis (OMA) of the AOAC International or the Food and Drug Administration (FDA) Bacteriological Analytical Manual (BAM). For Aerobic plate count the average result for all composites tested must comply as provided in C-2, H(1). For *E. coli* and *Salmonella*, results for each sample must comply as provided respectively in C-2, H(2) and (3). Any result not conforming to the microbiological requirements shall be cause for rejection of the lot.

<u>Test</u>	<u>Method Number</u>
Aerobic plate count	966.23 or 990.12
<i>E. coli</i>	966.24, 991.14, 992.30 or FDA's BAM, Chapter 4, sections C & F
<i>Salmonella</i>	967.26, 967.28, 986.35, 991.13, 2003.09, 2004.03, 2013.09

NOTE: The following conditions apply for *Salmonella* and microbiological testing:

- (a) For prepackaged product received from a supplier and is not further processed, the contractor will furnish a CoA that the product represented is *Salmonella* negative and meets all microbiological requirements.
- (b) For bulk product received, the contractor is responsible for providing a CoA stating that the bulk product is *Salmonella* negative and meets all microbiological requirements. USDA *Salmonella* and additional microbiological testing is required for each end item lot and shall be the basis for lot acceptance with respect to *Salmonella* and other microbiological testing requirements.

E-6 QUALITY ASSURANCE PROVISIONS (PACKAGING AND PACKING MATERIALS)

A. Packaging.

PCR-C-082B
25 July 2019
SUPERSEDING
PCR-C-082A
29 May 2015

(1) Pouch material certification. The pouch material shall be tested for these characteristics. A Certificate of Conformance (CoC) may be accepted as evidence that the characteristics conform to the specified requirements. Compliance to 21 CFR substances in contact with hot water (less than or equal to 212°F) may be verified by CoC.

<u>Characteristic</u>	<u>Requirement paragraph</u>	<u>Test procedure</u>
Thickness of film for laminated material	D-1,A(1)a	ASTM D2103 <u>1/</u>
Aluminum foil thickness	D-1,A(1)a	ASTM B479 <u>2/</u>
Laminated material identification and construction	D-1,A(1)a	Laboratory evaluation
Color of laminated material	D-1,A(1)a	SAE AMS-STD-595 <u>3/</u>

1/ Standard Specification for Polyethylene Film and Sheeting

2/ Standard Specification for Annealed Aluminum and Aluminum-Alloy Foil for Flexible Barrier, Food Contact, and Other Applications

3/ Colors Used in Government Procurement

(2) Unfilled preformed pouch certification. A CoC may be accepted as evidence that unfilled pouches conform to the requirements specified in D-1,A(1)a and b. When deemed necessary by the USDA, testing of the unfilled preformed pouches for seal strength shall be as specified in E-6,B(1)a or b.

(3) Filled and sealed pouch examination. The filled and sealed pouches shall be examined for the defects listed in table II. The lot size shall be expressed in pouches. The sample unit shall be one pouch. The inspection level shall be I and the AQL, expressed in terms of defects per hundred units, shall be 0.65 for major defects and 2.5 for minor defects.

TABLE II. Filled and sealed pouch defects 1/

Category		Defect
<u>Major</u>	<u>Minor</u>	
101		Tear or hole or open seal.
102		Seal width less than 1/16 inch. <u>2/</u>
103		Presence of delamination. <u>3/</u>
104		Unclean pouch. <u>4/</u>
105		Pouch has foreign odor.
106		Any impression or design on the heat seal surfaces which conceals or impairs visual detection of seal defects. <u>5/</u>
107		Fill line missing or does not measure within $\pm 1/4$ inch of 5-3/4 inches from the inside edge of the bottom closure seal.
108		Not packaged as specified.
	201	Label missing or incorrect or illegible.
	202	Tear nick or notch missing or does not facilitate opening.
	203	Seal width less than 1/8 inch but greater than or equal to 1/16 inch. <u>2/</u>
	204	Presence of delamination. <u>3/</u>
	205	Pouch does not meet design or dimensions cited in Figure 1.
	206	Fill line on pouch not required thickness or length.
	207	Pouch closure seal more than 1/2 inch from the open end of the pouch.

1/ Any evidence of rodent or insect infestation shall be cause for rejection of the lot.

2/ The effective closure seal is defined as any uncontaminated, fusion bonded, continuous path, minimum 1/16 inch wide, from side seal to side seal that produces a hermetically sealed pouch.

3/ Delamination defect classification:

Major - Delamination of the outer ply in the pouch seal area that can be propagated to expose aluminum foil at the food product edge of the pouch after manual flexing of the delaminated area. To flex, the delaminated area shall be held between the thumb and forefinger of each hand with both thumbs and forefingers touching each other. The delaminated area shall then be rapidly flexed 10 times by rotating both hands in alternating clockwise-counterclockwise directions. Care shall be exercised when flexing delaminated areas near the tear notches to avoid tearing the pouch material. After flexing, the separated outer ply shall be grasped between thumb and forefinger and gently lifted toward the food product edge of the seal or if the separated area is too small to be held between thumb and forefinger, a number two stylus shall be inserted into the delaminated area and a gentle lifting force applied against the outer ply. If separation of the outer ply can be made to extend to the product edge of the seal with no discernible resistance to the gentle lifting, the delamination shall be classified as a major defect. Additionally, spot delamination of the outer ply in the body of the pouch that is able to be propagated beyond its initial borders is also a major defect. To determine if the laminated area is a defect, use the following procedure: Mark the outside edges of the delaminated area using a bold permanent marking pen. Open the pouch and remove the contents. Cut the pouch transversely not closer than 1/4 inch ($\pm 1/16$ inch) from the delaminated area. The pouch shall be flexed in the area in question using the procedure described above. Any propagation of the delaminated area, as evidenced by the delaminated area exceeding the limits of the outlined borders, shall be classified as a major defect.

Minor - Minor delamination of the outer ply in the pouch seal area is acceptable and shall not be classified as a minor defect unless it extends to within 1/16 inch of the food product edge of the seal. All other minor outer ply delamination in the pouch seal area or isolated spots of delamination in the body of the pouch that do not propagate when flexed as described above shall be classified as minor defects.

4/ Outer packaging shall be free from foreign matter which is unwholesome, has the potential to cause pouch damage (for example, glass, metal filings) or generally detracts from the clean appearance of the pouch. The following examples shall not be classified as defects for unclean:

a. Foreign matter which presents no health hazard or potential pouch damage and which can be readily removed by gently shaking the package or by gently brushing the pouch with a clean dry cloth.

b. Dried product which affects less than 1/8 of the total surface area of one pouch face (localized and aggregate).

5/ If doubt exists as to whether or not the sealing equipment leaves an impression or design on the closure seal surface that could conceal or impair visual detection of seal defects, samples shall be furnished to the contracting officer for a determination as to acceptability.

B. Methods of inspection.

(1) Seal testing. The pouch seals shall be tested for seal strength as required in a, b or c, as applicable.

a. Unfilled preformed pouch seal testing. The seals of the unfilled preformed pouch shall be tested for seal strength in accordance with ASTM F88/F88M, Standard Test Method for Seal Strength of Flexible Barrier Materials. The lot size shall be expressed in pouches. The sample unit shall be one unfilled pouch. The sample size shall be the number of pouches indicated by inspection level S-1. Three adjacent specimens shall be cut from each of the three sealed sides of each pouch in the sample. The average seal strength of any side shall be calculated by averaging the three specimens cut from that side. Any average seal strength of less than 6 pounds per inch of width or any test specimen with a seal strength of less than 5 pounds per inch of width shall be classified as a major defect and shall be cause for rejection of the lot.

b. Pouch closure seal testing. The closure seals of the pouches shall be tested for seal strength in accordance with ASTM F88/F88M. The lot size shall be expressed in pouches. The sample unit shall be one pouch. The sample size shall be the number of pouches indicated by inspection level S-1. For the closure seal on preformed pouches, three specimens shall be cut from the closure seal of each pouch in the sample. For the form-fill-seal pouches, three adjacent specimens shall be cut from each side and each end of each pouch in the sample. The average seal strength of any side, end or closure shall be calculated by averaging the three specimens cut from that side, end or closure. Any average seal strength of less than 6 pounds per inch of width or any test specimen with a seal strength of less than 5 pounds per inch of width shall be classified as a major defect and shall be cause for rejection of the lot.

c. Internal pressure test. The internal pressure resistance shall be determined by pressurizing the pouches while they are restrained between two rigid plates. The sample size shall be the number of pouches indicated by inspection level S-1. If a three-seal tester (one that pressurizes the pouch through an open end) is used, the closure seal shall be cut off for

testing the sides and end of the pouch. When testing the closure seal, the top and interlocking closure shall be cut off. The pouches shall be emptied prior to testing. If a four-seal tester (designed to pressurize filled pouches by use of a hypodermic needle through the pouch wall) is used, all four seals can be tested simultaneously. The distance between rigid restraining plates on the four-seal tester shall be equal to the thickness of the product + 1/16 inch. Pressure shall be applied at the approximate uniform rate of 1 pound per square inch gage (psig) per second until 14 psig pressure is reached. The 14 psig pressure shall be held constant for 30 seconds and then released. The pouches shall then be examined for separation or yield of the heat seals. Any rupture of the pouch or evidence of seal separation greater than 1/16 inch in the pouch manufacturer's seal shall be considered a test failure. Any seal separation that reduces the effective closure seal width to less than 1/16 inch (see table II, footnote 2/) shall be considered a test failure. Any test failure shall be classified as a major defect and shall be cause for rejection of the lot.

(2) Interlocking closure test. The interlocking closure of the pouch shall be tested. The lot size shall be expressed in pouches. The sample unit shall be one pouch. The sample size shall be the number of pouches indicated by inspection level S-2. Open a filled and sealed interlocking pouch and prepare beverage in accordance with instructions using 70°F (± 5°F) water. Close pouch. Invert pouch and suspend pouch for 15 seconds. Collect and measure any liquid that drips. Pouches that leak more than 15 ml shall be classified as a major defect and shall be cause for rejection of the lot.

C. Packing.

(1) Shipping container and marking examination. The filled and sealed shipping containers shall be examined for the defects listed in table III. The lot size shall be expressed in shipping containers. The sample unit shall be one shipping container fully packed. The inspection level shall be S-3 and the AQL, expressed in terms of defects per hundred units, shall be 4.0 for major defects and 10.0 for total defects.

TABLE III. Shipping container and marking defects

Category		Defect
<u>Major</u>	<u>Minor</u>	
101		Marking missing or incorrect or illegible.
102		Inadequate workmanship. 1/
	201	More than 40 pounds of product.

PCR-C-082B
25 July 2019
SUPERSEDING
PCR-C-082A
29 May 2015

1/ Inadequate workmanship is defined as, but not limited to, incomplete closure of container flaps, loose strapping, inadequate stapling, improper taping, or bulged or distorted container.

PCR-C-082B
25 July 2019
SUPERSEDING
PCR-C-082A
29 May 2015

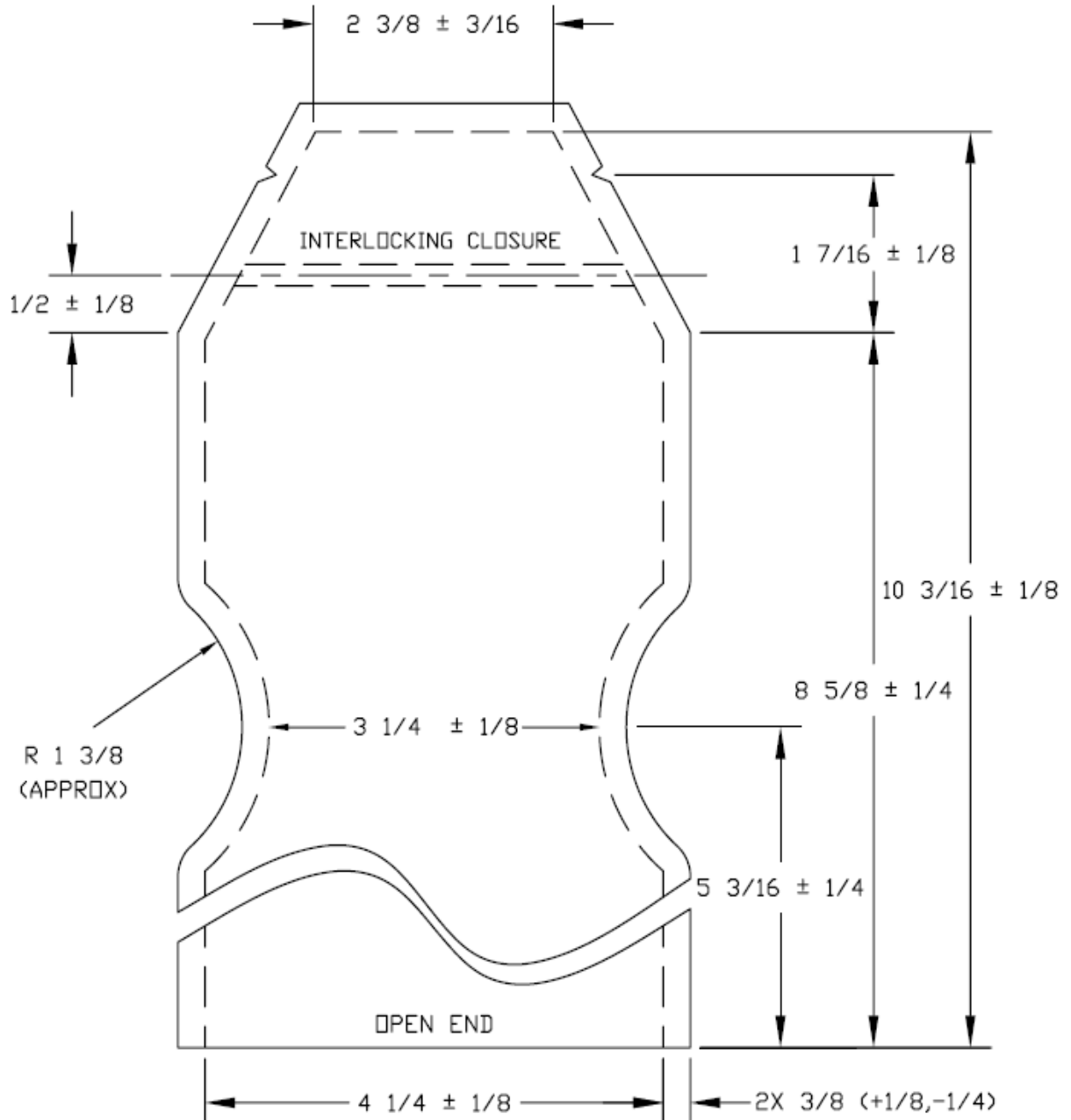

FIGURE 1. Design B Flat, Interlocking Closure Pouch
(Not actual size)

SECTION J REFERENCE DOCUMENTS

Unless otherwise specified, the applicable version of these documents is that which is active on the date of the solicitation or contract.

DLA Troop Support Form

Form 3556 Marking Instructions for Boxes, Sacks, and Unit Loads of
Perishable and Semiperishable Subsistence

GOVERNMENT PUBLICATIONS

FOOD AND DRUG ADMINISTRATION Bacteriological Analytical Manual (BAM)
<http://www.fda.gov/food/foodscienceresearch/laboratorymethods/ucm2006949.htm>

NON-GOVERNMENTAL STANDARDS

AMERICAN SOCIETY FOR QUALITY (ASQ) www.asq.org

ANSI/ASQ Z1.4 Sampling Procedures and Tables for Inspection by Attributes

AOAC INTERNATIONAL www.aoac.org

Official Methods of Analysis (OMA) of AOAC International

ASTM INTERNATIONAL www.astm.org

B479 Standard Specification for Annealed Aluminum and
Aluminum-Alloy Foil for Flexible Barrier, Food Contact,
and Other Applications

D1974/D1974M Standard Practice for Methods of Closing, Sealing, and
Reinforcing Fiberboard Boxes

D2103 Standard Specification for Polyethylene Film and Sheeting

D4727/D4727M Standard Specification for Corrugated and Solid Fiberboard
Sheet Stock (Container Grade) and Cut Shapes

PCR-C-082B
25 July 2019
SUPERSEDING
PCR-C-082A
29 May 2015

D5118/D5118M Standard Practice for Fabrication of Fiberboard Shipping
Boxes

F88/F88M Standard Test Method for Seal Strength of Flexible Barrier
Materials

SAE INTERNATIONAL www.sae.org

SAE AMS-STD-595 Colors Used in Government Procurement