

PCR-D-002B
13 August 2012
SUPERSEDING
PCR-D-002A
28 September 2007
W/CHANGE 01 14 Nov 2012

SECTION C

This document covers dairyshake powder, fortified with calcium and vitamin D packaged in a flexible pouch for use by the Department of Defense as a component of operational rations.

C-1 ITEM DESCRIPTION

PCR-D-002B DAIRYSHAKE POWDER, FORTIFIED WITH CALCIUM AND VITAMIN D, PACKAGED IN A FLEXIBLE POUCH, SHELF STABLE

Flavors.

Flavor I -	Vanilla
Flavor II -	Chocolate
Flavor III -	Strawberry
Flavor IV -	Strawberry banana

Types.

Type I -	Regular
Type II -	<i>Trans</i> fat free

Designs.

Design A -	Flat pouch (discontinued)
Design B -	Flat interlocking closure pouch

Packages.

Package A -	Meal, Cold Weather (MCW)
Package B -	Food Packet, Long Range Patrol (LRP)
Package C -	Meal, Ready to Eat™ (MRE™)
Package K -	Unitized Group Ration™ Express™ (UGR-E™)
Package J -	First Strike Ration® (FSR™)

Comment [jmb1]: ES13-001 (DSCP-SS-13-05188) change 01, 14 -Nov-12. p. 1, C-1, Packages, delete entire listing.

C-2 PERFORMANCE REQUIREMENTS

A. Product standard. A sample shall be subjected to first article (FA) or product demonstration model (PDM) inspection as applicable, in accordance with the tests and inspections of Section E of this Performance-based Contract Requirements (PCR) document. The approved sample shall serve as the product standard. Should the contractor at any time plan to or actually produce the product using different raw material or process methodologies from the approved product standard, which result in a product noncomparable to the product

PCR-D-002B
13 August 2012
SUPERSEDING
PCR-D-002A
28 September 2007
W/CHANGE 01 14 Nov 2012

standard, the contractor shall submit a replacement FA or PDM for approval. In any event, all product produced must meet all requirements of this document including product standard comparability.

B. Shelf life. The packaged product shall meet the minimum shelf life requirement of 36 months at 80°F.

C. Powdered product.

(1) Appearance. The dairyshake powder shall be a uniform blend of dry homogenous ingredients. The packaged food shall be free from foreign materials.

(2) Odor. The packaged food shall have an odor of the flavor specified. The packaged food shall be free from foreign odors.

(3) Texture. The packaged food shall be free flowing and shall be free from hard lumps that do not fall apart under light pressure between fingers.

(4) Instant nonfat dry milk. The dairyshake formula shall contain not less than 35 percent U. S. Extra Grade instant nonfat dry milk. Instant nonfat dry milk shall be U.S. Extra Grade, as defined in the U.S. Standards for Instant Nonfat Dry Milk. The U.S. Extra Grade instant nonfat dry milk shall be fortified with vitamin A and vitamin D. The U.S. Extra Grade instant nonfat dry milk shall be spray dried not more than six months prior to the time the finished dairyshake powder is filled into the pouch and the pouch sealed. The U.S. Extra Grade instant nonfat dry milk shall be *Salmonella* free.

(5) Dry sweet dairy whey. When dry sweet dairy whey is used, the dry sweet dairy whey shall meet the requirements for U.S. Standards for Dry Whey. When dry sweet dairy whey is used, the dry sweet dairy whey shall be spray dried not more than six months prior to the time the finished dairyshake powder is filled into the pouch and the pouch sealed. When dry sweet dairy whey is used, the dry sweet dairy whey ingredient shall be *Salmonella* free.

D. Hydrated product.

(1) Appearance. The hydrated product shall have a color as specified below.

a. Flavor I. The vanilla dairyshake shall be a pale to medium cream color.

b. Flavor II. The chocolate dairyshake shall be a light to medium brown color.

PCR-D-002B
13 August 2012
SUPERSEDING
PCR-D-002A
28 September 2007
W/CHANGE 01 14 Nov 2012

c. Flavor III. The strawberry dairyshake shall be a light to medium pink color.

d. Flavor IV. The strawberry banana dairyshake shall be a light to medium pink color.

(2) Odor and flavor. The hydrated product shall be free from foreign odors and flavors and shall have an odor and flavor as specified below.

a. Flavor I. The vanilla dairyshake shall have a sweet vanilla odor and a moderately intense sweet vanilla flavor.

b. Flavor II. The chocolate dairyshake shall have a sweet chocolate odor and a moderately intense sweet chocolate flavor.

c. Flavor III. The strawberry dairyshake shall have a sweet strawberry odor and a moderately intense sweet strawberry flavor.

d. Flavor IV. The strawberry banana dairyshake shall have a sweet strawberry banana odor and moderately intense sweet strawberry banana flavor.

(3) Texture. The prepared product shall be smooth, creamy, and moderately thick with no discernible lumps, chalkiness or sedimentation.

E. Net weight.

(1) ~~Packages A, B, and K. The average net weight shall be not less than 3.5 ounces (100 grams). The net weight of an individual pouch shall be not less than 3.4 ounces (96 grams).~~

(2) ~~Packages C and J. The average net weight shall be not less than 2.5 ounces (70 grams). The net weight of an individual pouch shall be not less than 2.4 ounces (68 grams).~~

Comment [SL2]: ES13-001 (DSCP-SS-13-05188) change 01, 14 -Nov- 12 p. 3,C-2, E. Packages, delete entire subparagraph (1); subparagraph (2), delete "(2) Packages C and J." heading and keep content of subparagraph.

F. Palatability and overall appearance. The finished product shall be equal to or better than the approved product standard in palatability and overall appearance.

G. Analytical requirements.

(1) Protein. The protein content shall be not less than 15.0 percent.

PCR-D-002B
13 August 2012
SUPERSEDING
PCR-D-002A
28 September 2007
W/CHANGE 01 14 Nov 2012

(2) Fat. For flavors I-IV type I, the fat content shall be not greater than 21.0 percent. For flavors I-IV type II, the *trans* fat content shall be not greater than 0 grams per serving.

(3) Salt. The salt content shall be not greater than 1.0 percent.

(4) Moisture. The moisture content shall be not greater than 3.5 percent.

(5) Calcium. The calcium content shall be not less than 400 mg and not greater than 650 mg per 100 grams of product.

(6) Vitamin D. The Vitamin D content shall be not less than 100 IU and not greater than 200 IU per 100 grams of product.

H. Microbiological requirements. The aerobic plate count shall be not greater than 50,000 per gram in four of five samples and not greater than 75,000 per gram in any individual sample. The *Eschericia coli* shall have less than 10 colony forming units (CFU) per gram or less than 3 most probable number (MPN) per gram where findings indicate zero colonies CFU per plate or zero tubes producing gas for MPN. The *Salmonella* test shall be negative for each of five pouches tested per production lot.

C-3 MISCELLANEOUS INFORMATION.

THE FOLLOWING IS INFORMATION ONLY TO PROVIDE THE BENEFIT OF PAST GOVERNMENT EXPERIENCE. THIS IS NOT A MANDATORY CONTRACT REQUIREMENT.

A. Product preparation. Percentages for product preparation may be as follows:

(1) Flavor I, type I - vanilla, regular. 1/

<u>Ingredients</u>	<u>Percent by weight</u>
Milk, nonfat, dry, instant	45.3998
Non-dairy creaming agent	27.2000
Sugar, white, powdered	18.2000
Dry sweet dairy whey	4.5000
Starch, instant	2.7000
Calcium caseinate	1.9000
Titanium dioxide	0.0379
Flavoring, vanilla, artificial	0.0300

PCR-D-002B
13 August 2012
SUPERSEDING
PCR-D-002A
28 September 2007
W/CHANGE 01 14 Nov 2012

Flavoring, French vanilla, natural and artificial	0.0300
Color, Yellow No. 5	0.0018
Color, Red No. 40	0.0005

(2) Flavor II, type I – chocolate, regular. 1/

<u>Ingredients</u>	<u>Percent by weight</u>
Milk, nonfat, dry, instant	39.000
Non-dairy creaming agent	23.440
Sugar, white, powdered	23.400
Cocoa	6.200
Dry sweet dairy whey	3.900
Starch, instant	2.300
Calcium caseinate	1.600
Flavoring, chocolate, artificial	0.120
Flavoring, vanilla, artificial	0.020
Flavoring, French vanilla, natural and artificial	0.020

(3) Flavor III, type I – strawberry, regular. 1/

<u>Ingredients</u>	<u>Percent by weight</u>
Milk, nonfat, dry, instant	45.300
Non-dairy creaming agent	27.301
Sugar, white, powdered	18.100
Dry sweet dairy whey	4.500
Starch, instant	2.700
Calcium caseinate	1.800
Flavoring, strawberry, artificial	0.230
Flavoring, vanilla, artificial	0.030
Flavoring, French vanilla, natural and artificial	0.030
Color, Red No. 40	0.009

1/ Vitamin D shall be added to products so that the requirement of 100 IU of Vitamin D shall be met.

THE FOLLOWING IS FOR INFORMATION ONLY. THIS IS NOT A MANDATORY CONTRACT REQUIREMENT.

B. Ingredients.

PCR-D-002B
13 August 2012
SUPERSEDING
PCR-D-002A
28 September 2007
W/CHANGE 01 14 Nov 2012

(1) Flavor IV, type I – strawberry banana, regular. Nonfat dry milk, non-dairy creamer {partially hydrogenated soybean oil, maltodextrin, sodium caseinate (a milk derivative), dipotassium phosphate, polysorbate 60, and monoglycerides}, sugar, whey, modified food starch, calcium caseinate, cellulose gum, xanthan gum, carrageenan, acacia gum, natural and artificial flavors, red no. 40, and vitamin D.

(2) Flavor I, type II – vanilla, trans fat free. Nonfat milk fortified with vitamin A palmitate and vitamin D3, sugar, non-dairy creamer, maltodextrin, whey, modified food starch, calcium caseinate, less than 2 percent of the following (natural and artificial flavors, xanthan gum, natural vegetable color).

(3) Flavor II, type II – chocolate, trans fat free. Nonfat milk fortified with vitamin A palmitate and vitamin D3, sugar, non-dairy creamer, maltodextrin, whey, modified food starch, cocoa (processed with alkali), calcium caseinate, less than 2 percent of the following (natural and artificial flavors, xanthan gum).

(4) Flavor III, type II – strawberry, trans fat free. Nonfat milk fortified with vitamin A palmitate and vitamin D3, sugar, non-dairy creamer, maltodextrin, whey, modified food starch, calcium caseinate, less than 2 percent of the following (natural flavors, citric acid, xanthan gum, natural vegetable color).

(5) Flavor IV, type II – strawberry banana, trans fat free. Nonfat milk fortified with vitamin A palmitate and vitamin D3, sugar, non-dairy creamer, maltodextrin, whey, modified food starch, calcium caseinate, less than 2 percent of the following (natural flavors, citric acid, xanthan gum, natural vegetable color).

NOTE: Coconut oil has been successfully tested at Natick Soldier Research, Development and Engineering Center as a substitute for partially hydrogenated oils in this product. Type II *trans* fat free products supplied by Challenge Dairy Products, Inc., Dublin, CA 94568.

SECTION D

PCR-D-002B
13 August 2012
SUPERSEDING
PCR-D-002A
28 September 2007
W/CHANGE 01 14 Nov 2012

D-1 PACKAGING

A. Packaging. ~~For Packages A, B, and K, 3.5 ounces (100 grams) of powdered product shall be filled into a preformed barrier pouch. For Packages C and J, 2.5 ounces (70 grams)~~ **Seventy grams** of powdered product shall be filled into a preformed barrier pouch. The pouch is to be used as a package and a hydrating pouch for the dairysshake powder.

Comment [jmb3]: ES13-001 (DSCP-SS-13-05188) change 01, 14- Nov-12. p. 7, Section D-1, A, delete first and second sentences. Add new second sentence "Seventy grams of powdered product shall be filled into a preformed barrier pouch."

(1) Design B, Flat interlocking closure pouch.

a. Pouch material. The pouch shall be fabricated from 0.002 inch thick ionomer or polyethylene film laminated or extrusion coated to 0.00035 inch thick aluminum foil which is then bonded to 0.0005 inch thick polyester. The three plies may be laminated with nylon on the exterior of the pouch. Tolerances for thickness of plastic films shall be plus or minus 20 percent and tolerance for foil layer shall be plus or minus 10 percent. The material shall show no evidence of delamination, degradation, or foreign odor when heat sealed or fabricated into pouches. The material shall be suitably formulated for food packaging and shall not impart an odor or flavor to the product. The complete exterior surface of the pouch shall be uniformly colored in the range of 20219, 30219, 30227, 30279, 30313, 30324, or 30450 of FED-STD-595, Colors Used in Government Procurement.

b. Pouch construction. The pouch shall be a flat design preformed or vertical form-fill-seal pouch with an interlocking closure. The design and dimensions shall be as indicated in figure 1. The pouch shall be made by heat sealing the sides and top of the pouch with 3/8 (+1/8, -1/4) inch wide seals. The pouch shall exhibit no rupture or seal separation greater than 1/16 inch when tested for internal pressure resistance. The interlocking closure of the pouch shall not leak more than 15 ml when tested in accordance with E-6,B(2). A tear nick or notch shall be provided on one or two opposite edges of the pouch above the interlocking closure to facilitate opening of the filled and sealed pouch. A 1/8 inch wide lip may be incorporated at the open end of the pouch.

c. Pouch filling and sealing. Product shall be inserted into the pouch and the filled pouch shall be sealed with a 1/8 to 1 inch wide heat seal. The closure seal shall be applied not more than 1/2 inch from the open end of the pouch. The closure seals shall be free of foldover wrinkles or entrapped matter that reduces the effective closure seal width to less than 1/16 inch. Seals shall be free of impression or design on the seal surface that would conceal or impair visual detection of seal defects. The average seal strength shall be not less than 6 pounds per inch of width and no individual specimen shall have a seal strength of less than 5 pounds per inch of width. Alternatively, the filled and sealed pouch shall exhibit no

PCR-D-002B
13 August 2012
SUPERSEDING
PCR-D-002A
28 September 2007
W/CHANGE 01 14 Nov 2012

rupture or seal separation greater than 1/16 inch or seal separation that reduces the effective closure seal width to less than 1/16 inch when tested for internal pressure resistance.

D-2 LABELING

A. Pouches. Each pouch shall be correctly and legibly labeled. Printing ink shall be permanent black ink or other dark contrasting color which is free of carcinogenic elements. The label shall contain the following information:

- (1) Name and flavor of product (letters not less than 1/8 inch high)
- (2) Ingredients
- (3) Date 1/
- (4) Net weight
- (5) Name and address of packer
- (6) "Nutrition Facts" label in accordance with the Nutrition Labeling and Education Act (NLEA) and all applicable FDA regulations
- (7) Directions:

Allow water just chemically purified to stand 30 minutes before adding to powder. Tear pouch at notch. Open zipper, add 6 ounces of water (about 1/4 canteen cup) to fill line. Close zipper, shake to mix (about 60 seconds). Consume promptly (within 1 hour). *Single use only*.

Fill line:

~~Packages A, B, and K. A fill line (not less than 1/32 inch thick, not less than 2 inches long and centered) shall be placed on the pouch/label for 6 ounce (170 grams) fill at 5 1/4 ± 1/4 inches from the inside edge of the bottom closure seal.~~
~~Packages C and J. A~~ fill line (not less than 1/32 inch thick, not less than 2 inches long and centered) shall be placed on the pouch/label for 6-ounce (170 grams) fill at 4-1/2 ± 1/4 inches from the inside edge of the bottom closure seal.

Comment [jmb4]: ES113-001(DSCP-SS-13-05188) change 01, 14- Nov -12. p 8, D-2, A, Fill line: delete first sentence and "Packages C and J" from beginning of second sentence. Add "A" at beginning of second sentence.

1/ Each pouch shall have the date of pack noted by using a four digit code beginning with the final digit of the current year followed by the three digit Julian day code. For example, 14 February 2011 would be coded as 1045. The Julian day code shall represent the day the product was packaged into the pouch. Sub-lotting (when used) shall be represented by an alpha character immediately following the four digit Julian code. Following the four digit Julian code and the alpha character (when used), the other required code information shall be printed in the sequence as listed above.

PCR-D-002B
13 August 2012
SUPERSEDING
PCR-D-002A
28 September 2007
W/CHANGE 01 14 Nov 2012

D-3 PACKING

A. Packing. Not more than 40 pounds of product shall be packed in a fiberboard shipping box constructed in accordance with style RSC-L of ASTM D5118/D5118M, Standard Practice for Fabrication of Fiberboard Shipping Boxes. The fiberboard shall conform to type CF, class D, variety SW, burst grade 200 or ECT grade 32 of ASTM D4727/D4727M, Standard Specification for Corrugated and Solid Fiberboard Sheet Stock (Container Grade) and Cut Shapes. Each box shall be closed in accordance with ASTM D1974/1974M, Standard Practice for Methods of Closing, Sealing, and Reinforcing Fiberboard Boxes.

D-5 MARKING

A. Shipping containers. Shipping containers shall be marked in accordance with DLA Troop Support Form 3556, Marking Instructions for Boxes, Sacks, and Unit Loads of Perishable and Semiperishable Subsistence.

SECTION E INSPECTION AND ACCEPTANCE

The following quality assurance criteria, utilizing ANSI/ASQ Z1.4, Sampling Procedures and Tables for Inspection by Attributes, are required. Unless otherwise specified, single sampling plans indicated in ANSI/ASQ Z1.4 will be utilized. When required, the manufacturer shall provide the Certificate(s) of Conformance to the appropriate inspection activity. Certificate(s) of Conformance not provided shall be cause for rejection of the lot.

A. Definitions.

(1) Critical defect. A critical defect is a defect that judgment and experience indicate would result in hazardous or unsafe conditions for individuals using, maintaining, or depending on the item; or a defect that judgment and experience indicate is likely to prevent the performance of the major end item, i.e., the consumption of the ration.

(2) Major defect. A major defect is a defect, other than critical, that is likely to result in failure, or to reduce materially the usability of the unit of product for its intended purpose.

(3) Minor defect. A minor defect is a defect that is not likely to reduce materially the usability of the unit of product for its intended purpose, or is a departure from established standards having little bearing on the effective use or operation of the unit.

PCR-D-002B
13 August 2012
SUPERSEDING
PCR-D-002A
28 September 2007
W/CHANGE 01 14 Nov 2012

B. Classification of inspections. The inspection requirements specified herein are classified as follows:

(1) Product standard inspection. The first article or product demonstration model shall be inspected in accordance with the provisions of this document and evaluated for appearance, odor, flavor, and texture. Any failure to conform to the performance requirements or any appearance or palatability failure shall be cause for rejection of the lot. The approved first article or product demonstration model shall be used as the product standard for periodic review evaluations. All food components that are inspected by the USDA shall be subject to periodic review sampling and evaluation. The USDA shall select sample units during production of contracts and submit them to the following address for evaluation:

US Army Research, Development and Engineering Command
Natick Soldier Research, Development and Engineering Center
RDNS-CFF
15 Kansas Street
Natick, MA 01760-5056

One lot shall be randomly selected during each calendar month of production or as otherwise specified in the contract. Six (6) sample units shall be randomly selected from that one production lot. The six (6) sample units shall be shipped to Natick within five (5) working days from the end of the production month from which they are randomly selected and upon completion of all USDA inspection requirements. The sample units will be evaluated for overall quality against the current first article or product demonstration model.

(2) Conformance inspection. Conformance inspection shall include the examinations and the methods of inspection cited in this section.

E-5 QUALITY ASSURANCE PROVISIONS (PRODUCT)

A. Product examination. The finished product shall be examined for compliance with the performance requirements specified in Section C of this Performance-based Contract Requirements document utilizing the double sampling plans indicated in ANSI/ASQ Z1.4. The lot size shall be expressed in pouches. The sample unit shall be one filled and sealed pouch. The inspection level shall be S-3 and the acceptable quality level (AQL), expressed in terms of defects per hundred units, shall be 1.5 major defects and 4.0 for minor defects. Defects and defect classifications are listed in table I.

PCR-D-002B
13 August 2012
SUPERSEDING
PCR-D-002A
28 September 2007
W/CHANGE 01 14 Nov 2012

TABLE I. Product defects 1/ 2/ 3/ 4/ 5/ 6/ 7/

Category	Defect
<u>Major</u>	<u>Minor</u>
<u>Powdered product</u>	
<u>Appearance</u>	
101	Not flavor or not type as specified.
102	Not a uniform blend of dry homogenous ingredients.
<u>Odor</u>	
103	Not odor of flavor specified.
<u>Texture</u>	
201	Not free flowing.
202	Presence of hard lumps. 8/
<u>Net weight</u>	
203	Net weight of an individual pouch less than 3.4 ounces (95 grams) or less than 2.4 ounces (67 grams), as applicable. 9/
<u>Hydrated product 10/</u>	
<u>Appearance</u>	
204	Flavor I vanilla dairyshake not a pale to medium cream color.
205	Flavor II chocolate dairyshake not a light to medium brown color.
206	Flavor III strawberry dairyshake not a light to medium pink color.
207	Flavor IV strawberry banana dairyshake not a light to medium pink color.

Comment [SL5]: ES13-001 (DSCP-SS-13-05188) change 01, 14- Nov-12. p 11, E-5, A, Table I, Product defects, minor defect 203, delete "less than 3.4 ounces (95 grams) or" and delete "as applicable".

PCR-D-002B
13 August 2012
SUPERSEDING
PCR-D-002A
28 September 2007
W/CHANGE 01 14 Nov 2012

TABLE I. Product defects 1/ 2/ 3/ 4/ 5/ 6/ 7/ - Continued

Category		Defect
<u>Major</u>	<u>Minor</u>	
		<u>Odor and flavor</u>
104		Flavor I vanilla dairyshake not a sweet vanilla odor or not a moderately intense sweet vanilla flavor.
105		Flavor II chocolate dairyshake not a sweet chocolate odor or not a moderately intense sweet chocolate flavor.
106		Flavor III strawberry dairyshake not a sweet strawberry odor or not a moderately intense sweet strawberry flavor.
107		Flavor IV strawberry banana dairyshake not a sweet strawberry banana odor or not a moderately intense sweet strawberry banana flavor.
		<u>Texture</u>
108		Not smooth or not creamy or not moderately thick.
109		Has discernible lumps or chalkiness or sedimentation.

1/ Presence of any foreign materials such as, but not limited to dirt, insect parts, hair, glass, wood, or metal, or any foreign odors or flavors such as, but not limited to burnt, scorched, rancid, sour, stale, oxidized milk powder, musty or moldy shall be cause for rejection of the lot. Foreign flavors not applicable to powdered product.

2/ Finished product not equal to or better than the approved product standard in palatability and overall appearance shall be cause for rejection of the lot. Palatability not applicable to powdered product.

3/ The percentage of U.S. Extra Grade instant nonfat dry milk in the dairyshake formula shall be verified by the producer's formulation. Product not conforming to the percentage of U.S. Extra Grade instant nonfat dry milk requirement shall be cause for rejection of the lot.

PCR-D-002B
13 August 2012
SUPERSEDING
PCR-D-002A
28 September 2007
W/CHANGE 01 14 Nov 2012

- 4/ The age requirement for U.S. Extra Grade instant nonfat dry milk shall be verified by a producer's Certificate of Conformance (CoC). When dry sweet dairy whey is used, the age requirement for dry sweet dairy whey shall be verified by a producer's CoC.
- 5/ The producer shall provide a USDA Grading Certificate indicating that the instant nonfat dry milk used in the formulation met all the requirements for U.S. Extra Grade. USDA Grading Certificate not provided shall be cause for rejection of the lot.
- 6/ The *Salmonella* free requirement for U.S. Extra Grade instant nonfat dry milk shall be verified by a Certificate of Analysis (CoA). When dry sweet dairy whey is used, *Salmonella* free requirement for the dry sweet dairy whey ingredient shall be verified by a CoA. CoA not provided shall be cause for rejection of the lot.
- 7/ *Trans* fat content shall be verified by the NLEA "Nutrition Facts" label. Product not conforming to the *trans* fat content as specified in section C of this document shall be cause for rejection of the lot.
- 8/ Lumps that do not fall apart under light pressure shall be scored as a defect.
- 9/ ~~For packages A, B, and K, sample average net weight less than 3.5 ounces (100 grams) shall be cause for rejection of the lot. For packages C and J, s~~ Sample average net weight less than 2.5 ounces (70 grams) shall be cause for rejection of the lot.

Comment [jmb6]: ES13-001 (DSCP-SS-13-05188) change 01, 14- Nov-12. p 13, E-5, A, Table I, Product defects, footnote 9, delete first sentence and beginning of second sentence "For packages C and J,".

10/ Prior to conducting the hydrated product exam, reconstitute the dairyshake powder per label instructions.

B. Methods of inspection.

(1) Shelf life. The contractor shall provide a Certificate of Conformance that the product has a 36 month shelf life when stored at 80°F. Government verification may include storage for 6 months at 100°F or 36 months at 80°F. Upon completion of either storage period, the product will be subjected to a sensory evaluation panel for appearance and palatability and must receive an overall score of 5 or higher based on a 9 point quality scale to be considered acceptable.

(2) Net weight. The net weight of the filled and sealed pouch shall be determined by weighing each sample unit on a suitable scale tared with a representative empty pouch. Results shall be reported to the nearest 0.1 ounce or to the nearest 1 gram.

PCR-D-002B
13 August 2012
SUPERSEDING
PCR-D-002A
28 September 2007
W/CHANGE 01 14 Nov 2012

(3) Analytical. The sample to be analyzed shall be a composite of eight filled and sealed pouches which have been selected at random from the lot. The composite sample shall be prepared and analyzed in accordance with the following methods of the Official Methods of Analysis (OMA) of AOAC International or American Public Health Association (APHA) Standard Methods for the Examination of Dairy Products (17th Edition):

<u>Test</u>	<u>Method Number</u>
Protein	992.15, 984.13
Fat	932.06, 991.36, 2003.05, 2008.06, 15.SMEDP 15.122
Salt	935.47, 2007.04
Moisture	925.45A, the product shall be dried for 16 hours at 70°C; 2008.06, SMEDP 15.115
Calcium	984.27, 985.35, 2011.14 <u>1/</u>
Vitamin D	2002.05, 2011.12, 2011.13 <u>1/</u>

Test results shall be reported to the nearest 0.1 percent for protein, fat, salt and moisture. Verification will be conducted through actual testing by a Government laboratory. Any result not conforming to the analytical requirement shall be cause for rejection of the lot.

1/ Tests will be conducted for calcium and Vitamin D on the first production lot of a contract cycle. USDA will perform the verification testing and obtain a copy of the formulation used in the production of that lot. A CoC for nutrient content for calcium and Vitamin D will be provided on all future lots produced using the same formulation. If the formula is changed or a new contract starts, then another set of tests shall be conducted by USDA, for calcium and Vitamin D, and USDA will obtain a copy of the formulation.

(4) Microbiological testing. Five filled and sealed pouches shall be selected at random from the lot regardless of lot size. The pouched product shall be individually tested for microbiological levels in accordance with the OMA of the AOAC, for aerobic plate count method 966.23 or 990.12 and for *E.coli*, method 966.24, 992.30 or the methods on page 4.03 Section C and page 4.05, Section F, Chapter 4, 8th edition, FDA Bacteriological Analytical Manual (BAM). The diluent shall be added to each sample and allowed to stand for 15 minutes before blending the sample. *Salmonella* testing shall be in accordance with the OMA of the AOAC, methods 967.26, 967.28, 986.35, 991.13, 996.08, 2003.09 or 2004.03. Any result not conforming to the microbiological requirements shall be cause for rejection of the lot.

NOTE: The following conditions apply for *Salmonella* and microbiological testing:

PCR-D-002B
13 August 2012
SUPERSEDING
PCR-D-002A
28 September 2007
W/CHANGE 01 14 Nov 2012

a. For prepackaged product received from a supplier and is not further processed, the contractor will furnish a CoA that the product represented is *Salmonella* negative and meets all microbiological requirements.

b. For bulk product received, the contractor is responsible for providing a CoA stating that the bulk product is *Salmonella* negative and meets all microbiological requirements. USDA *Salmonella* and additional microbiological testing is required for each end item lot and shall be the basis for lot acceptance with respect to *Salmonella* and other microbiological testing requirements.

E-6 QUALITY ASSURANCE PROVISIONS (PACKAGING AND PACKING MATERIALS)

A. Packaging.

(1) Pouch material certification. The pouch material shall be tested for these characteristics. A Certificate of Conformance (CoC) may be accepted as evidence that the characteristics conform to the specified requirements.

<u>Characteristic</u>	<u>Requirement paragraph</u>	<u>Test procedure</u>
Thickness of film for laminated material	D-1A(1)a	ASTM D2103 <u>1/</u>
Aluminum foil thickness	D-1A(1)a	ASTM B479 <u>2/</u>
Laminated material identification and construction	D-1A(1)a	Laboratory evaluation
Color of laminated material	D-1A(1)a	FED-STD-595 <u>3/</u>

1/ Standard Specification for Polyethylene Film and Sheeting

2/ Standard Specification for Annealed Aluminum and Aluminum-Alloy Foil for Flexible Barrier, Food Contact, and Other Applications

3/ Colors Used in Government Procurement

(2) Unfilled preformed pouch certification. A CoC may be accepted as evidence that unfilled pouches conform to the requirements specified in D-1A(1)a and b. When deemed

PCR-D-002B
13 August 2012
SUPERSEDING
PCR-D-002A
28 September 2007
W/CHANGE 01 14 Nov 2012

necessary by the USDA, testing of the unfilled preformed pouches for seal strength shall be as specified in E-6,B(1)a or b.

(3) Filled and sealed pouch examination. The filled and sealed pouches shall be examined for the defects listed in table II. The lot size shall be expressed in pouches. The sample unit shall be one pouch. The inspection level shall be I and the AQL, expressed in terms of defects per hundred units, shall be 0.65 for major defects and 2.5 for minor defects.

TABLE II. Filled and sealed pouch defects 1/

Category	Defect
<u>Major</u>	<u>Minor</u>
101	Tear or hole or open seal.
102	Seal width less than 1/16 inch. <u>2/</u>
103	Presence of delamination. <u>3/</u>
104	Unclean pouch. <u>4/</u>
105	Pouch has foreign odor.
106	Any impression or design on the heat seal surfaces which conceals or impairs visual detection of seal defects. <u>5/</u>
107	Fill line missing or does not measure within $\pm 1/4$ inch of 5-1/4 inches or does not measure within $\pm 1/4$ inch of 4-1/2 inches , as applicable, from the inside edge of the bottom closure seal.
108	Not packaged as specified.
201	Label missing or incorrect or illegible.
202	Tear nick or notch missing or does not facilitate opening.
203	Seal width less than 1/8 inch but greater than or equal to 1/16 inch. <u>2/</u>
204	Presence of delamination. <u>3/</u>
205	Pouch does not meet design or dimensions cited in Figure 1.

PCR-D-002B
13 August 2012
SUPERSEDING
PCR-D-002A
28 September 2007
W/CHANGE 01 14 Nov 2012

TABLE II. Filled and sealed pouch defects 1/ - Continued

Category	Defect
<u>Major</u>	<u>Minor</u>
	206
	207

1/ Any evidence of rodent or insect infestation shall be cause for rejection of the lot.

2/ The effective closure seal is defined as any uncontaminated, fusion bonded, continuous path, minimum 1/16 inch wide, from side seal to side seal that produces a hermetically sealed pouch.

3/ Delamination defect classification:

Major - Delamination of the outer ply in the pouch seal area that can be propagated to expose aluminum foil at the food product edge of the pouch after manual flexing of the delaminated area. To flex, the delaminated area shall be held between the thumb and forefinger of each hand with both thumbs and forefingers touching each other. The delaminated area shall then be rapidly flexed 10 times by rotating both hands in alternating clockwise- counterclockwise directions. Care shall be exercised when flexing delaminated areas near the tear notches to avoid tearing the pouch material. After flexing, the separated outer ply shall be grasped between thumb and forefinger and gently lifted toward the food product edge of the seal or if the separated area is too small to be held between thumb and forefinger, a number two stylus shall be inserted into the delaminated area and a gentle lifting force applied against the outer ply. If separation of the outer ply can be made to extend to the product edge of the seal with no discernible resistance to the gentle lifting, the delamination shall be classified as a major defect. Additionally, spot delamination of the outer ply in the body of the pouch that is able to be propagated beyond its initial borders is also a major defect. To determine if the laminated area is a defect, use the following procedure: Mark the outside edges of the delaminated area using a bold permanent marking pen. Open the pouch and remove the contents. Cut the pouch transversely not closer than 1/4 inch ($\pm 1/16$ inch) from the delaminated area. The pouch shall be flexed in the area in question using the procedure described above. Any propagation of the delaminated area, as evidenced by the delaminated area exceeding the limits of the outlined borders, shall be classified as a major defect.

PCR-D-002B
13 August 2012
SUPERSEDING
PCR-D-002A
28 September 2007
W/CHANGE 01 14 Nov 2012

Minor - Minor delamination of the outer ply in the pouch seal area is acceptable and shall not be classified as a minor defect unless it extends to within 1/16 inch of the food product edge of the seal. All other minor outer ply delamination in the pouch seal area or isolated spots of delamination in the body of the pouch that do not propagate when flexed as described above shall be classified as minor defects.

4/ Outer packaging shall be free from foreign matter which is unwholesome, has the potential to cause pouch damage (for example, glass, metal filings) or generally detracts from the clean appearance of the pouch. The following examples shall not be classified as defects for unclean:

a. Foreign matter which presents no health hazard or potential pouch damage and which can be readily removed by gently shaking the package or by gently brushing the pouch with a clean dry cloth.

b. Dried product which affects less than 1/8 of the total surface area of one pouch face (localized and aggregate).

5/ If doubt exists as to whether or not the sealing equipment leaves an impression or design on the closure seal surface that could conceal or impair visual detection of seal defects, samples shall be furnished to the contracting officer for a determination as to acceptability.

B. Methods of inspection.

(1) Seal testing. The pouch seals shall be tested for seal strength as required in a, b or c, as applicable.

a. Unfilled preformed pouch seal testing. The seals of the unfilled preformed pouch shall be tested for seal strength in accordance with ASTM F88, Standard Test Method for Seal Strength of Flexible Barrier Materials. The lot size shall be expressed in pouches. The sample unit shall be one pouch. The sample size shall be the number of pouches indicated by inspection level S-1. Three adjacent specimens shall be cut from each of the three sealed sides of each pouch in the sample. The average seal strength of any side shall be calculated by averaging the three specimens cut from that side. Any average seal strength of less than 6 pounds per inch of width or any test specimen with a seal strength of less than 5 pounds per inch of width shall be classified as a major defect and shall be cause for rejection of the lot.

PCR-D-002B
13 August 2012
SUPERSEDING
PCR-D-002A
28 September 2007
W/CHANGE 01 14 Nov 2012

b. Pouch closure seal testing. The closure seals of the pouches shall be tested for seal strength in accordance with ASTM F88. The lot size shall be expressed in pouches. The sample unit shall be one pouch. The sample size shall be the number of pouches indicated by inspection level S-1. For the closure seal on preformed pouches, three specimens shall be cut from the closure seal of each pouch in the sample. For vertical form-fill-seal pouches, three adjacent specimens shall be cut from each side and each end of each pouch in the sample. The average seal strength of any side, end or closure shall be calculated by averaging the three adjacent specimens cut from that side, end or closure. Any average seal strength of less than 6 pounds per inch of width or any test specimen with a seal strength of less than 5 pounds per inch of width shall be classified as a major defect and shall be cause for rejection of the lot.

c. Internal pressure test. The internal pressure resistance shall be determined by pressurizing the pouches while they are restrained between two rigid plates. The lot size shall be expressed in pouches. The sample unit shall be one pouch. The sample size shall be the number of pouches indicated by inspection level S-1. If a three seal tester (one that pressurizes the pouch through an open end) is used, the closure seal shall be cut off for testing the sides and end of the pouch. For design B pouch, when testing the closure seal, the top and interlocking closure shall be cut off. The pouches shall be emptied prior to testing. If a four-seal tester (designed to pressurize filled pouches by use of a hypodermic needle through the pouch wall) is used, all four seals can be tested simultaneously. The distance between rigid restraining plates on the four-seal tester shall be equal to the thickness of the product + 1/16 inch. Pressure shall be applied at the approximate uniform rate of 1 pound per square inch gage (psig) per second until 14 psig pressure is reached. The 14 psig pressure shall be held constant for 30 seconds and then released. The pouches shall then be examined for separation or yield of the heat seals. Any rupture of the pouch or evidence of seal separation greater than 1/16 inch in the pouch manufacturer's seal shall be considered a test failure. Any seal separation that reduces the effective closure seal width to less than 1/16 inch (see table II, footnote 2/) shall be considered a test failure. Any test failure shall be classified as a major defect and shall be cause for rejection of the lot.

(2) Interlocking closure test. The interlocking closure of the pouch shall be tested. The lot size shall be expressed in pouches. The sample unit shall be one pouch. The sample size shall be the number of pouches indicated by inspection level S-2. Open a filled and sealed interlocking pouch and prepare beverage in accordance with instructions using 70°F ($\pm 5^\circ\text{F}$) water. Close pouch. Invert pouch and suspend pouch for 15 seconds. Collect and measure any liquid that drips. Pouches that leak more than 15 ml shall be classified as a major defect and shall be cause for rejection of the lot.

PCR-D-002B
13 August 2012
SUPERSEDING
PCR-D-002A
28 September 2007
W/CHANGE 01 14 Nov 2012

C. Packing.

(1) Shipping container and marking examination. The filled and sealed shipping containers shall be examined for the defects listed in table III. The lot size shall be expressed in shipping containers. The sample unit shall be one shipping container fully packed. The inspection level shall be S-3 and the AQL, expressed in terms of defects per hundred units, shall be 4.0 for major defects and 10.0 for total defects.

TABLE III. Shipping container and marking defects

Category		Defect
<u>Major</u>	<u>Minor</u>	
101		Marking missing or incorrect or illegible.
102		Inadequate workmanship. <u>1/</u>
	201	More than 40 pounds of product.

1/ Inadequate workmanship is defined as, but not limited to, incomplete closure of container flaps, loose strapping, inadequate stapling, improper taping, or bulged or distorted container.

PCR-D-002B
13 August 2012
SUPERSEDING
PCR-D-002A
28 September 2007
W/CHANGE 01 14 Nov 2012

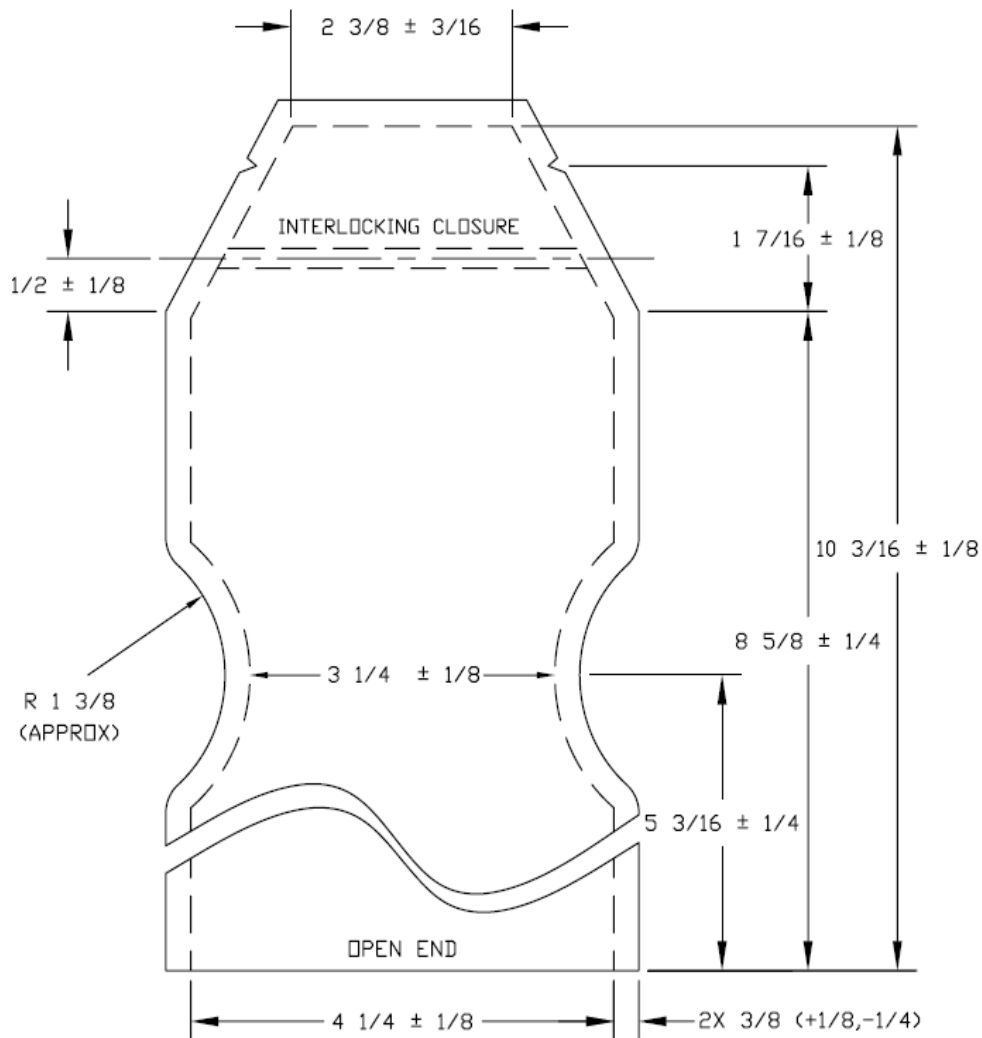

FIGURE 1. Design B Flat, Interlocking Closure Pouch
 (Not actual size)

PCR-D-002B
13 August 2012
SUPERSEDING
PCR-D-002A
28 September 2007
W/CHANGE 01 14 Nov 2012

SECTION J REFERENCE DOCUMENTS

Unless otherwise specified, the applicable version of these documents is that which is active on the date of the solicitation or contract.

U.S. STANDARDS FOR GRADES

U.S. Standards for Instant Nonfat Dry Milk

DLA Troop Support Form

FORM 3556 Marking Instructions for Boxes, Sacks, and Unit Loads of
Perishable and Semiperishable Subsistence

GOVERNMENT STANDARD

DEPARTMENT OF COMMERCE

NATIONAL INSTITUTE OF STANDARDS AND TECHNOLOGY www.nist.gov

NIST Handbook 133 Checking the Net Contents of Packaged Goods

FOOD AND DRUG ADMINISTRATION Bacteriological Analytical Manual (BAM)
<http://www.fda.gov/Food/ScienceResearch/LaboratoryMethods/BacteriologicalAnalyticalManualBAM/default.htm>

FEDERAL STANDARD

FED-STD-595 Colors Used in Government Procurement

NON-GOVERNMENTAL STANDARDS

AMERICAN SOCIETY FOR QUALITY (ASQ) www.asq.org

ANSI/ASQ Z1.4 Sampling Procedures and Tables for Inspection by
Attributes

ASTM INTERNATIONAL www.astm.org

PCR-D-002B
13 August 2012
SUPERSEDING
PCR-D-002A
28 September 2007
W/CHANGE 01 14 Nov 2012

B479	Standard Specification for Annealed Aluminum and Aluminum-Alloy Foil for Flexible Barrier, Food Contact, and Other Applications
D1974/D1974M	Standard Practice for Methods of Closing, Sealing, and Reinforcing Fiberboard Boxes
D2103	Standard Specification for Polyethylene Film and Sheeting
D5118/D5118M	Standard Practice for Fabrication of Fiberboard Shipping Boxes
F88/F88M	Standard Test Method for Seal Strength of Flexible Barrier Material

AOAC INTERNATIONAL www.aoac.org

Official Methods of Analysis (OMA) of AOAC International

AMERICAN PUBLIC HEALTH ASSOCIATION

Standard Methods for the Examination of Dairy Products; 17th edition (June 1, 2004)

ISBN-10: 0875530028

ISBN-13: 978-0875530024

PCR-D-002B
13 August 2012
SUPERSEDING
PCR-D-002A
28 September 2007
W/CHANGE 01 14 Nov 2012

For DLA Website Posting

RDNS-CFF

14 November 2012

TO: DLA-FTRE

SUBJECT: ES13-001 (DSCP-SS-13-05188); Document changes to PCR-D-002B, Dairyshake Powder, Fortified with Calcium and Vitamin D, Packaged in a Flexible Pouch, Shelf Stable; Remove 100 grams net weight packaging; Meal Cold Weather/ Food Packet, Long Range Patrol and the Unitized Group Ration™-Express™

1. Natick has initiated an Engineering Support change to remove the 100 grams net weight requirement for Dairyshake powder for use in the Meal, Cold Weather/ Food Packet, Long Range Patrol and the Unitized Group Ration™-Express™. All package types will now require a net weight of 70 grams.
2. Natick submits the following changes to the subject document for all current, pending, and future contracts until the document is formally amended or revised:
 - a. p.1, Section C-1, Packages, delete entire listing.
 - b. p. 3, Section C-2, E, delete entire subparagraph (1).
 - c. p.3, Section C-2, E, (2), delete “(2) Packages C and J.” heading and keep content of subparagraph.
 - d. p. 7, Section D-1, A, delete first and second sentences. Add new second sentence “Seventy grams of powdered product shall be filled into a preformed barrier pouch.”
 - e. p 8, Section D-2, A, Fill line: delete first sentence and “Packages C and J” from beginning of second sentence. Add “A” at beginning of second sentence.
 - f. p 11, Section E-5, A, Table I, Product defects, minor defect 203, delete “less than 3.4 ounces (95 grams) or” and delete “as applicable”.

PCR-D-002B
13 August 2012
SUPERSEDING
PCR-D-002A
28 September 2007
W/CHANGE 01 14 Nov 2012

- g. p 13, Section E-5, A, Table I, Product defects, footnote 9, delete first sentence and beginning of second sentence “For packages C and J,”.
3. Attached is Change 01 Dairyshake Powder, Fortified with Calcium and Vitamin D, Packaged in a Flexible Pouch, PCR-D-002B dated 14 November 2012, with changes highlighted.
4. The Service Representatives were contacted and their replies were:
Army: Concur; Marine Corps: Concur